

LS

totally enclosed single-phase asynchronous motors

General information



Totally enclosed, single-phase asynchronous motors, LS series, according to IEC 60034, 60038, 60072. Power 0.09 to 5.5 kW. Frame size from 56 to 132 mm*. 2, 4 and 6 poles.

Mains supply
230 V +10% -10 %, 50 Hz.

Protection
Standard version IP 55 providing a good sealing to liquid projection and to dust in an industrial environment.

Class F standard **winding**, made on automatic machines providing reproducibility and reliability.
Impregnated on automatic assembly line with a tropicalised varnish class H providing a good operation in humid environments (up to 90 % relative humidity).

Aluminium squirrel-cage **rotor** poured under pressure, providing the rigidity of the rotating component, dynamically balanced.

Possibilities

For applications that require a high starting torque and a high permanent torque: model "PR" (with relay and start condenser, plus permanent condenser) up to and including frame size 90 inclusive.

For applications that do not require a high starting inertia: model "P" (with permanent condenser).

Individual controls before expedition

- routine testing (testing without load, dielectric testing, resistance control and control of the direction of rotation).
- vibration level according to the class N and noise level in accordance with IEC 60034-9.

Finishing

Assembled with protected screws.
Painting, RAL 6000 finish (green).
Protection of the flange and shaft end against atmospheric corrosion.
Individual anti-shock packing.

Construction

Description of the aluminium standard single-phase motors

Component	Materials	Remarks
Finned housing	Aluminium alloy	- with bolt-on or cast foot, or without foot - pressure die cast for frame size ≤ 132 <ul style="list-style-type: none"> • 4 or 6 mounting holes for the foot housings • lifting rings, option in 132 and 112 - earth terminal available, optional
Stator	Insulated low carbon magnetic steel laminations Electrolytic copper	- the low carbon content guarantees long term stability of the characteristics - assembled lamination pack - semi-closed slots - insulation system class F
Rotor	Insulated low carbon magnetic steel laminations Aluminium (A5L)	- inclined slots - squirrel cage pressure die cast in aluminium (or alloy for special applications) - mounted on the shaft by heat shrinking - dynamically balanced rotor
Shaft	Steel	- for frame size < 132: <ul style="list-style-type: none"> • centre hole fitted with a screw and a shaft end washer • closed keyway
End shields	Aluminium alloy	- LS 56 - 63 - 71 front and rear - LS 80 - 90 front (B3, B14) and rear - LS 80 - 90 front in B5 (available as an optional extra for LS 80 and 90 rear) - LS 100 to 132 front and rear
Bearings and lubrication		- ball bearings 2RS set C3 - type ZZ lubricated for life - rear preloaded bearings
Labyrinth seals Lipseals	Technopolymer or steel Synthetic rubber	- front jet deflector for all flange motors (joint as an optional extra) - low passage, jet deflector or deflector for foot motor (joint as an optional extra)
Fan	Composite material	- 2 directions of rotation: straight blades
Fan cover	Composite material or steel sheet metal	- fitted, on request, with a drip cover for vertical operation, shaft end directed to the bottom
Terminal box	Aluminium alloy	- IP 55 - rotatable in 4 directions, mounted opposite position to feet - fitted with a standard 6 steel stud terminal board (brass as an optional extra) - terminal box delivered fitted with cable glands (without cable glands as an optional extra) - 1 earth terminal in all terminal boxes
Permanent condensor	Plated polypropylene film	- 400 V, class B, 25/085/21 according to EN 60252-1
Start condensor	Plated polypropylene film	- 250 V
Start relay		

LS totally enclosed single-phase asynchronous motors

Mounting positions

Foot mounted motors

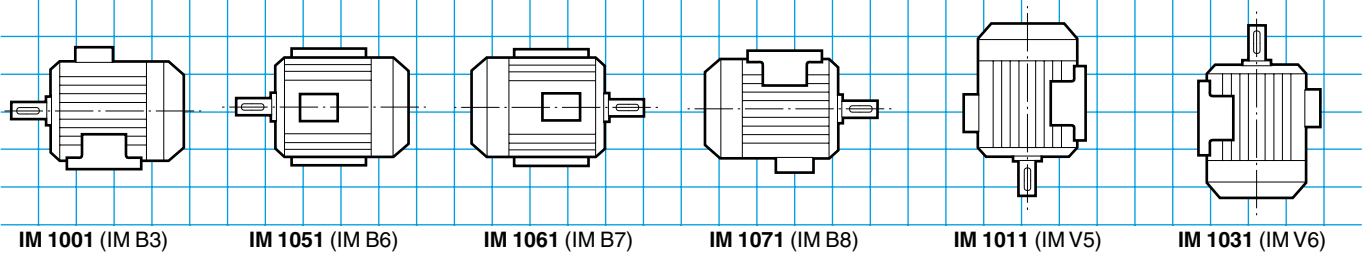

(FF) plain hole flange mounted motors

• Possible position IM 3001 (IM B5) up to 225 frame size inclusive

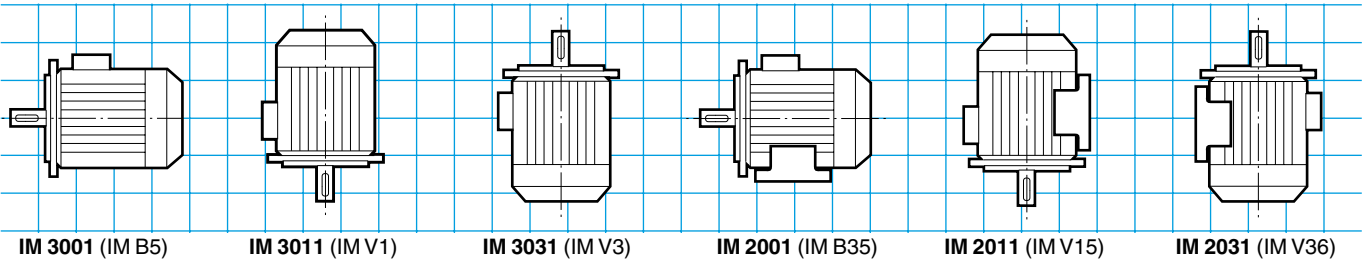

(FT) tapped hole flange mounted motors

• Possible positions up to 132 frame size inclusive

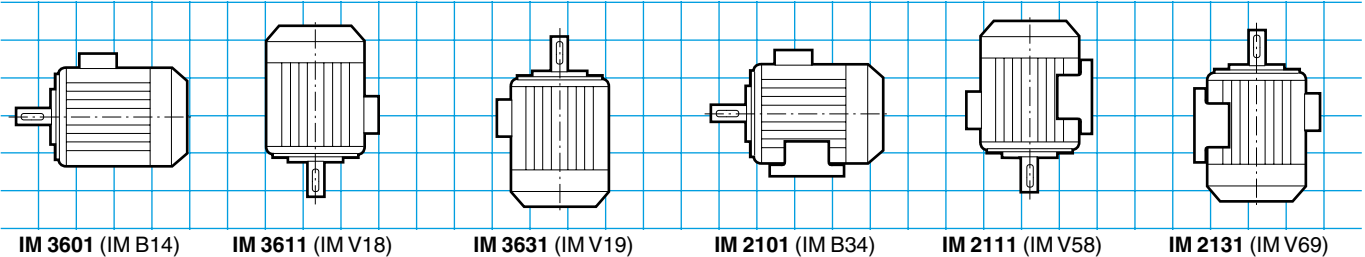

Terminal box positions in relation to the motor shaft end

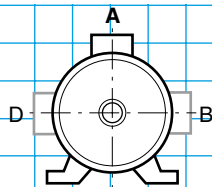

A : standard

Cable gland positions in relation to the motor shaft end

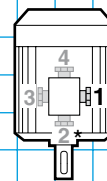

1 : standard

* Position 2 not recommended and not feasible
on plain hole flange standard motor (FF)

LS totally enclosed single-phase asynchronous motors

Possibilités d'adaptation

Leroy-Somer offers, for use with the LS totally enclosed single-phase asynchronous motors, many options which meet the needs of highly diverse applications. They are described below and in the chapters relating to gearboxes and speed variation.

For other variants or all specific adaptation, consult the technical specialists at Leroy-Somer.



The LS single-phase motors may be fitted to gearboxes

The options :

- thermal protection
- aluminium terminal box
- brass cable glands
- cable glands of different dimensions
- second shaft end
- non standard flanges

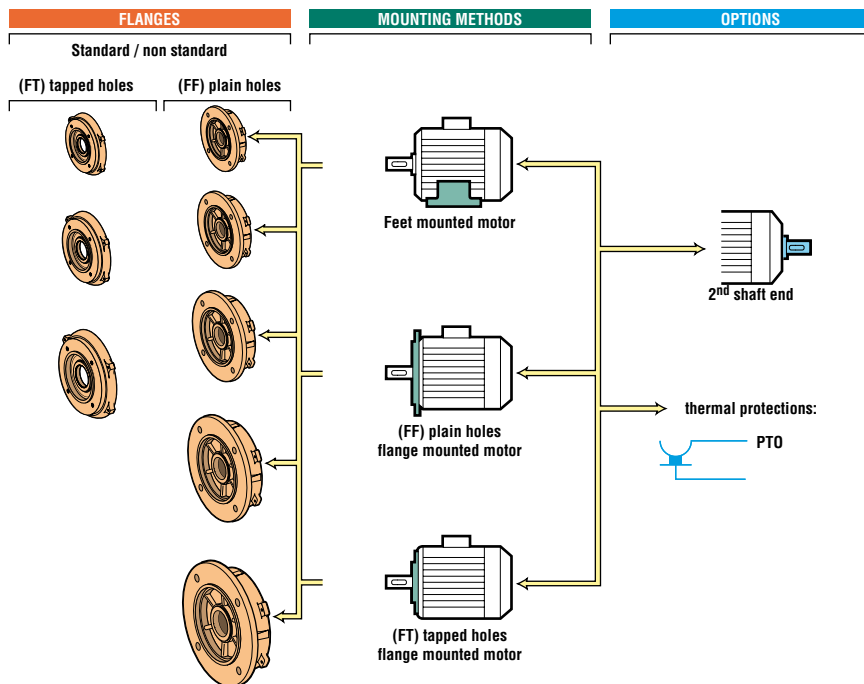

Designation / Codification

4P 1500 min-1	LS	71	P	0.37 kW	IM 1001 (IM B3)	230 V	50 Hz	IP 55
Speed polarity	Motor type	IEC 60072-1 frame size	Starting mode	Rated power	IEC 60034-7 mounting position	Power supply voltage	Power supply frequency	IEC 60034-5 protection

Codification example:

LS single-phase asynchronous motor, 1500 min-1, IM 1001 (IM B3), 0.37 kW, 230 V

Designation	Code
4P LS 71 P 0.37 kW IM 1001 (IM B3) 230 V	MA4 37 113

Codification example:

PTO thermal protection addition

Designation	Code
+ PTO	MA PT 1011

The table above is an example.

It allows the creation of the designation for the required product.

This designation corresponds to a product code.

The product codes that are present in the selection grids can be used directly. They simplify the ordering process.

The codification table is incorporated in the price list with the designations list.

LS

totally enclosed single-phase asynchronous motors

Selection

2
poles
3000 min⁻¹

With permanent condenser (P)
IP 55 - 50 Hz - Class F - 230 V

Type	Rated power at 50 Hz	Rated speed	Rated current	Power factor	Efficiency	Starting current / Rated current	Weight
	P_N kW	N_N min ⁻¹	I_N (230 V) A	$\cos \varphi$ 100 %	η 100 %	I_D / I_N	IM B3 kg
LS 56 P	0.09	2790	0.9	0.85	50	3.4	3.5
LS 63 P	0.12	2820	1	0.90	57	4	4
LS 63 P'	0.12	2820	1	0.90	57	4	4
LS 63 P	0.18	2820	1.4	0.90	62	4.5	4.5
LS 63 P'	0.18	2820	1.4	0.90	62	4.5	4.5
LS 71 P	0.25	2780	1.95	0.90	61	3.5	5.5
LS 71 P	0.37	2850	2.7	0.85	70	4.7	7
LS 71 P	0.55	2770	3.5	0.95	72	4.5	7.5
LS 80 P	0.75	2780	4.85	0.95	70	4.2	9
LS 80 P	1.1	2760	6.6	0.98	73	4.1	11
LS 90 P	1.1	2700	7.5	0.90	73	4.3	14
LS 90 P	1.5	2780	9.1	0.95	76	4.8	16.5

1. Flange or foot motor (or foot and flange) with shaft end different from the standard (D: 14 j6 - E: 30 mm).

4
poles
1500 min⁻¹

With permanent condenser (P)
IP 55 - 50 Hz - Class F - 230 V

Type	Rated power at 50 Hz	Rated speed	Rated current	Power factor	Efficiency	Starting current / Rated current	Weight
	P_N kW	N_N min ⁻¹	I_N (230 V) A	$\cos \varphi$ 100 %	η 100 %	I_D / I_N	IM B3 kg
LS 56 P	0.06	1420	0.72	0.90	39	2.7	3.5
LS 63 P	0.09	1380	0.75	0.95	55	2.4	4
LS 63 P	0.12	1410	1	0.95	50	2.8	4.5
LS 63 P'	0.12	1410	1	0.95	50	2.8	4.5
LS 71 P	0.18	1430	1.8	0.75	57	3.9	6
LS 71 P	0.25	1430	2.1	0.80	63	4.3	6.5
LS 71 P	0.37	1410	2.8	0.85	66	4	7.5
LS 80 P	0.55	1370	4.2	0.85	67	3.6	8.5
LS 80 P	0.75	1370	5.4	0.85	69	3.9	10.5
LS 90 P	1.1	1420	7	0.95	71	5	16

1. Flange or foot motor (or foot and flange) with shaft end different from the standard (D: 14 j6 - E: 30 mm).

6
poles
1000 min⁻¹

With permanent condenser (P)
IP 55 - 50 Hz - Class F - 230 V

Type	Rated power at 50 Hz	Rated speed	Rated current	Power factor	Efficiency	Starting current / Rated current	Weight
	P_N kW	N_N min ⁻¹	I_N (230 V) A	$\cos \varphi$ 100 %	η 100 %	I_D / I_N	IM B3 kg
LS 71 P	0.12	930	1.15	0.95	48	3.1	7
LS 80 P	0.37	920	3	0.98	53	2.8	10

LS totally enclosed single-phase asynchronous motors

Selection

2
poles
3000 min⁻¹

With permanent condenser (P)
IP 55 - 50 Hz - Class F - ΔT 80 K - 230 V

A

Type	Rated power at 50 Hz P_N kW	IM 1001 (IM B3)		IM 3001 (IM B5)		IM 3601 (IM B14)		IM 2001 (IM B35)		IM 2101 (IM B34)	
		Code	Qty	Code	Qty	Code	Qty	Code	Qty	Code	Qty
LS 56 P	0.09	MA2 09 101	5		-	MA2 09 105	5	MA0 00 059	5	MA0 00 079	5
LS 63 P	0.12	MA2 12 101	5		-		-	MA0 00 060	5	MA0 00 080	5
LS 63 P'	0.12	MA0 00 051	5		-		-	MA0 00 061	5	MA0 00 081	5
LS 63 P	0.18	MA0 00 052	5		-		-	MA0 00 062	5	MA0 00 082	5
LS 63 P'	0.18	MA2 18 101	5		-		-	MA0 00 063	5	MA0 00 083	5
LS 71 P	0.25	MA2 25 113	5		-		-	MA0 00 064	5	MA0 00 084	5
LS 71 P	0.37	MA2 37 113	5		-		-	MA0 00 065	5	MA0 00 085	5
LS 71 P	0.55	MA2 55 107	5	MA2 55 109	5		-	MA0 00 066	5	MA0 00 086	5
LS 80 P	0.75	MA2 75 107	5		-		-	MA0 00 067	5	MA0 00 087	5
LS 80 P	1.1	MA0 00 054	5		-		-	MA0 00 068	5	MA0 00 088	5
LS 90 P	1.1	MA2 11 207	5		-		-		-		-
LS 90 P	1.5	MA2 15 207	5		-		-		-		-

1. Flange or foot motor (or foot and flange) with shaft end different from the standard (D: 14 j6 - E: 30 mm).

4
poles
1500 min⁻¹

With permanent condenser (P)
IP 55 - 50 Hz - Class F - ΔT 80 K - 230 V

Type	Rated power at 50 Hz P_N kW	IM 1001 (IM B3)		IM 3001 (IM B5)		IM 3601 (IM B14)		IM 2001 (IM B35)		IM 2101 (IM B34)	
		Code	Qty	Code	Qty	Code	Qty	Code	Qty	Code	Qty
LS 56 P	0.06	MA4 06 101	5	MA4 06 103	5		-	MA0 00 069	5	MA0 00 089	5
LS 63 P	0.09		-		-		-		-		-
LS 63 P	0.12	MA0 00 056	5		-		-	MA0 00 070	5	MA0 00 090	5
LS 63 P'	0.12	MA4 12 113	5	MA4 12 115	5		-	MA0 00 071	5	MA0 00 091	5
LS 71 P	0.18	MA4 18 101	5		-		-	MA0 00 072	5	MA0 00 092	5
LS 71 P	0.25	MA4 25 113	5		-	MA4 25 117	5	MA0 00 073	5	MA0 00 093	5
LS 71 P	0.37	MA4 37 113	5	MA4 37 115	5	MA4 37 117	5	MA0 00 074	5	MA0 00 094	5
LS 80 P	0.55	MA4 55 107	5		-		-	MA0 00 075	5	MA0 00 095	5
LS 80 P	0.75	MA4 75 107	5	MA4 75 109	5		-	MA0 00 076	5	MA0 00 096	5
LS 90 P	1.1	MA4 11 207	5		-		-		-		-

1. Flange or foot motor (or foot and flange) with shaft end different from the standard (D: 14 j6 - E: 30 mm).

6
poles
1000 min⁻¹

With permanent condenser (P)
IP 55 - 50 Hz - Class F - ΔT 80 K - 230 V

Type	Rated power at 50 Hz P_N kW	IM 1001 (IM B3)		IM 3001 (IM B5)		IM 3601 (IM B14)		IM 2001 (IM B35)		IM 2101 (IM B34)	
		Code	Qty	Code	Qty	Code	Qty	Code	Qty	Code	Qty
LS 71 P	0.12	MA6 12 101	5		-		-	MA0 00 077	5	MA0 00 097	5
LS 80 P	0.37	MA6 37 113	5		-		-	MA0 00 078	5	MA0 00 098	5

Selection example:

Speed: 1500 min⁻¹ - 4 poles
Power: 0.25 kW
Mounting and position: IM 1001 (IM B3)
Mains supply voltage: 230 V

Designation:

4P LS 71 P 0.25 kW IM 1001 (IM B3) 230 V

Code : MA4 25 113

LS

totally enclosed single-phase asynchronous motors

Selection

2
poles
3000 min⁻¹

With voltage relay (PR)
IP 55 - 50 Hz - Class F - 230 V

Type	Rated power at 50 Hz	Rated speed	Rated current	Power factor	Efficiency	Starting current / Rated current	Weight
	P_N kW	N_N min ⁻¹	I_N (230 V) A	$\cos \varphi$ 100 %	η 100 %	I_D / I_N	IM B3 kg
LS 63 PR	0.18	2900	1.4	0.85	66	6.5	5
LS 63 PR¹	0.18	2900	1.4	0.85	66	6.5	5
LS 71 PR	0.25	2900	2	0.85	65	5.5	6
LS 71 PR	0.37	2920	2.8	0.85	68	6.6	7.5
LS 71 PR	0.55	2900	3.7	0.85	74	6.6	8
LS 80 PR	0.75	2880	4.9	0.90	74	6	9.5
LS 80 PR	1.1	2860	6.6	0.90	77	5.8	11
LS 90 PR	1.5	2860	8.6	0.98	76	6	14.5
LS 90 PR	1.8	2870	10.5	0.98	76	6.1	17

1. Flange or foot motor (or foot and flange) with shaft end different from the standard (D: 14 j6 - E: 30 mm).

4
poles
1500 min⁻¹

With voltage relay (PR)
IP 55 - 50 Hz - Class F - 230 V

Type	Rated power at 50 Hz	Rated speed	Rated current	Power factor	Efficiency	Starting current / Rated current	Weight
	P_N kW	N_N min ⁻¹	I_N (230 V) A	$\cos \varphi$ 100 %	η 100 %	I_D / I_N	IM B3 kg
LS 63 PR	0.12	1430	1.05	0.90	57	4.2	5
LS 63 PR¹	0.12	1430	1.05	0.90	57	4.2	5
LS 71 PR	0.18	1460	1.7	0.75	59	5	6
LS 71 PR	0.25	1460	2.2	0.75	66	5	6
LS 71 PR	0.37	1440	2.8	0.85	68	4.7	8
LS 80 PR	0.55	1420	4.2	0.9	65	4.3	10
LS 80 PR	0.75	1430	5.2	0.85	73	5.1	10.5
LS 90 PR	1.1	1420	6.9	0.95	71	4.9	14
LS 90 PR	1.5	1430	8.6	0.98	76	5.5	17

1. Flange or foot motor (or foot and flange) with shaft end different from the standard (D: 14 j6 - E: 30 mm).

LS totally enclosed single-phase asynchronous motors

Selection

2
poles
3000 min⁻¹

With voltage relay (PR)
IP 55 - 50 Hz - Class F - 230 V

A

Type	Rated power at 50 Hz P_N kW	IM 1001 (IM B3)		IM 3001 (IM B5)		IM 3601 (IM B14)		IM 2001 (IM B35)	
		Code	Qty	Code	Qty	Code	Qty	Code	Qty
LS 63 PR	0.18	MA0 00 027	5		-	MA0 00 108	5	MA0 00 120	5
LS 63 PR'	0.18	MA0 00 100	5		-	MA0 00 109	5	MA0 00 121	5
LS 71 PR	0.25	MA0 00 030	5		-	MA0 00 110	5	MA0 00 122	5
LS 71 PR	0.37	MAM 20 370	5		-	MAM 20 374	5	MAM 20 373	5
LS 71 PR	0.55	MAM 20 550	5		-	MAM 20 554	5	MAM 20 553	5
LS 80 PR	0.75	MAM 20 750	5		-	MAM 20 754	5	MAM 20 753	5
LS 80 PR	1.1	MAM 21 100	5		-	MAM 21 104	5	MAM 21 103	5
LS 90 PR	1.5	MAM 21 500	5	MAM 21 502	5		-		-
LS 90 PR	1.8	MAM 21 800	5		-		-		-

1. Flange or foot motor (or foot and flange) with shaft end different from the standard (D: 14 j6 - E: 30 mm).

4
poles
1500 min⁻¹

With voltage relay (PR)
IP 55 - 50 Hz - Class F - 230 V

Type	Rated power at 50 Hz P_N kW	IM 1001 (IM B3)		IM 3001 (IM B5)		IM 3601 (IM B14)		IM 2001 (IM B35)	
		Code	Qty	Code	Qty	Code	Qty	Code	Qty
LS 63 PR	0.12	MA0 00 104	5		-	MA0 00 116	5	MA0 00 128	5
LS 63 PR'	0.12	MA0 00 105	5		-	MA0 00 117	5	MA0 00 129	5
LS 71 PR	0.18	MA0 00 106	5		-	MA0 00 118	5	MA0 00 130	5
LS 71 PR	0.25	MAM 40 251	5		-	MAM 40 254	5	MAM 40 257	5
LS 71 PR	0.37	MAM 40 370	5		-	MAM 40 374	5	MAM 40 373	5
LS 80 PR	0.55	MAM 40 550	5		-	MAM 40 554	5	MAM 40 557	5
LS 80 PR	0.75	MAM 40 750	5		-	MAM 40 754	5	MAM 40 753	5
LS 90 PR	1.1	MAM 41 100	5		-		-		-
LS 90 PR	1.5	MAM 41 500	5	MAM 41 502	5		-		-

1. Flange or foot motor (or foot and flange) with shaft end different from the standard (D: 14 j6 - E: 30 mm).

Selection example:

Speed: 1500 min⁻¹ - 4 poles
Power: 1.1 kW
Mounting and position: IM 1001 (IM B3)
Mains supply voltage: 230 V

Designation :

4P LS 90 PR 1.1 kW IM 1001 (IM B3) 230 V

Code : MAM 41 100

LS

totally enclosed single-phase asynchronous motors

Options



Type	Operation position (drain holes at lowest point)			
	IM V1 IM 3011	IM V3 IM 3031	IM V5 IM 1011	
LS 56	MAV 56 025	MAV 56 026	MAV 56 023	MAV 56 035
LS 56	MAV 63 001	MAV 63 013	MAV 63 024	MAV 63 036
LS 71	MAV 71 002	MAV 71 014	MAV 71 024	MAV 71 037
LS 80	MAV 80 003	MAV 80 015	MAV 80 025	MAV 80 038
LS 90	MAV 90 004	MAV 90 016	MAV 90 026	MAV 90 039

Type	PTO Thermal protection opening (n/c)	Terminal box equipment	Ventilation cover	
		Switch	Sheet metal	Drip cover
LS 56	MAPT 1011	MAIT 1011	MATE 1011	MATP 1011
LS 56	MAPT 1011	MAIT 1012	MATE 1012	MATP 1012
LS 71	MAPT 1011	MAIT 1013	MATE 1013	MATP 1013
LS 80	MAPT 1011	MAIT 1014	MATE 1014	MATP 1014
LS 90	MAPT 1011	MAIT 1015	MATE 1015	MATP 1015

 **Use guide:**

- STEP 1 : Select the base motor required according to the selection grids of the previous pages.
- STEP 2 : Select the additional option or options wanted and add them to the base designation.

 **Codification example:**

Permanent condenser single-phase motor
0.25 kW 1500 min⁻¹ with foot IM B3, 230 V with PTO.

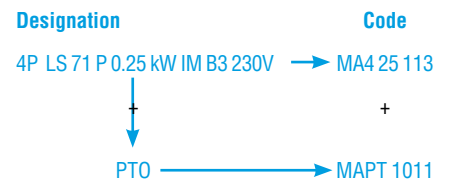

LS

totally enclosed single-phase asynchronous motors

Notes



LS totally enclosed single-phase asynchronous motors

Dimensions

Dimensions of the LS totally enclosed single-phase asynchronous motors - IP 55 Cage rotor

Dimensions in millimetres

- shaft end

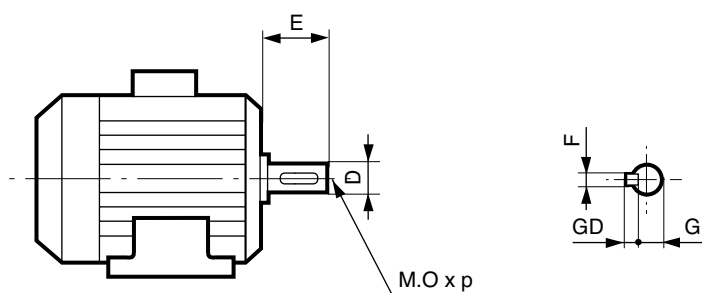

Type	Shaft end						
	F	GD	D	G	E	O	p
LS 56 P	3	3	9 j6	7.2	20	4	10
LS 63 P ¹	4	4	11 j6	8.5	23	4	10
LS 63 PR ¹	4	4	11 j6	8.5	23	4	10
LS 71 P ²	5	5	14 j6	11	30	5	12.5
LS 71 PR ²	5	5	14 j6	11	30	5	12.5
LS 80 P	6	6	19 j6	15.5	40	6	15
LS 80 PR	6	6	19 j6	15.5	40	6	15
LS 90 P	8	7	24 j6	20	50	8	20
LS 90 PR	8	7	24 j6	20	50	8	20

1. The motors LS 63 have also a shaft end $\text{O}14 \times 30$ (different from the standards).

2. Motors LS 71 P, 2P, 0.55 kW and LS 71 P, 4P, 0.37 kW: modification of the dimension LB = 193.

LS totally enclosed single-phase asynchronous motors

Dimensions

Dimensions of the LS totally enclosed single-phase asynchronous motors - IP 55 Cage rotor

Dimensions in millimetres

- foot mounted

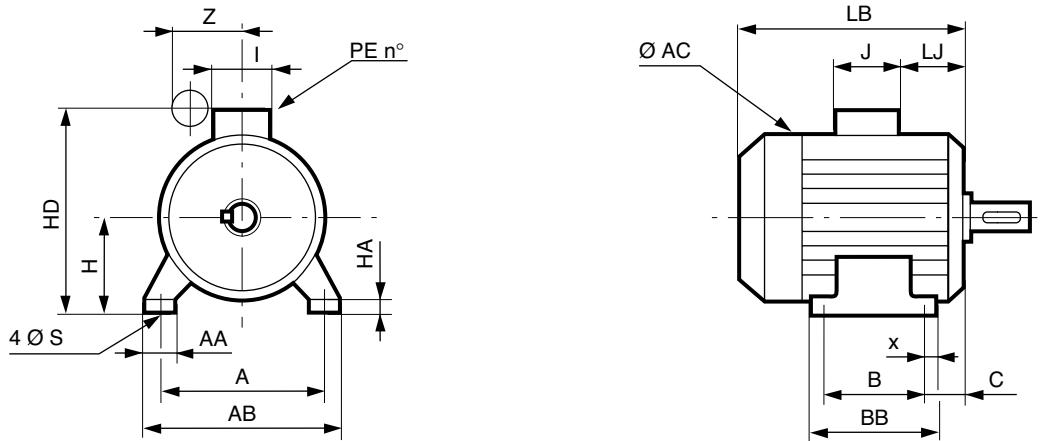

The permanent condenser is set outside the terminal box.
The starting condenser is located inside the terminal box.

Type	Main dimensions																
	A	AB	B	BB	C	AA	S	HD	Zmax.	H	LJ	HA	x	LB	AC	J	I
LS 56 P	90	104	71	87	36	24	6	148	90	56	8	7	8	156	110	86	88
LS 63 P ¹	100	115	80	97	40	24.5	7	160	90	63	18	8	8.5	172	126	86	88
LS 63 PR ¹	100	115	80	97	40	24.5	7	182	100	63	21.5	8	8.5	172	126	138	105
LS 71 P ²	112	126	90	106	45	23	7	178	90	71	18	9	8	185	140	86	88
LS 71 PR ²	112	126	90	106	45	23	7	200	100	71	21.5	9	8	185	140	138	105
LS 80 P	125	157	100	120	50	37	9	201	100	80	24.5	10	10	215	162	86	88
LS 80 PR	125	157	100	120	50	37	9	223	115	80	24.5	10	10	215	162	138	105
LS 90 P	140	172	125	162	56	30	9	221	108	90	24.5	11	27.5	245	182	86	88
LS 90 PR	140	172	125	162	56	30	9	243	115	90	24.5	11	27.5	245	182	138	105

1. The motors LS 63 have also a shaft end Ø14 x 30 (different from the standards).

2. Motors LS 71 P, 2P, 0.55 kW and LS 71 P, 4P, 0.37 kW: modification of the dimension LB = 193.

LS totally enclosed single-phase asynchronous motors

Dimensions

Dimensions of the LS totally enclosed single-phase asynchronous motors - IP 55 Cage rotor

Dimensions in millimetres

- (FF) plain hole foot and flange mounted

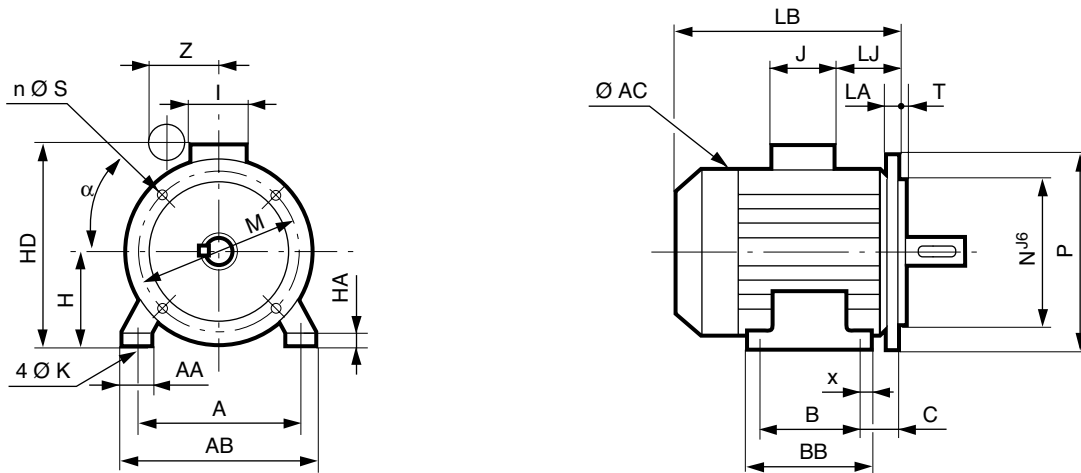

The permanent condenser is set outside the terminal box.
The starting condenser is located inside the terminal box.

Type	Main dimensions																	
	A	AA	AB	C	B	BB	H	HA	x	HD	K	HJ	Z max.	LJ	LB	AC	J	I
LS 56 P	90	24	104	36	71	87	56	7	8	148	6	92	90	8	156	110	86	88
LS 63 P ¹	100	24.5	115	40	80	97	63	8	8.5	160	7	97	90	18	172	126	86	88
LS 63 PR ¹	100	24.5	115	40	80	97	63	8	8.5	182	7	119	100	21.5	172	126	138	105
LS 71 P ²	112	23	126	45	90	106	71	9	8	178	7	107	90	18	185	140	86	88
LS 71 PR ²	112	23	126	45	90	106	71	9	8	200	7	129	100	21.5	185	140	138	105
LS 80 P	125	37	157	50	100	120	80	10	10	201	9	121	100	24.5	215	162	86	88
LS 80 PR	125	37	157	50	100	120	80	10	10	223	9	143	115	24.5	215	162	138	105
LS 90 P	140	30	172	56	125	162	90	11	27.5	221	9	131	108	24.5	265	182	86	88
LS 90 PR	140	30	172	56	125	162	90	11	27.5	243	9	153	115	24.5	265	182	138	105

1. The motors LS 63 have also a shaft end Ø14 x 30 (different from the standards).

2. Motors LS 71 P, 2P, 0.55 kW and LS 71 P, 4P, 0.37 kW : modification of the dimension LB = 193.

Dimensions of the shaft end identical to those of those of the foot mounted motors (page A1.10).

LS totally enclosed single-phase asynchronous motors

Dimensions

Dimensions of the LS totally enclosed single-phase asynchronous motors - IP 55 Cage rotor

Dimensions in millimetres

- (FF) plain hole flange mounted

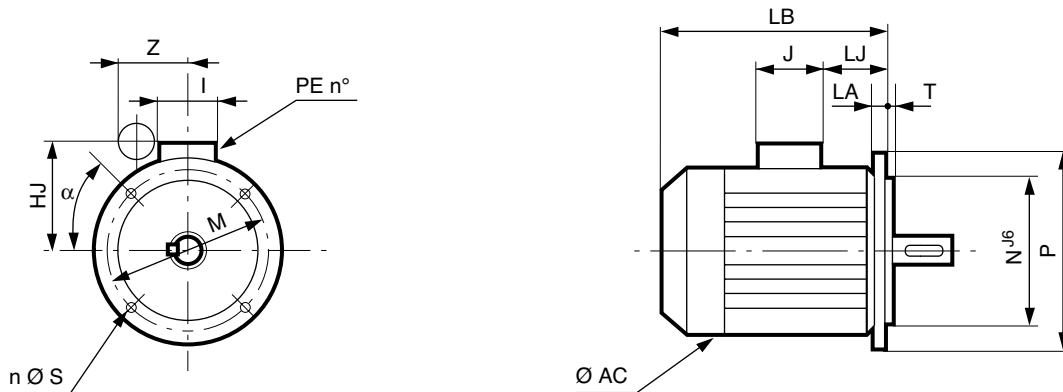

Type	Symb.	Flange dimensions						
		M	N	P	LA	α	T	S
LS 56 P	FF100	100	80	120	8	45°	3	7
LS 63 P ¹	FF115	115	95	140	10	45°	3	9
LS 63 PR ¹	FF115	115	95	140	10	45°	3	9
LS 71 P ²	FF130	130	110	160	8	45°	3.5	9
LS 71 PR ²	FF130	130	110	160	8	45°	3.5	9
LS 80 P	FF165	165	130	200	10	45°	3.5	11
LS 80 PR	FF165	165	130	200	10	45°	3.5	11
LS 90 P	FF165	165	130	200	10	45°	3.5	11
LS 90 PR	FF165	165	130	200	10	45°	3.5	11

1. The motors LS 63 have also a shaft end $\varnothing 14 \times 30$ (different from the standards).

2. Motors LS 71 P, 2P, 0.55 kW and LS 71 P, 4P, 0.37 kW: modification of the dimension $LB = 193$.

LS totally enclosed single-phase asynchronous motors

Dimensions

Dimensions of the LS totally enclosed single-phase asynchronous motors - IP 55 Cage rotor

Dimensions in millimetres

- (FT) foot and tapped hole flange mounted

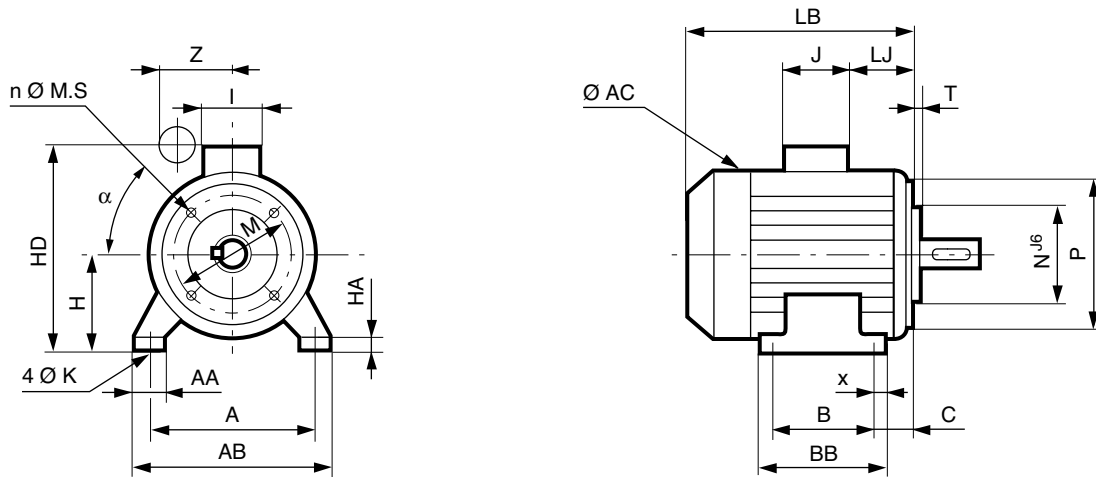

The permanent condenser is set outside the terminal box.
The starting condenser is located inside the terminal box.

Type	Main dimensions																
	A	AA	AB	B	BB	H	HA	x	HD	K	HJ	Z max.	LJ	LB	AC	J	I
LS 56 P	90	24	104	71	87	56	7	8	148	6	92	90	8	156	110	86	88
LS 63 P¹	100	24.5	115	80	97	63	8	8.5	160	7	97	90	18	172	126	86	88
LS 63 PR¹	100	24.5	115	80	97	63	8	8.5	182	7	119	100	21.5	172	126	138	105
LS 71 P²	112	23	126	90	106	71	9	8	178	7	107	90	18	185	140	86	88
LS 71 PR²	112	23	126	90	106	71	9	8	200	7	129	100	21.5	185	140	138	105
LS 80 P	125	37	157	100	120	80	10	10	201	9	121	100	24.5	215	162	86	88
LS 80 PR	125	37	157	100	120	80	10	10	223	9	143	115	24.5	215	162	138	105
LS 90 P	140	30	172	125	162	90	11	27.5	221	9	131	108	24.5	245	182	86	88
LS 90 PR	140	30	172	125	162	90	11	27.5	243	9	153	115	24.5	245	182	138	105

1. The motors LS 63 have also a shaft end $\varnothing 14 \times 30$ (different from the standards).

2. Motors LS 71 P, 2P, 0.55 kW and LS 71 P, 4P, 0.37 kW: modification of the dimension LB = 193.

Dimensions of the shaft end identical to those of the foot mounted motors (page A1.10).

LS totally enclosed single-phase asynchronous motors

Dimensions

Dimensions of the LS totally enclosed single-phase asynchronous motors - IP 55 Cage rotor

Dimensions in millimetres

- (FF) tapped hole flange mounted

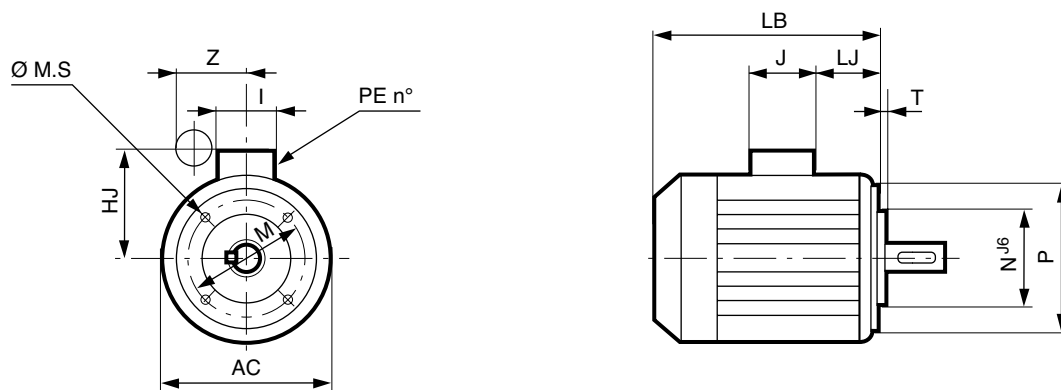

The permanent condenser is set outside the terminal box.
The starting condenser is located inside the terminal box.

Type	Symb.	Flange dimensions						
		M	N	P	LA	α	T	S
LS 56 P	FT65	65	50	80	8	45°	2.5	5
LS 63 P ¹	FT75	75	60	90	10	45°	2.5	5
LS 63 PR ¹	FT75	75	60	90	10	45°	2.5	5
LS 71 P ²	FT85	85	70	105	8	45°	2.5	6
LS 71 PR ²	FT85	85	70	105	8	45°	2.5	6
LS 80 P	FT100	100	80	120	10	45°	3	6
LS 80 PR	FT100	100	80	120	10	45°	3	6
LS 90 P	FT115	115	95	140	10	45°	3	8
LS 90 PR	FT115	115	95	140	10	45°	3	8

1. The motors LS 63 have also a shaft end $\varnothing 14 \times 30$ (different from the standards).

2. Motors LS 71 P, 2P, 0.55 kW and LS 71 P, 4P, 0.37 kW: modification of the dimension LB = 193.

