



**EMERSON**<sup>™</sup>  
Industrial Automation



4122 en - 2011.02 / f

**LERROY<sup>®</sup>  
SOMER**

Permanent Magnet Solutions  
**Dyneo<sup>®</sup>**

**LSRPM - PLSRPM**

**Synchronous motors with permanent magnets - 0.75 to 400 kW**

Technical catalogue



# Permanent magnet synchronous motors LSRPM - PLSRPM

## Contents

	PAGE		PAGE
<b>GENERAL - EFFICIENCIES .....</b>	<b>5</b>	<b>D - DIMENSIONS.....</b>	<b>39</b>
<b>SELECTION METHOD.....</b>	<b>6</b>	D1 - Shaft extensions	40
<b>A - PERFORMANCE .....</b>	<b>7</b>	D2 - Foot mounted IM B3 (IM 1001)	41
A1 - 5500 range, 0 to 5500 min <sup>-1</sup>	8	D3 - Foot and flange mounted IM B35 (IM 2001)	42
A2 - 4500 range, 0 to 4500 min <sup>-1</sup>	9	D4 - Flange mounted IM B5 (IM 3001)	43
A3 - 3600 range, 0 to 3600 min <sup>-1</sup>	10-11	D5 - Foot and face mounted IM B34 (IM 2101)	44
A4 - 3000 range, 0 to 3000 min <sup>-1</sup>	12-13	D6 - Face mounted IM B14 (IM 3601)	45
A5 - 2400 range, 0 to 2400 min <sup>-1</sup>	14-15	D7 - Motor with options	46
A6 - 1800 range, 0 to 1800 min <sup>-1</sup>	16-17	<b>E - CONSTRUCTION .....</b>	<b>47</b>
A7 - 1500 range, 0 to 1500 min <sup>-1</sup>	18-19	E1 - Definition of «Index of Protection» (IP/IK)	48
A8 - 900 range, 0 to 900 min <sup>-1</sup>	20-21	E2 - Components	49
A9 - 750 range, 0 to 750 min <sup>-1</sup>	22-23	E3 - External finish	50
A10 - 375 range, 0 to 375 min <sup>-1</sup>	24	E4 - Mounting arrangements	51
<b>B - EQUIPMENT AND OPTIONS .....</b>	<b>25</b>	E5 - Bearings and lubrication	52
B1 - Position sensor	26-27	E6 - Connection	53
B2 - Forced ventilation	28	E7 - Machine vibration level	54-55
B3 - Reinforced insulation	29	<b>F - GENERAL INFORMATION .....</b>	<b>57</b>
B4 - Cable glands	30	F1 - Quality commitment	58
B5 - Thermal protection	31	F2 - Standards and approvals	59 to 61
<b>C - ELECTRICAL CHARACTERISTICS .....</b>	<b>33</b>	F3 - Designation	62
C1 - Characteristic data	34 to 38		

# Permanent magnet synchronous motors LSRPM - PLSRPM

## Index

	PAGE		PAGE
Absolute encoder.....	27	Mechanical speeds.....	55
AFNOR/UTE.....	59	Motor efficiencies.....	5-7 to 24
		Motor torques.....	6 to 24
<b>Balancing</b> .....	54	Mounting arrangements.....	51
Bearings.....	49-52	Mountings.....	51
		<b>NEMA</b> .....	59
<b>Cable gland</b> .....	30-53	Operating positions.....	51
Connection.....	27-53	Options.....	25 to 31-46
Connection diagrams.....	28-53		
Construction.....	49	<b>Paint systems</b> .....	50
		Performance on drives.....	6 to 24
<b>Description</b> .....	49	Protection indices.....	48
Designation.....	62		
Dimensions.....	39 to 45	<b>Quality</b> .....	58
Dimensions with options.....	46		
DIN/VDE.....	59	<b>Reinforced insulation</b> .....	29
		Rotor.....	49
<b>Electrical characteristics</b> .....	33 to 38		
End shields.....	49	<b>Selection</b> .....	6 to 24
External finish.....	50	Sensor.....	26-27
		Shaft.....	49
<b>Fan cover</b> .....	49	STANDARDS.....	59 to 61
Forced ventilation.....	28	Stator.....	49
<b>Grease</b> .....	52	<b>Terminal block with terminals</b> .....	53
		Terminal box.....	49-53
<b>Housing with cooling fins</b> .....	49	Thermal protection.....	31
		Torque and efficiency characteristics.....	6 to 24
<b>Identification</b> .....	62		
IEC.....	59	<b>UL/CSA</b> .....	58
Incremental encoder.....	27		
ISO 9001.....	58	<b>Vibration</b> .....	54-55
		Vibration levels.....	54
<b>JIS</b> .....	59		
<b>Labyrinth seal</b> .....	49		
Lipseals.....	49		
Lubrication of bearings.....	52		

# Permanent magnet synchronous motors LSRPM - PLSRPM General - Efficiencies

LEROY-SOMER permanent magnet synchronous motors have efficiencies that are higher than those of induction motors and more stable over the entire selected speed range (see graph below).

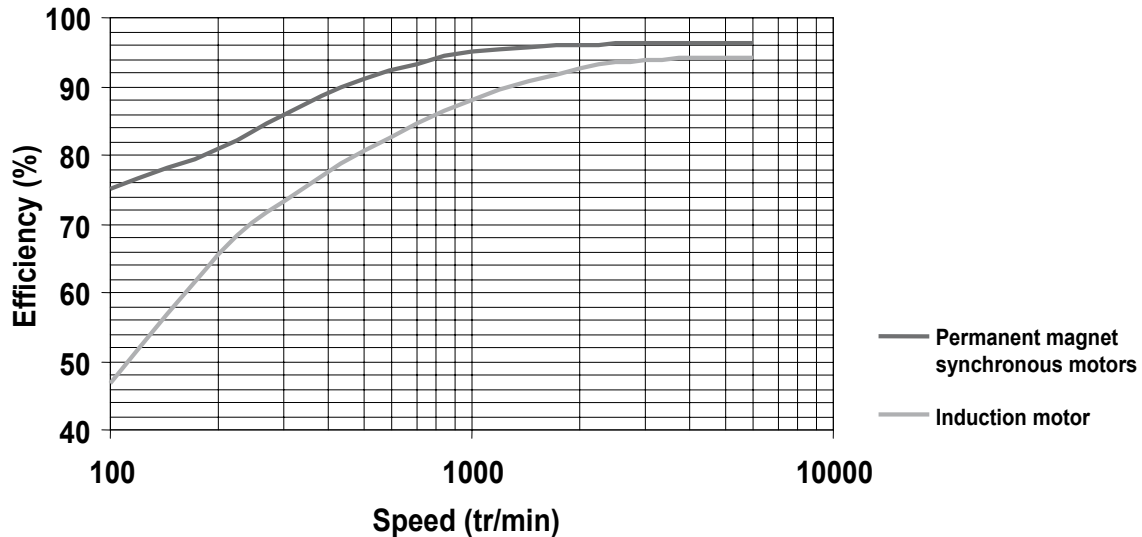

Efficiencies of synchronous motors and induction motors as a function of speed

## Efficiencies of synchronous motors and induction motors supplied by inverters :

### Efficiency of permanent magnet synchronous motors

Apart from a few exceptions, synchronous motors cannot operate correctly on a traditional sinusoidal mains supply. They are practically always supplied via a variable speed drive (VSD). This catalogue gives the efficiencies motors supplied via LEROY-SOMER VSDs'.

### Efficiency of induction motors supplied via drives :

As a general rule, the efficiencies of induction motors given in the catalogues are values measured on a sinusoidal mains supply at the rated power and speed.

The voltage and current waveforms created by the drive are not sinusoidal. Supplying via a drive therefore results in additional losses in the motor. According to specifications 60034-17, these are estimated at 20% of the total losses. These losses have a direct impact on the declared efficiency of the motor.

In variable speed mode, this efficiency should therefore be corrected in accordance with the formula below.

$$\eta_2 = 1 - (1 - \eta_1) \times 1.2$$

$\eta_2$  = efficiency of induction motor obtained on a drive

$\eta_1$  = efficiency of induction motor supplied from the mains

**Example:** 200 kW application at 3000 min<sup>-1</sup>

$\eta_1$  : Efficiency of the 200 kW, 2-pole induction motor on 50 Hz mains supply = 96 %

$\eta_2$  : Estimated efficiency of the same induction motor supplied via a drive at 50 Hz

$$\eta_2 = 1 - (1 - 0.96) \times 1.2 = 0.952 \text{ i.e. } 95.2 \%$$

**Motor efficiency = 97.3 %**

# Permanent magnet synchronous motors LSRPM - PLSRPM Selection method

## EXAMPLE

A machine requires a torque of 1050 N.m over a speed range of 300 to 2300 min<sup>-1</sup> in continuous duty..

### Choice of motor

#### 1) Selecting the range according to the speed range

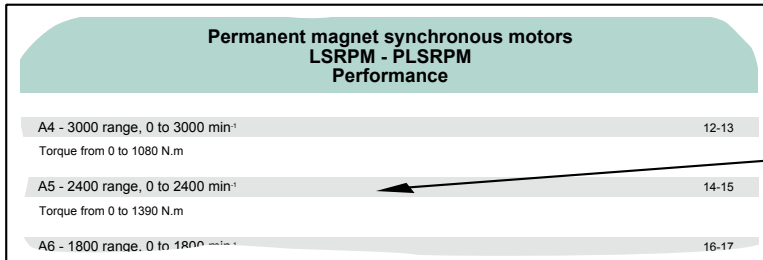

Example: Selection of the 2400 range for operation over a speed range of 300 to 2400 min<sup>-1</sup>

#### 2) Selecting the torque range

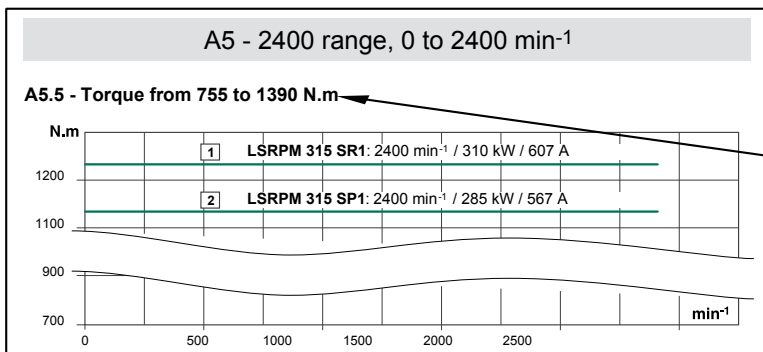

Example : Selection of the torque range 755 to 1390 N.m for a torque requirement of 1050 N.m

#### 3) Selecting the motor: choose the curve that has a torque immediately higher than the application requirements.

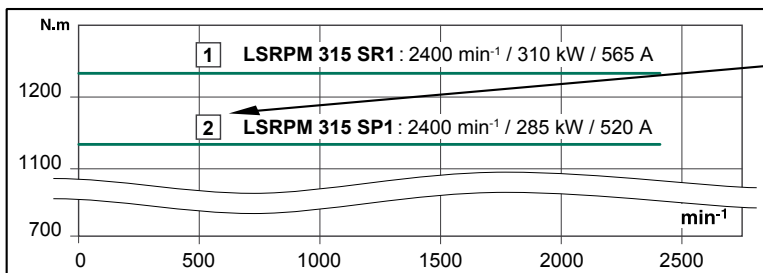

Example : Selection of curve [2] for an application requirement of 1050 N.m

**2** LSRPM 315 SP1 : 2400 min<sup>-1</sup> / 285 kW / 520 A

↓ Motor type      ↓ Rated speed      ↓ Rated power      ↓ Rated current

#### 4) Reading the efficiency: the graph shows the curves of efficiency as a function of speed.

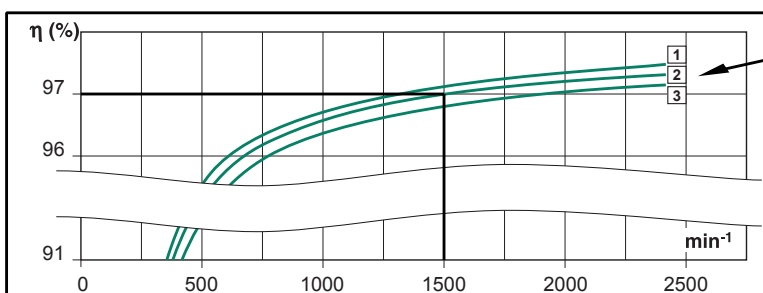

Example : Curve no. 2  
Efficiency of the selected motor at 1500 min<sup>-1</sup> = 97%

#### 5) Other characteristics :

- electrical, pages 34 to 38,
- dimensional, pages 40 to 46.

# Permanent magnet synchronous motors

## LSRPM - PLSRPM

### Performance

	PAGE
A1 - 5500 range, 0 to 5500 min <sup>-1</sup>	8
Torque from 0 to 240 N.m	
A2 - 4500 range, 0 to 4500 min <sup>-1</sup>	9
Torque from 0 to 360 N.m	
A3 - 3600 range, 0 to 3600 min <sup>-1</sup>	10-11
Torque from 0 to 1035 N.m	
A4 - 3000 range, 0 to 3000 min <sup>-1</sup>	12-13
Torque from 0 to 1080 N.m	
A5 - 2400 range, 0 to 2400 min <sup>-1</sup>	14-15
Torque from 0 to 1390 N.m	
A6 - 1800 range, 0 to 1800 min <sup>-1</sup>	16-17
Torque from 0 to 1220 N.m	
A7 - 1500 range, 0 to 1500 min <sup>-1</sup>	18-19
Torque from 0 to 1400 N.m	
A8 - 900 range, 0 to 900 min <sup>-1</sup>	20-21
Torque from 0 to 1380 N.m	
A9 - 750 range, 0 to 750 min <sup>-1</sup>	22-23
Torque from 0 to 1400 N.m	
A10 - 375 range, 0 to 375 min <sup>-1</sup>	24
Torque from 0 to 130 N.m	

The performances given are those of motors used in conjunction with LEROY-SOMER drives.  
The values and tolerances conform to IEC 60034-1.

# Permanent magnet synchronous motors LSRPM - PLSRPM Performance

## A1 - 5500 range, 0 to 5500 min<sup>-1</sup>

### A1.1 - Torque from 0 to 24 N.m

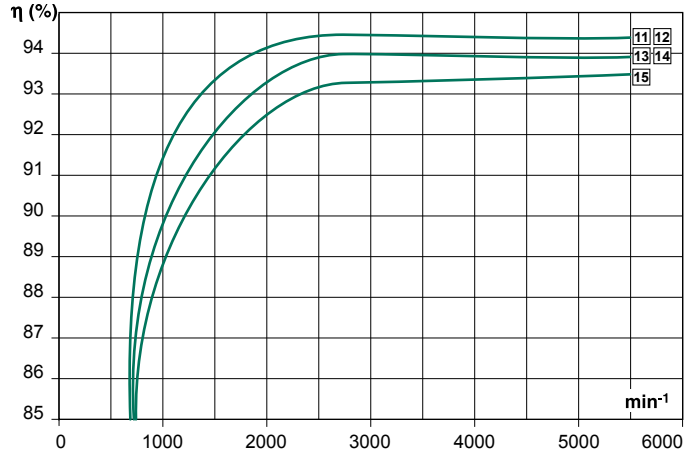
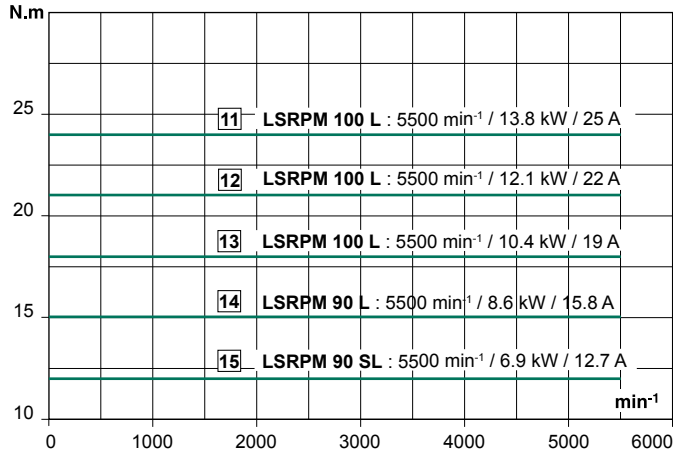

### A1.2 - Torque from 24 to 90 N.m

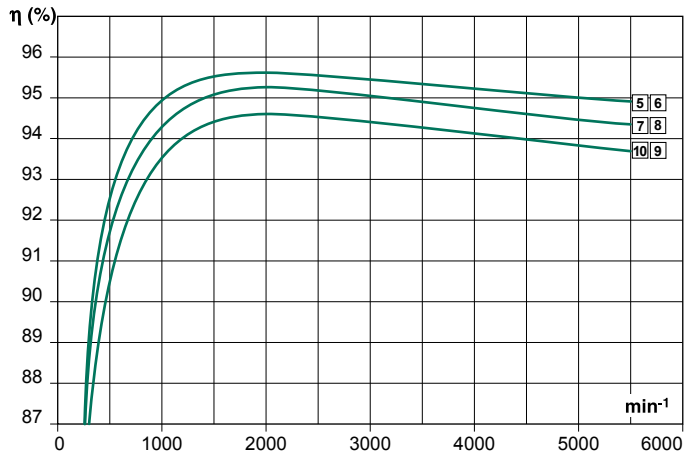
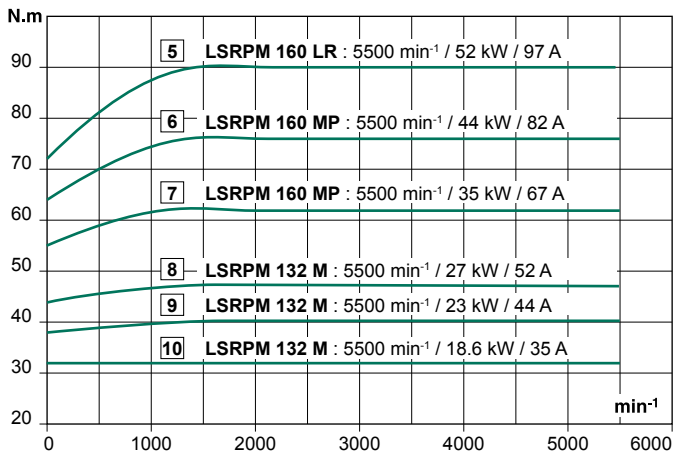

### A1.3 - Torque from 90 to 240 N.m

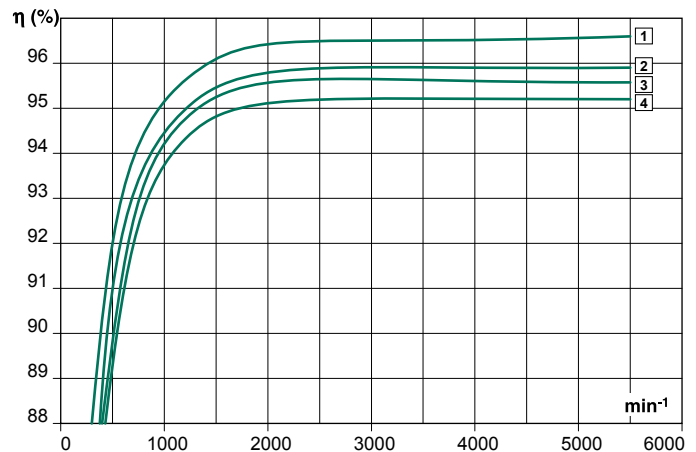
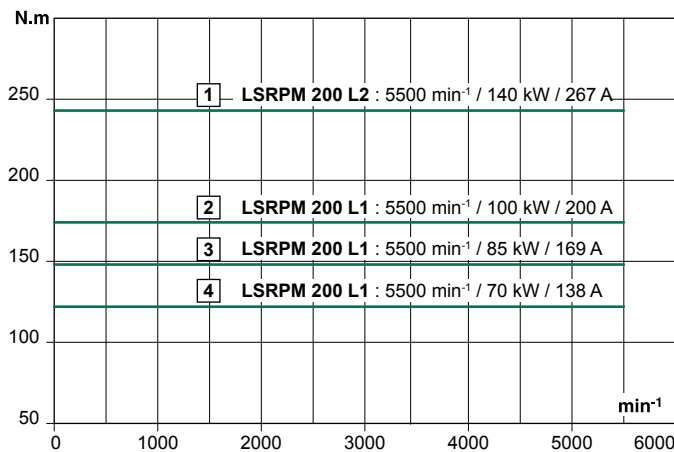

For operation at very low speeds, see the equipment and options section, pages 26, 27 and 28.

# Permanent magnet synchronous motors

## LSRPM - PLSRPM

### Performance

## A2 - 4500 range, 0 to 4500 min<sup>-1</sup>

### A2.1 - Torque from 0 to 29 N.m

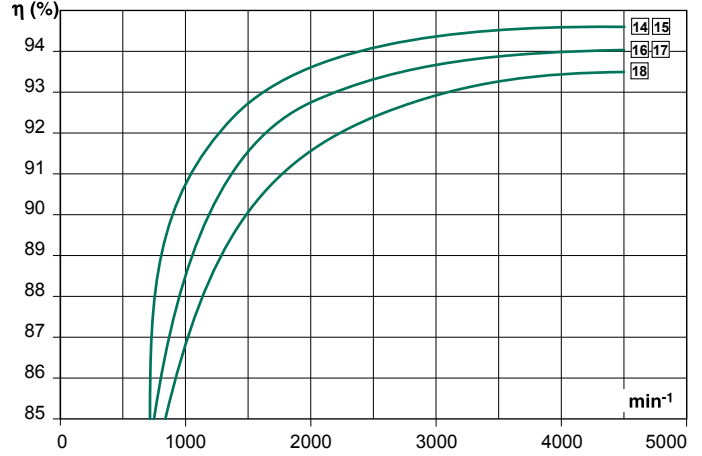
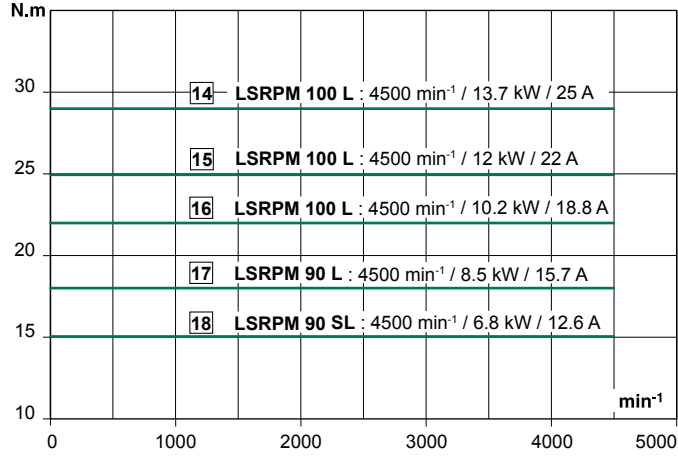

### A2.2 - Torque from 29 to 110 N.m

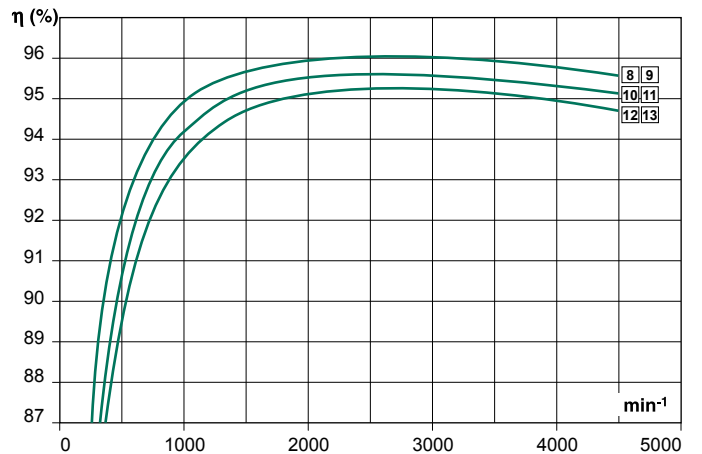
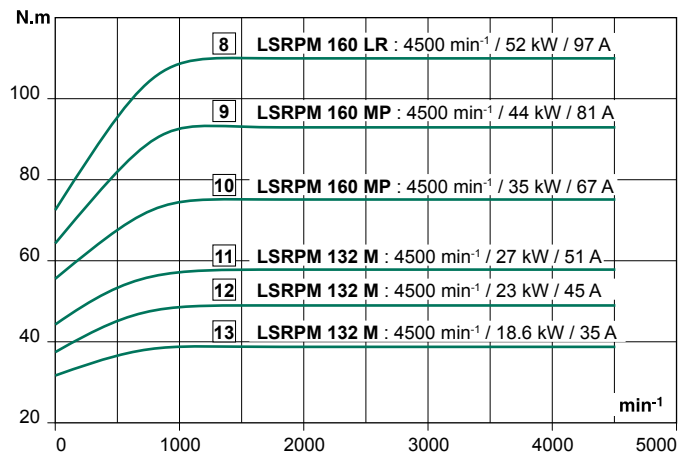

### A2.3 - Torque from 110 to 360 N.m

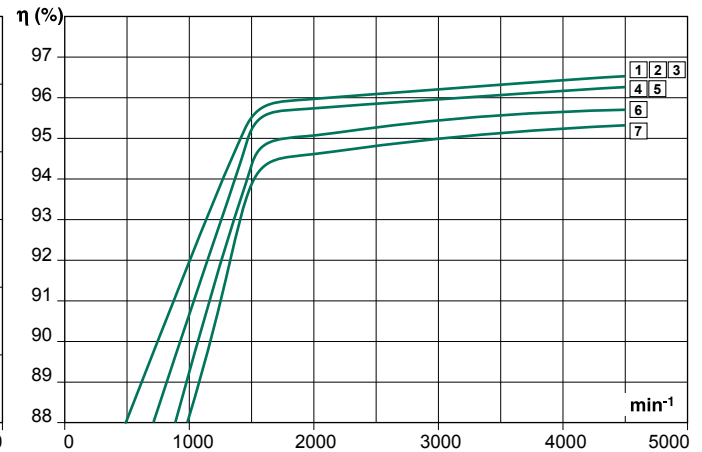
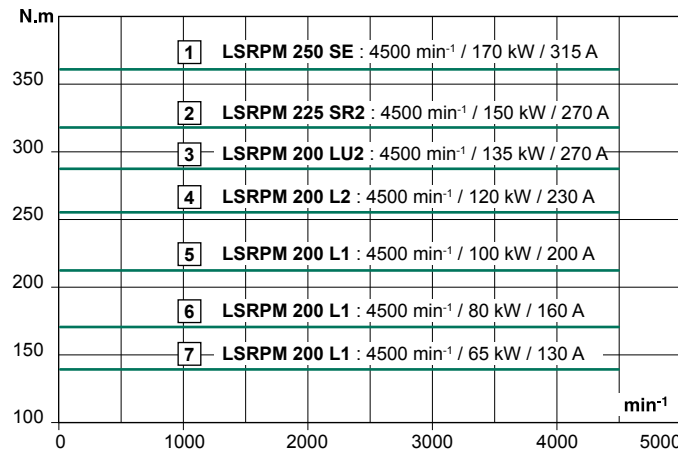

For operation at very low speeds, see the equipment and options section, pages 26, 27 and 28.

# Permanent magnet synchronous motors

## LSRPM - PLSRPM

### Performance

## A3 - 3600 range, 0 to 3600 min<sup>-1</sup>

### A3.1 - Torque from 0 to 34 N.m

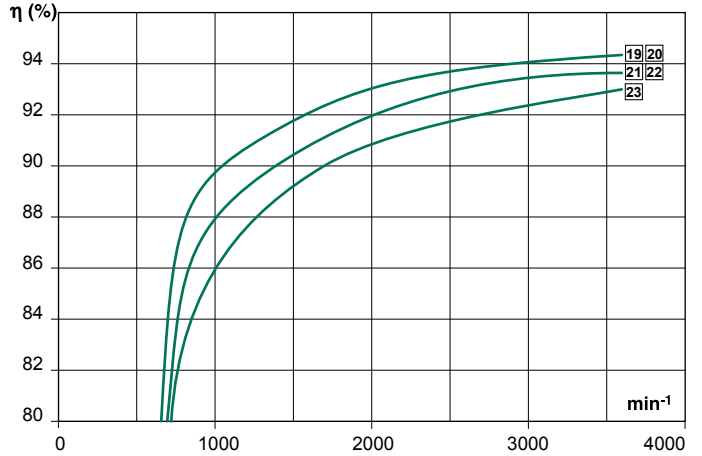
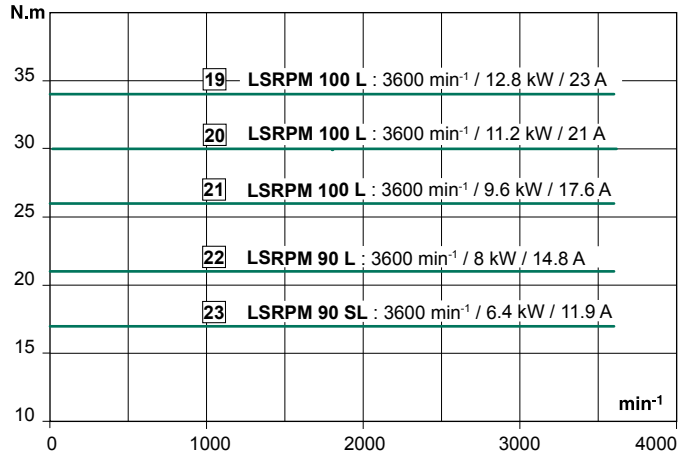

### A3.2 - Torque from 34 to 130 N.m

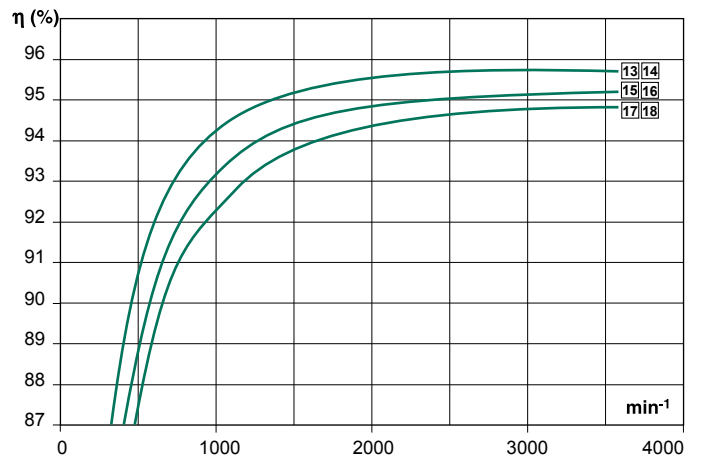
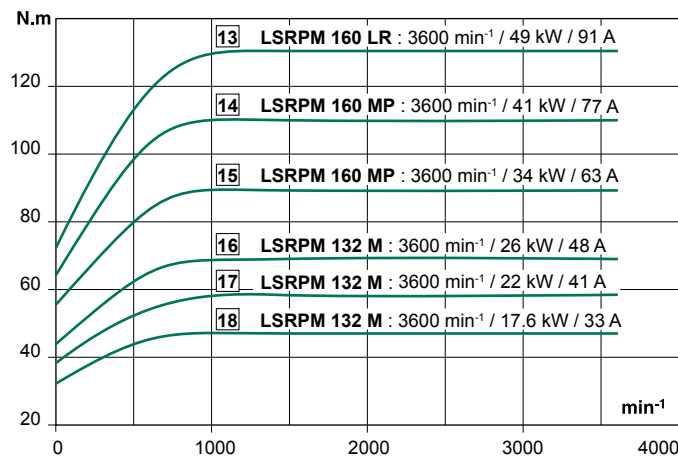

### A3.3 - Torque from 130 to 305 N.m

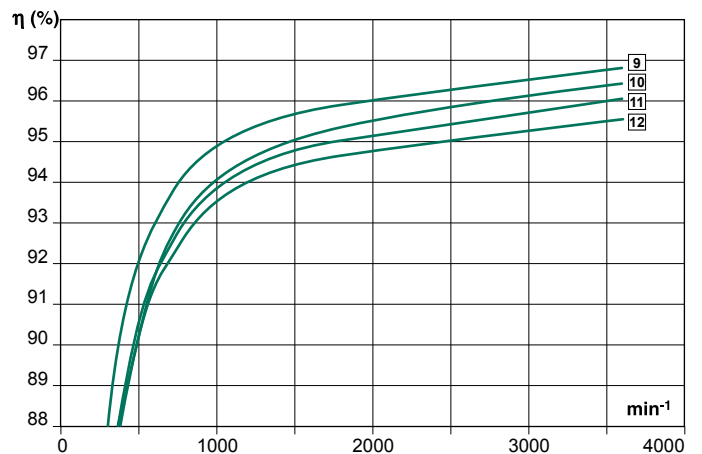
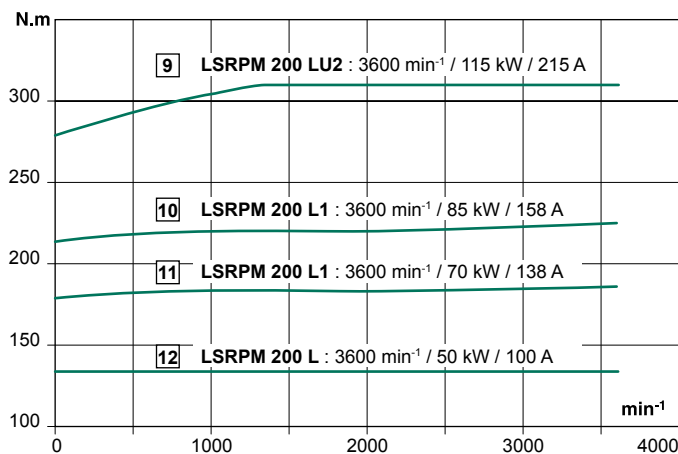

For operation at very low speeds, see the equipment and options section, pages 26, 27 and 28.

# Permanent magnet synchronous motors LSRPM - PLSRPM Performance

A3 - 3600 range, 0 to 3600 min<sup>-1</sup>

## A3.4 - Torque from 305 to 715 N.m

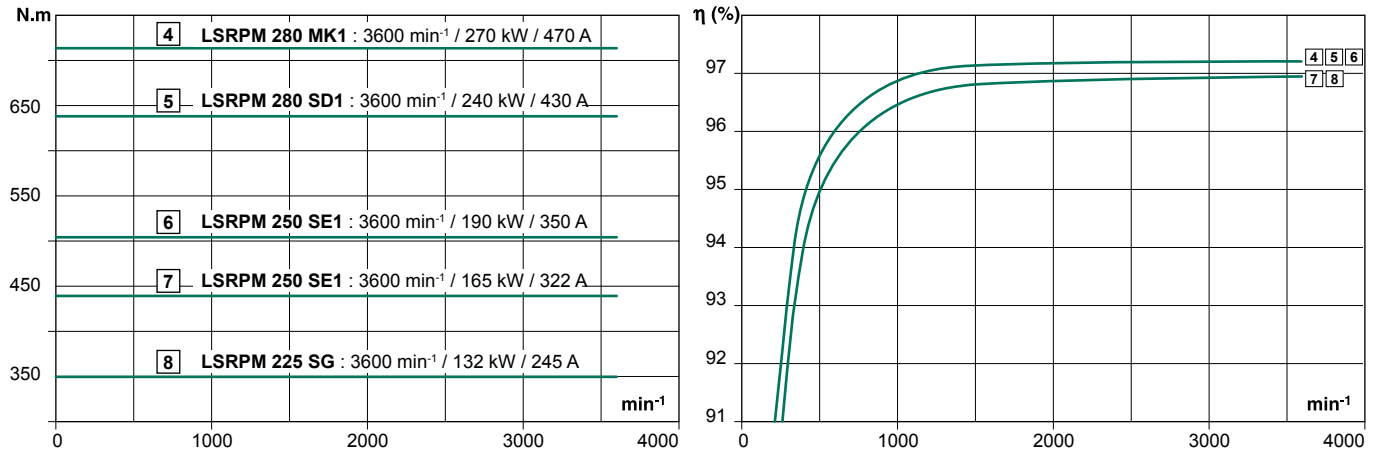

## A3.5 - Torque from 715 to 1035 N.m

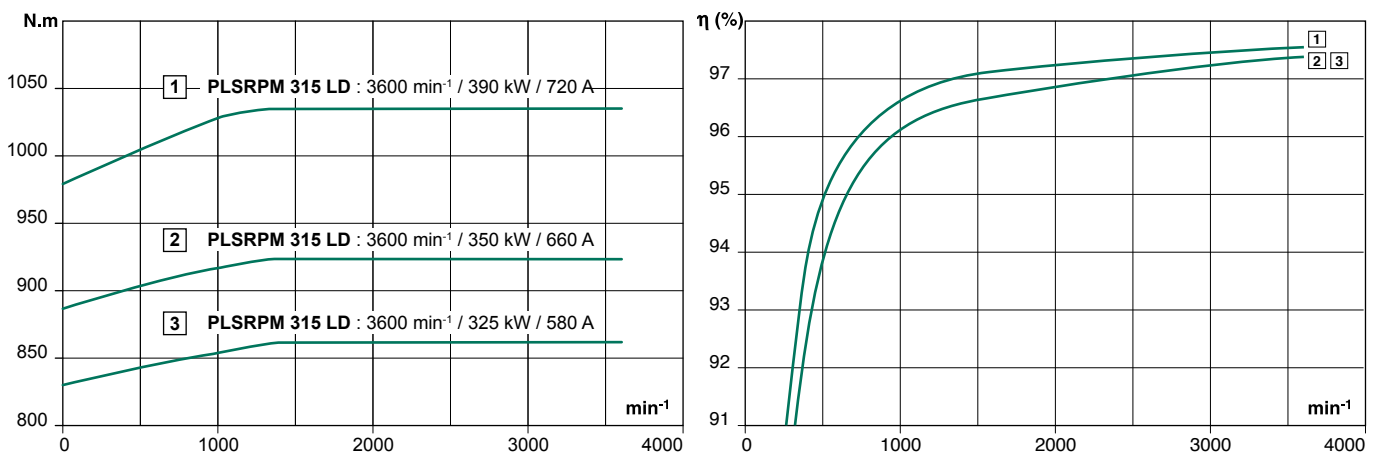

For operation at very low speeds, see the equipment and options section, pages 26, 27 and 28.

# Permanent magnet synchronous motors LSRPM - PLSRPM Performance

## A4 - 3000 range, 0 to 3000 min<sup>-1</sup>

### A4.1 - Torque from 0 to 37 N.m

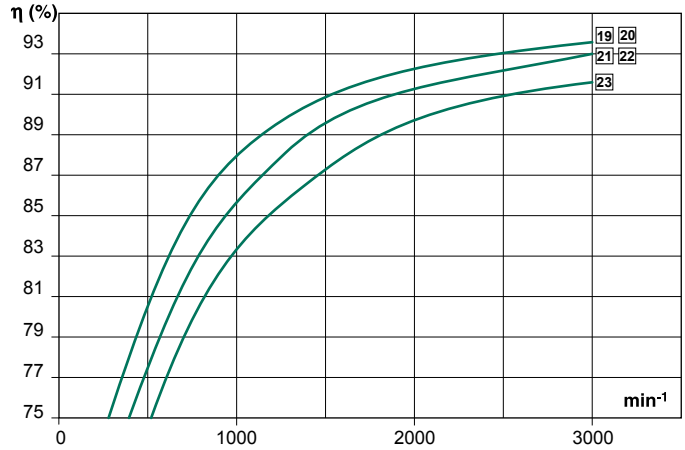
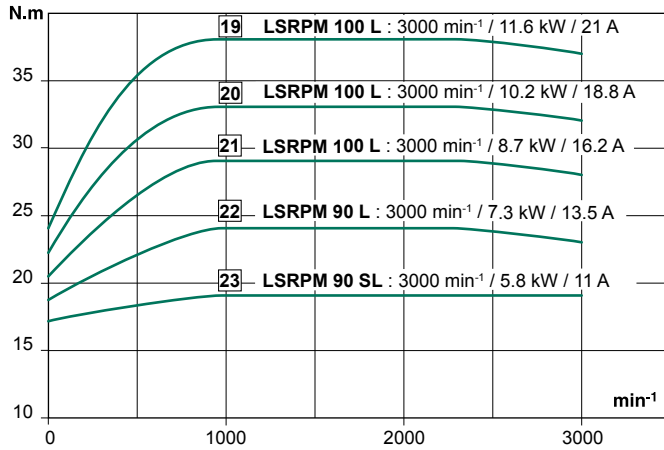

### A4.2 - Torque from 37 to 140 N.m

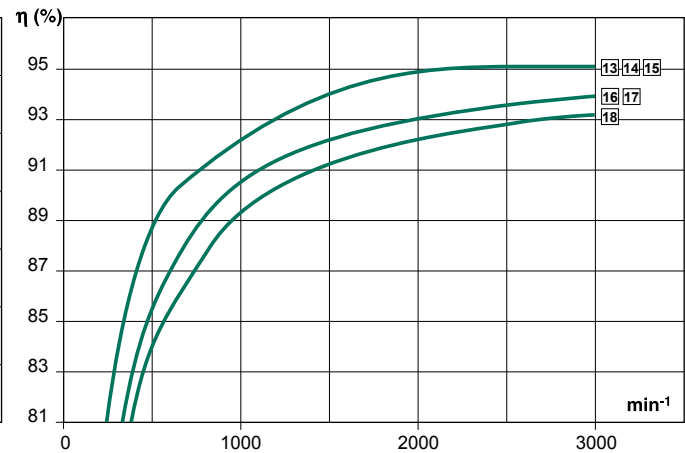

### A4.3 - Torque from 140 to 350 N.m

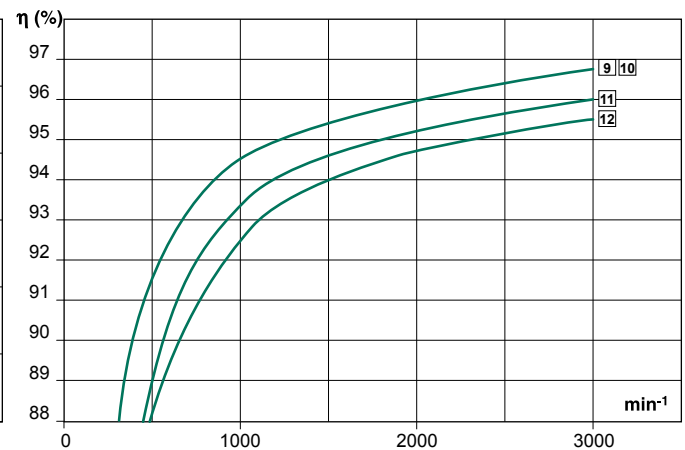
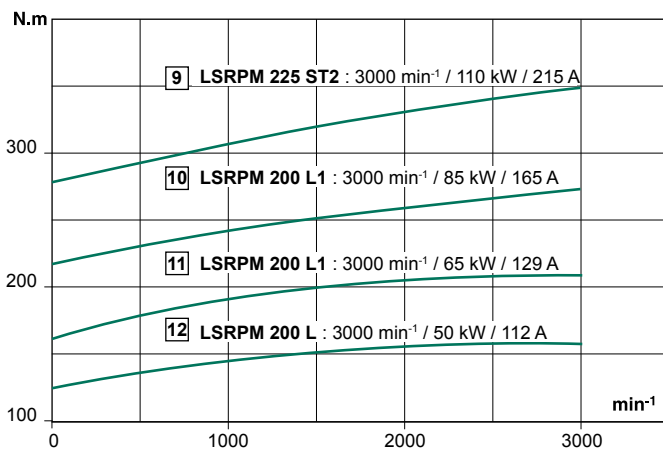

For operation at very low speeds, see the equipment and options section, pages 26, 27 and 28.

# Permanent magnet synchronous motors LSRPM - PLSRPM Performance

## A4 - 3000 range, 0 to 3000 min<sup>-1</sup>

### A4.4 - Torque from 350 to 700 N.m

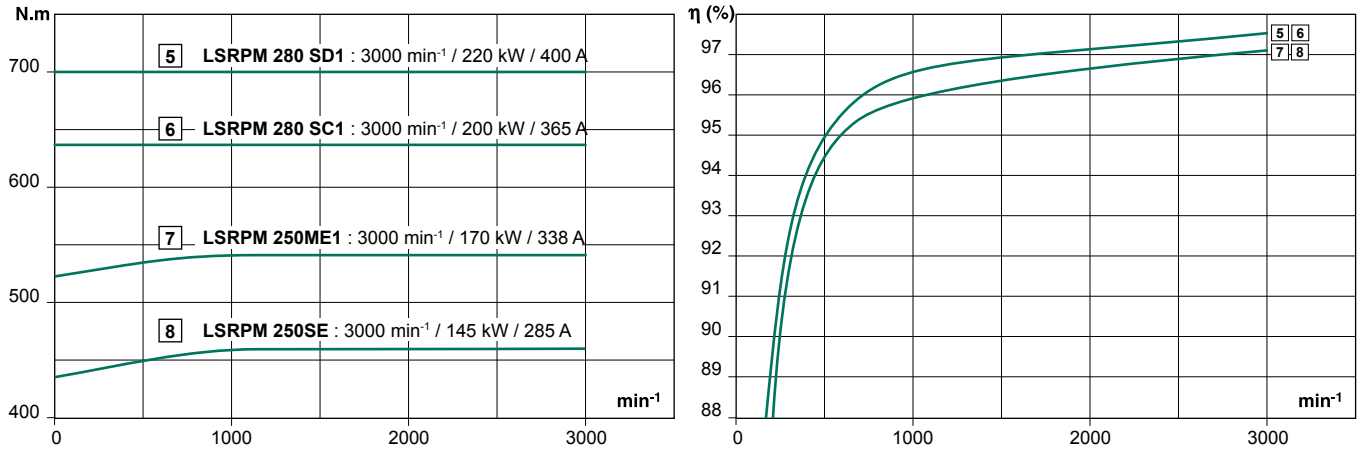

### A4.5 - Torque from 700 to 1080 N.m

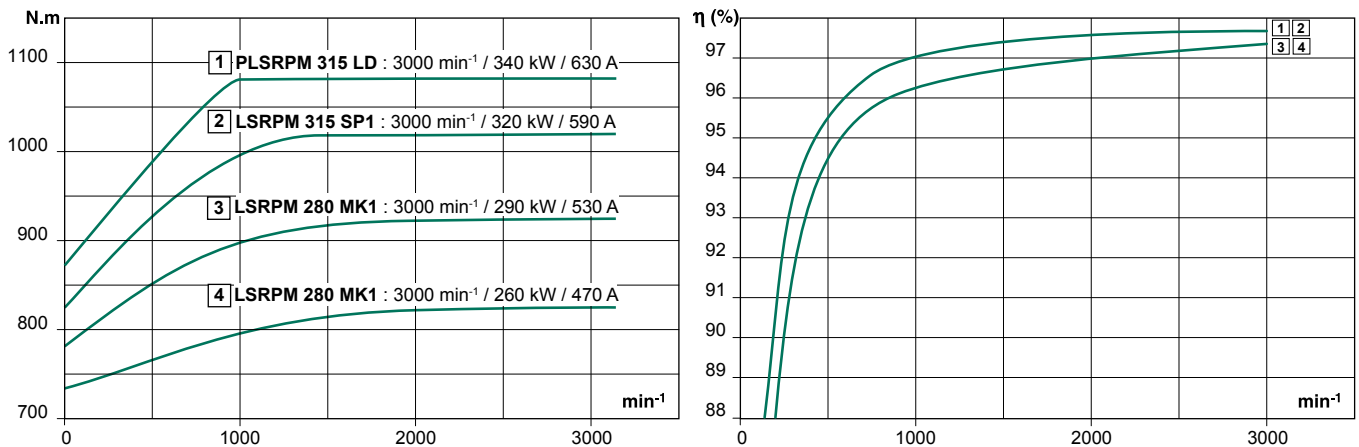

For operation at very low speeds, see the equipment and options section, pages 26, 27 and 28.

# Permanent magnet synchronous motors LSRPM - PLSRPM Performance

## A5 - 2400 range, 0 to 2400 min<sup>-1</sup>

### A5.1 - Torque from 0 to 38 N.m

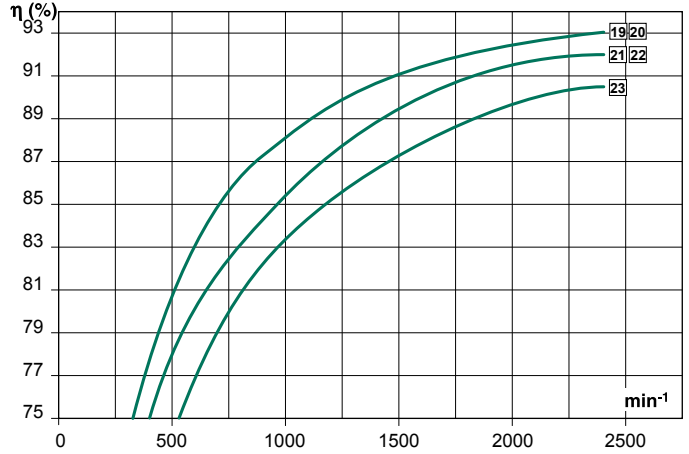
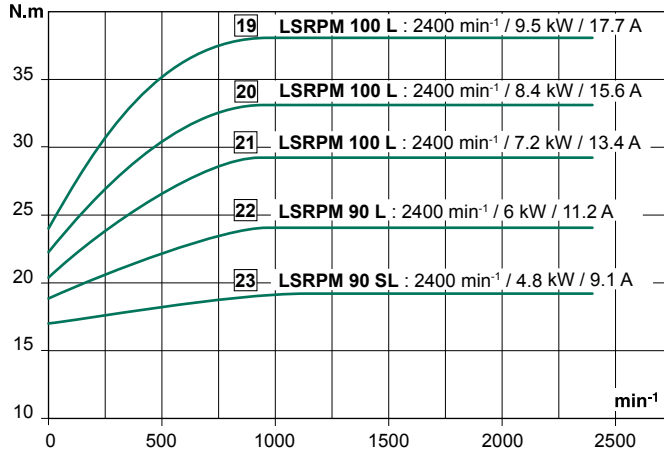

### A5.2 - Torque from 38 to 145 N.m

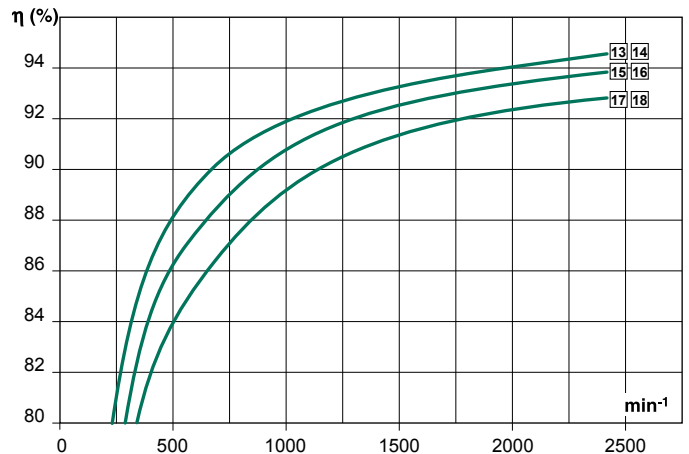
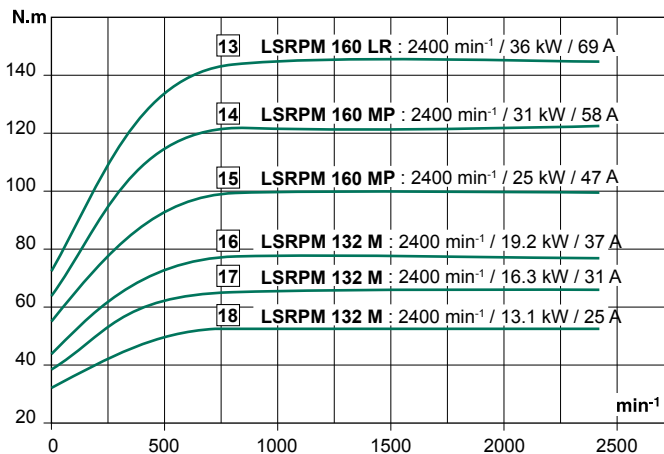

### A5.3 - Torque from 145 to 400 N.m

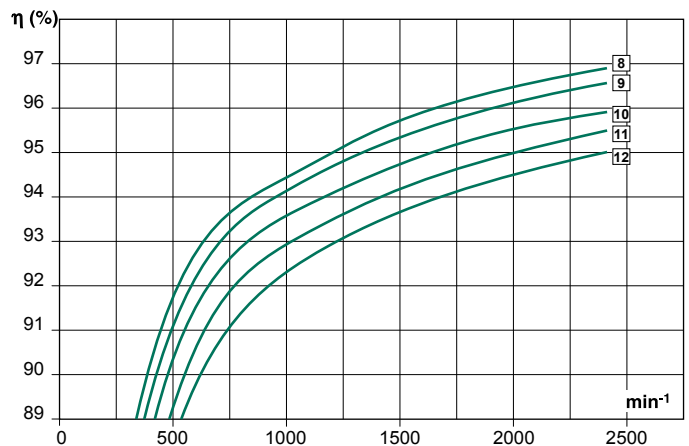
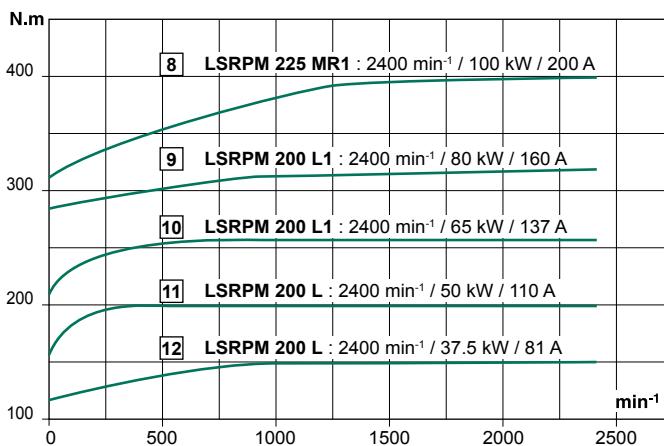

For operation at very low speeds, see the equipment and options section, pages 26, 27 and 28.

# Permanent magnet synchronous motors

## LSRPM - PLSRPM

### Performance

## A5 - 2400 range, 0 to 2400 min<sup>-1</sup>

### A5.4 - Torque from 400 to 755 N.m

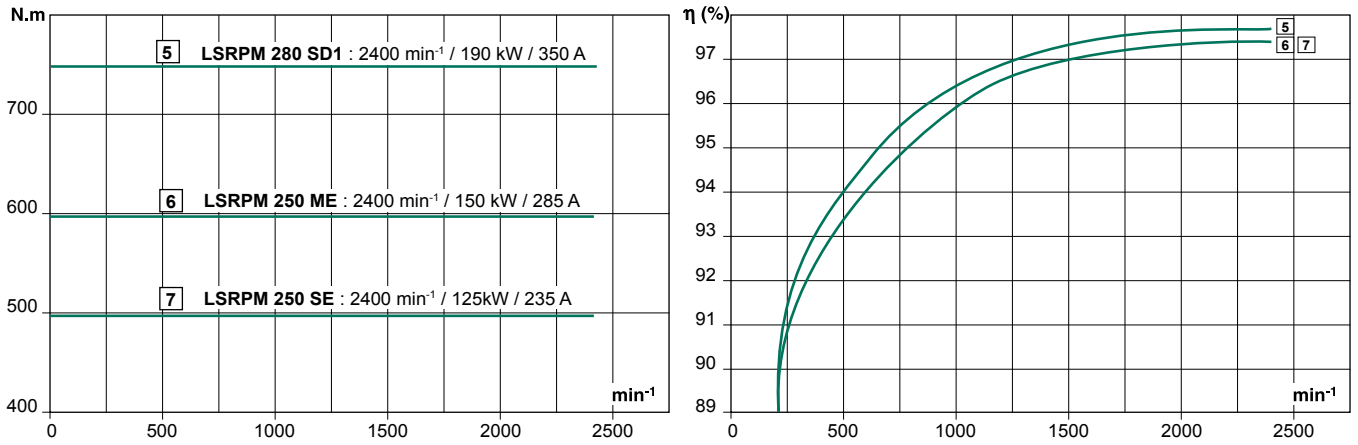

### A5.5 - Torque from 755 to 1390 N.m

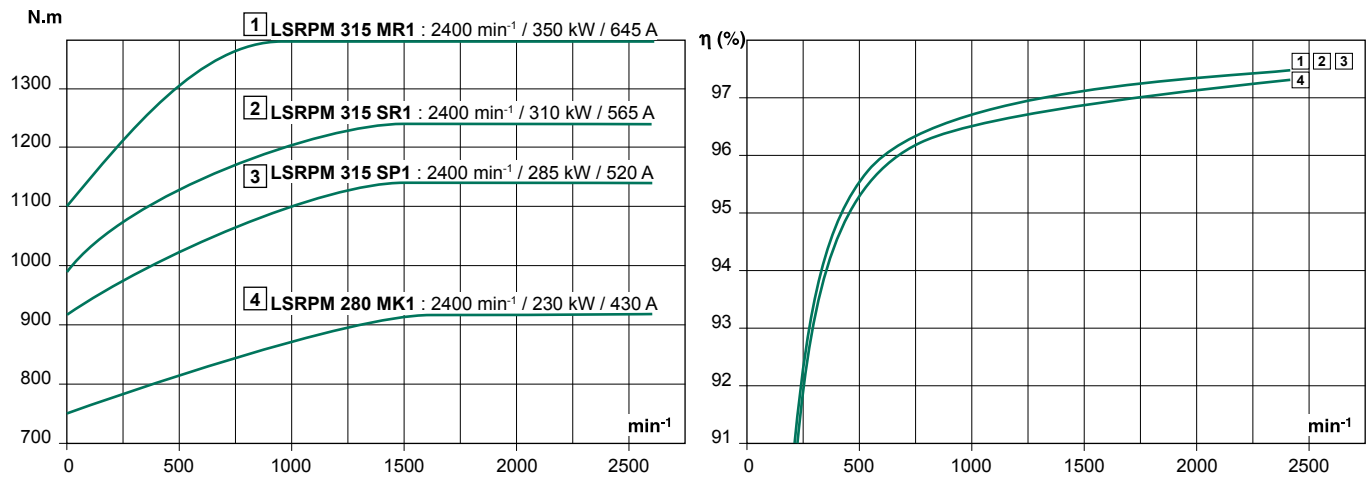

For operation at very low speeds, see the equipment and options section, pages 26, 27 and 28.

# Permanent magnet synchronous motors LSRPM - PLSRPM Performance

## A6 - 1800 range, 0 to 1800 min<sup>-1</sup>

### A6.1 - Torque from 0 to 38 N.m

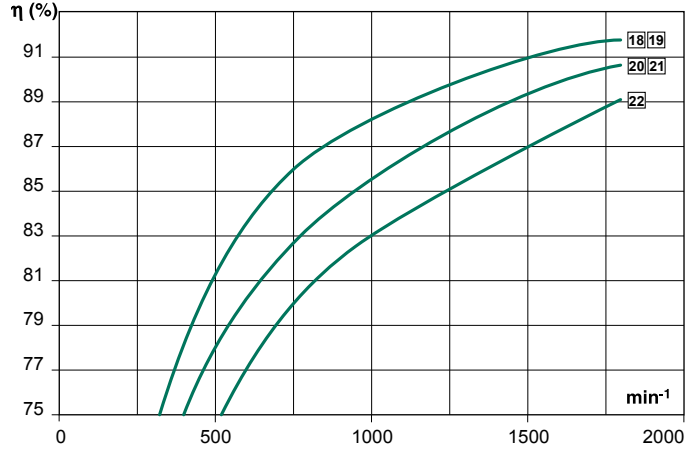
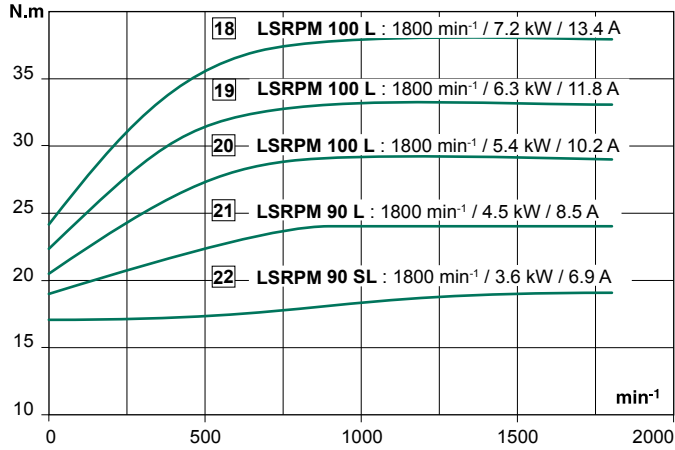

### A6.2 - Torque from 38 to 145 N.m

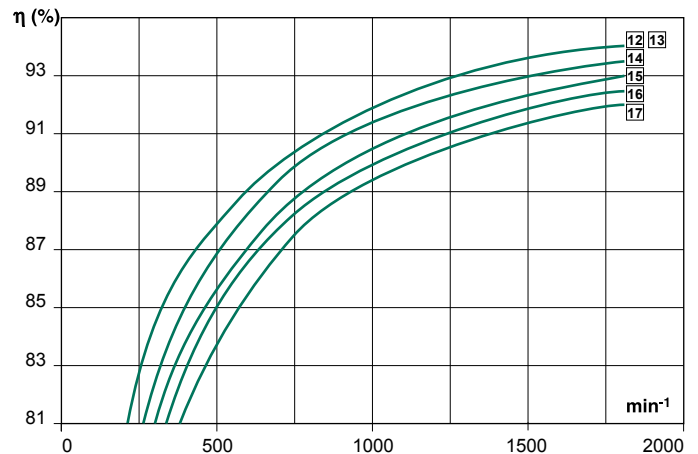
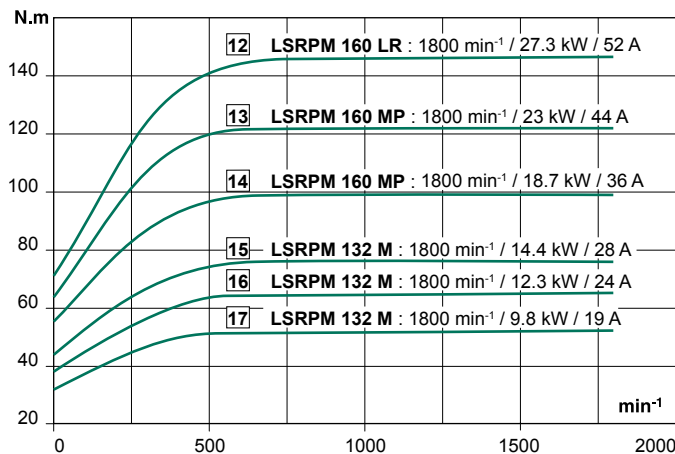

### A6.3 - Torque from 145 to 370 N.m

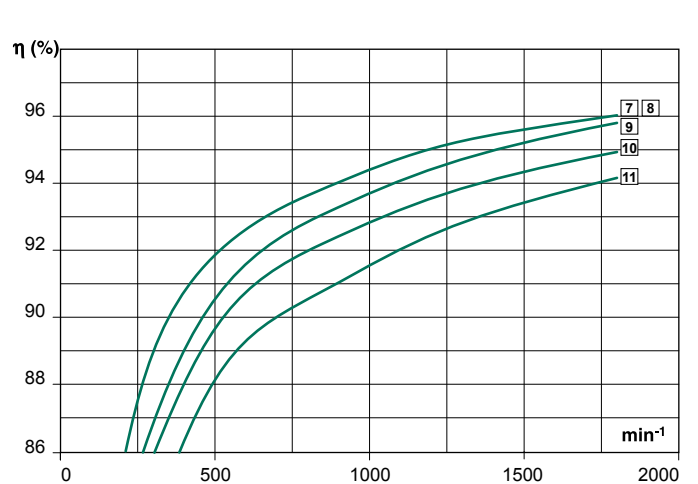
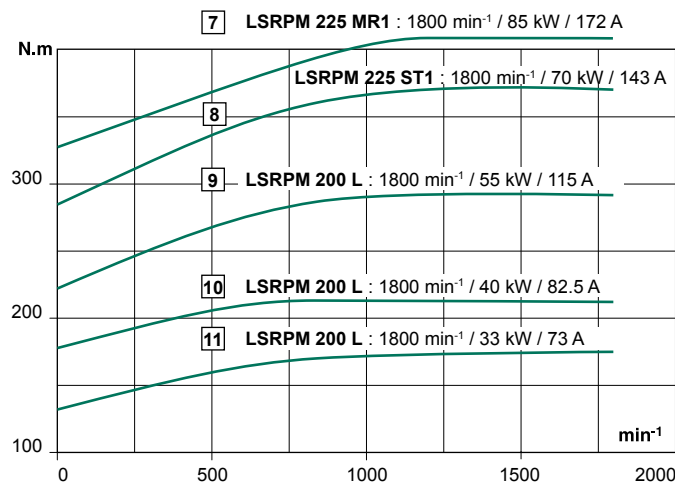

For operation at very low speeds, see the equipment and options section, pages 26, 27 and 28.

# Permanent magnet synchronous motors LSRPM - PLSRPM Performance

## A6 - 1800 range, 0 to 1800 min<sup>-1</sup>

### A6.4 - Torque from 370 to 800 N.m

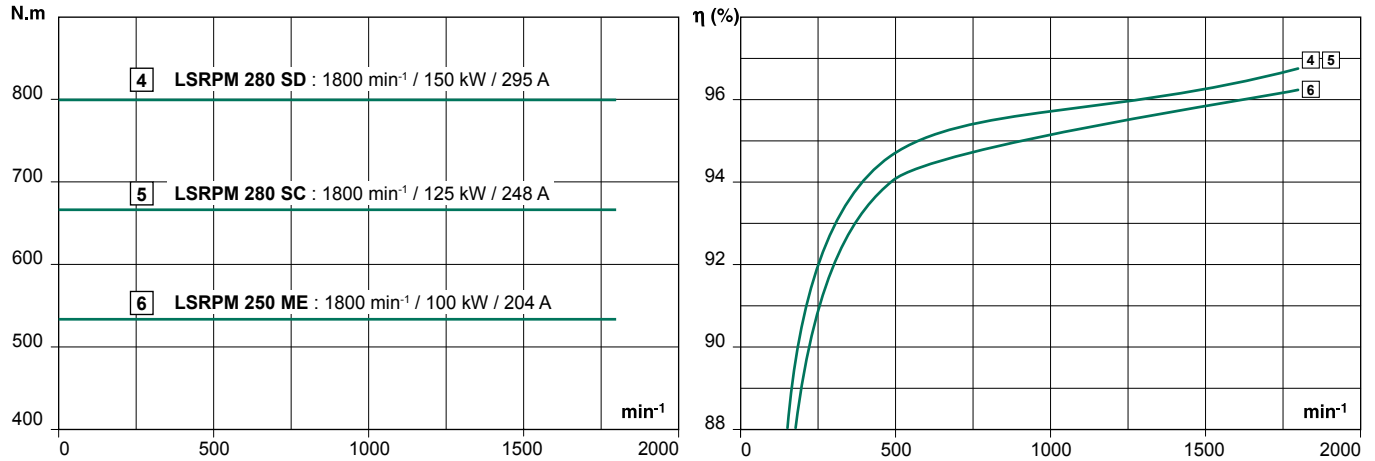

### A6.5 - Torque from 800 to 1220 N.m

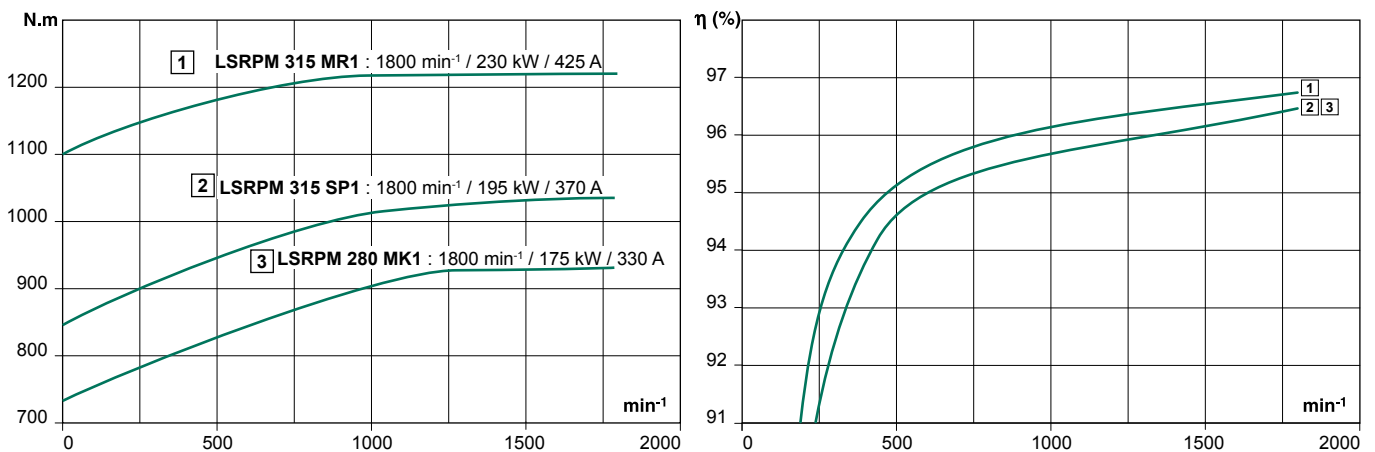

For operation at very low speeds, see the equipment and options section, pages 26, 27 and 28.

# Permanent magnet synchronous motors LSRPM - PLSRPM Performance

## A7 - 1500 range, 0 to 1500 min<sup>-1</sup>

### A7.1 - Torque from 0 to 38 N.m

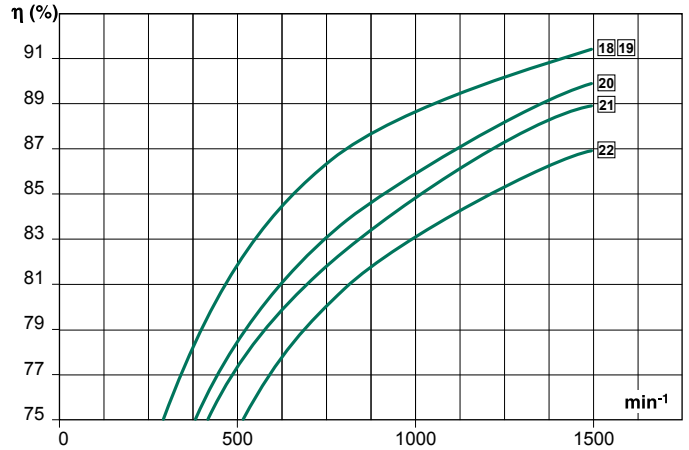
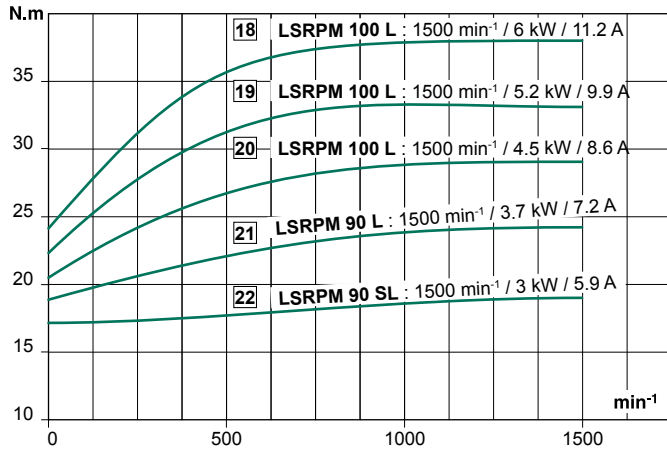

### A7.2 - Torque from 38 to 145 N.m

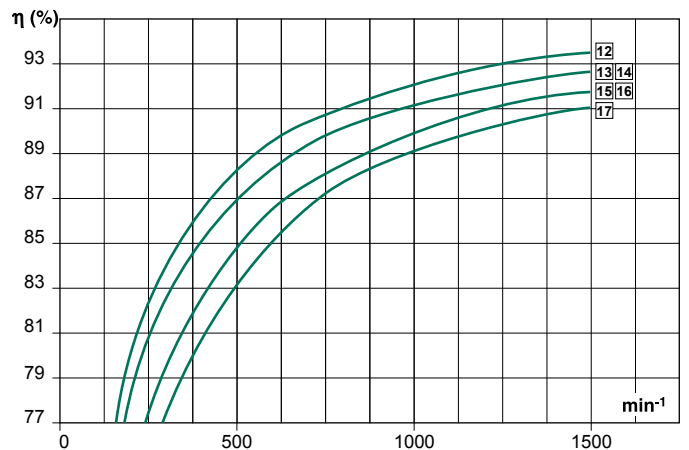
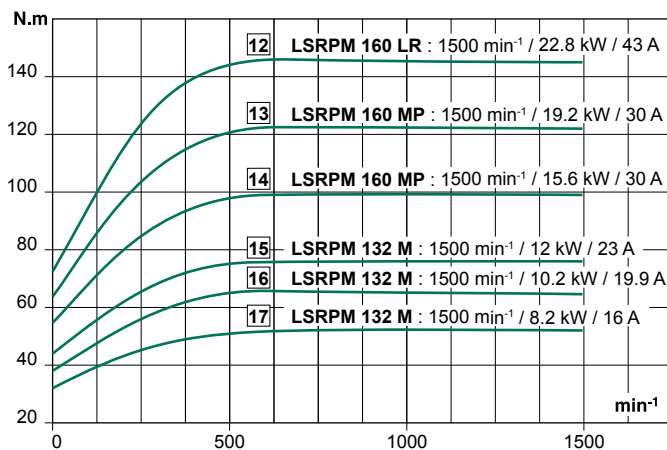

### A7.3 - Torque from 145 to 350 N.m

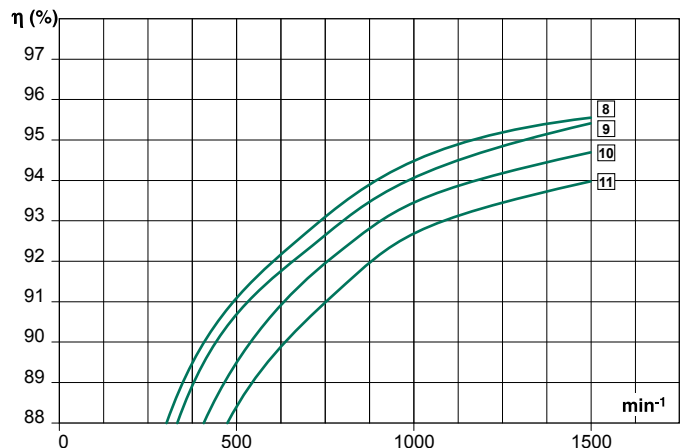
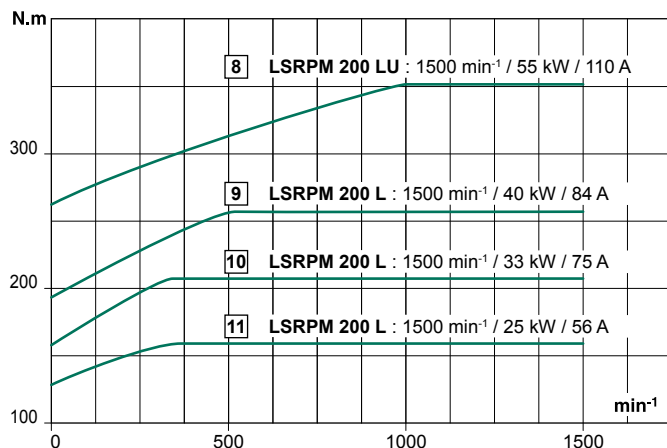

For operation at very low speeds, see the equipment and options section, pages 26, 27 and 28.

# Permanent magnet synchronous motors LSRPM - PLSRPM Performance

## A7 - 1500 range, 0 to 1500 min<sup>-1</sup>

### A7.4 - Torque from 350 to 800 N.m

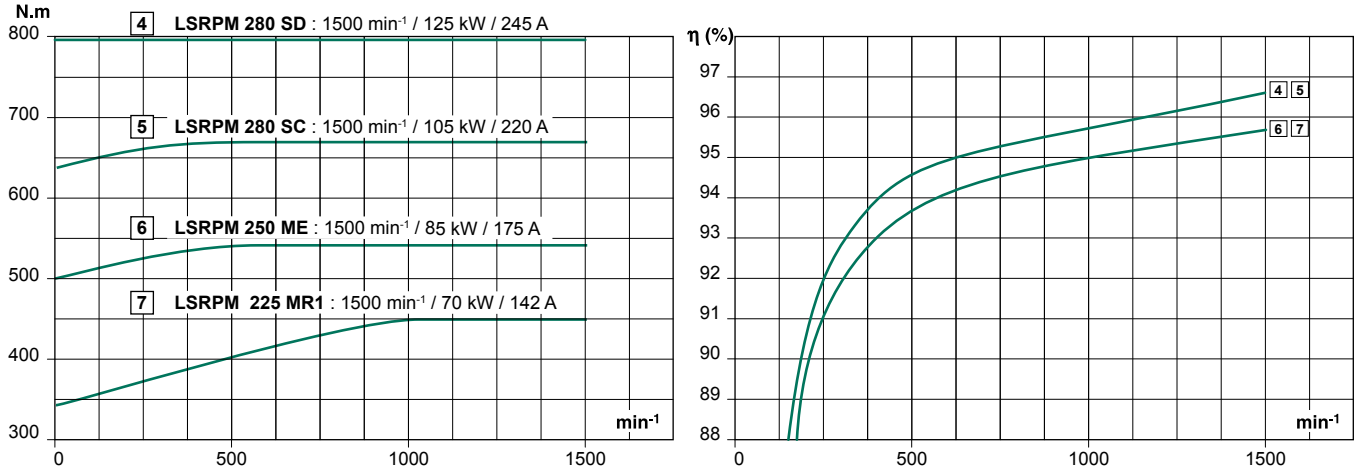

### A7.5 - Torque from 800 to 1400 N.m

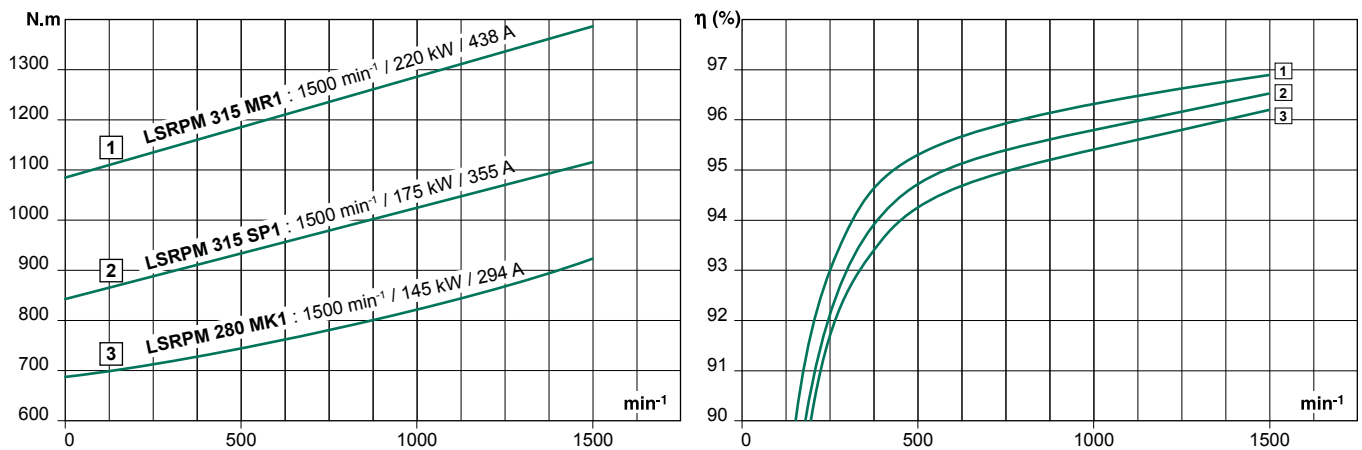

For operation at very low speeds, see the equipment and options section, pages 26, 27 and 28.

# Permanent magnet synchronous motors LSRPM - PLSRPM Performance

## A8 - 900 range, 0 to 900 min<sup>-1</sup>

### A8.1 - Torque from 0 to 38 N.m

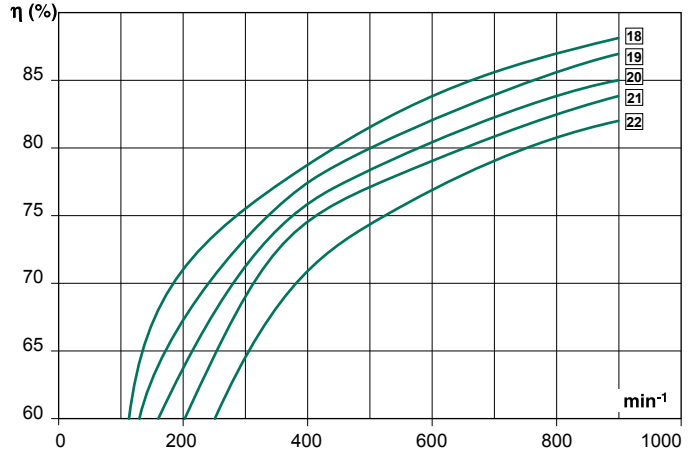
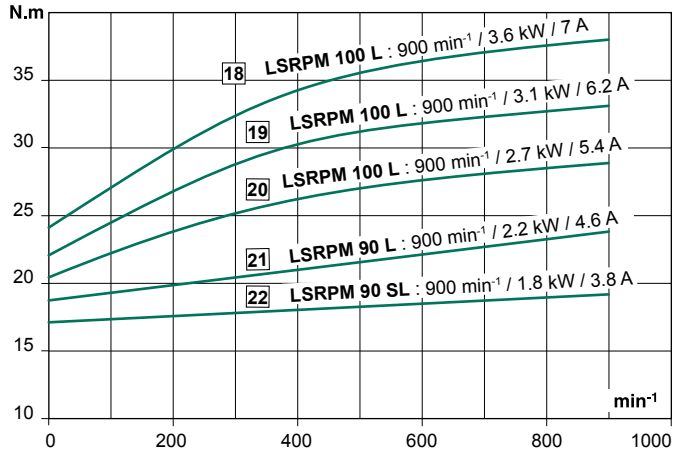

### A8.2 - Torque from 38 to 145 N.m

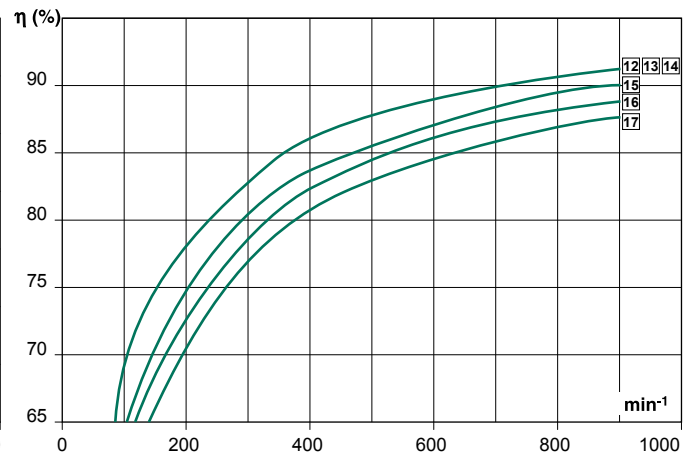
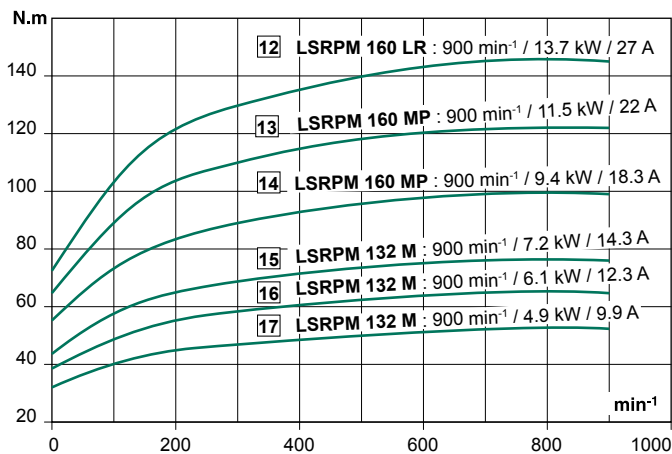

### A8.3 - Torque from 145 to 350 N.m

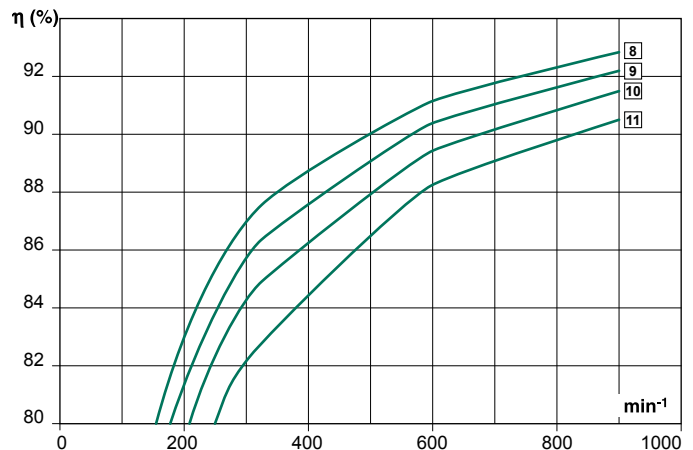
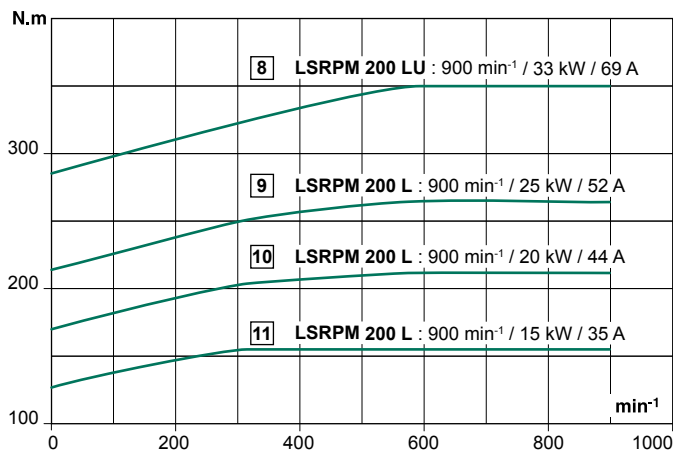

For operation at very low speeds, see the equipment and options section, pages 26, 27 and 28.

# Permanent magnet synchronous motors LSRPM - PLSRPM Performance

A8 - 900 range, 0 to 900 min<sup>-1</sup>

## A8.4 - Torque from 350 to 800 N.m

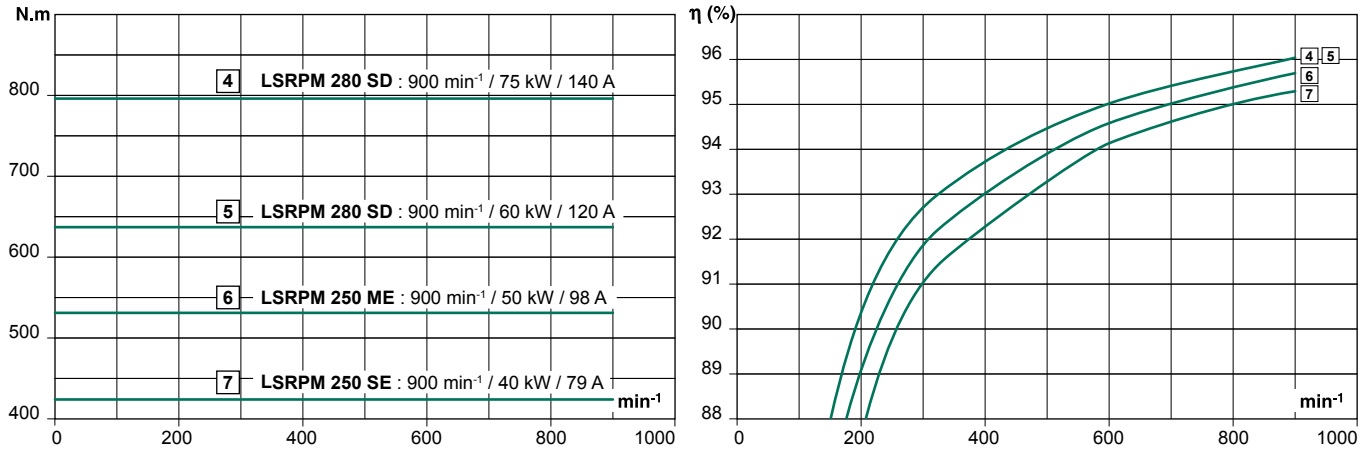

## A8.5 - Torque from 800 to 1380 N.m

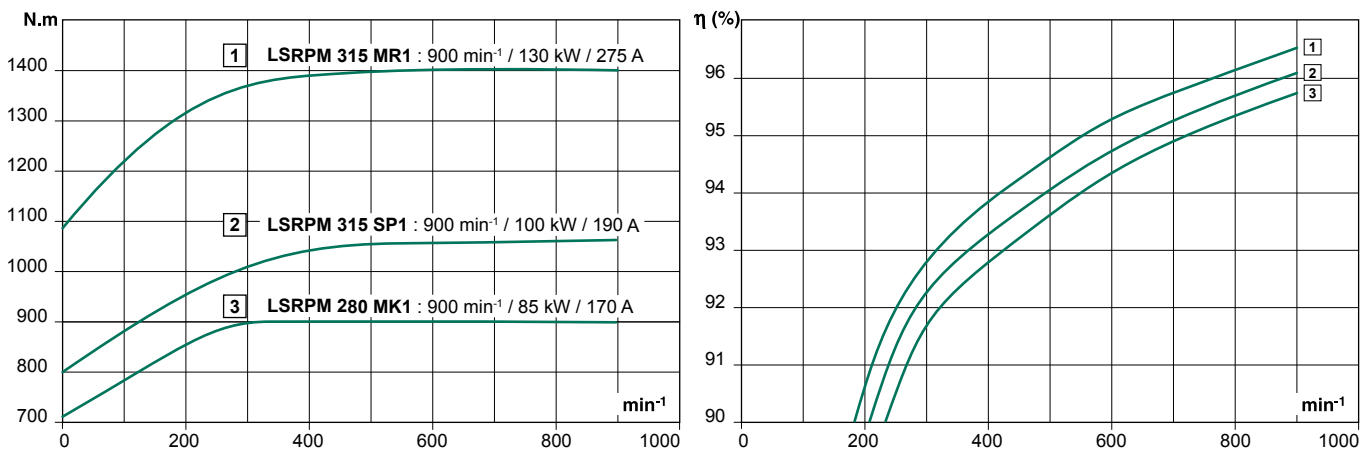

For operation at very low speeds, see the equipment and options section, pages 26, 27 and 28.

# Permanent magnet synchronous motors LSRPM - PLSRPM Performance

## A9 - 750 range, 0 to 750 min<sup>-1</sup>

### A9.1 - Torque from 0 to 37 N.m

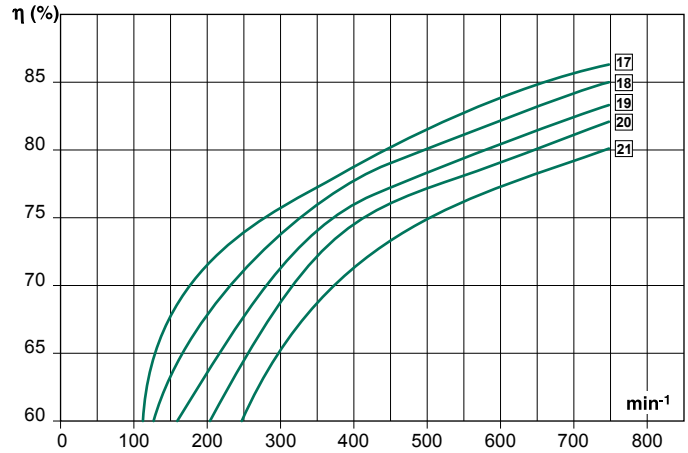
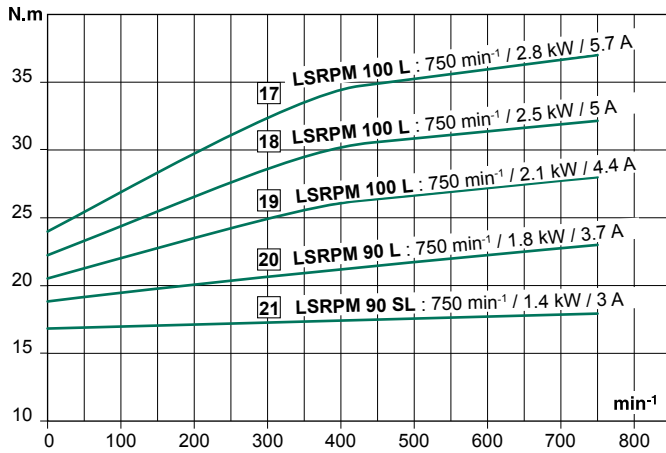

### A9.2 - Torque from 37 to 145 N.m

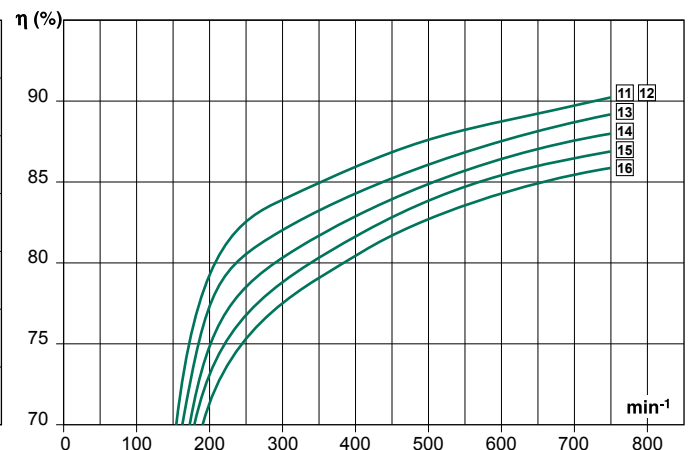
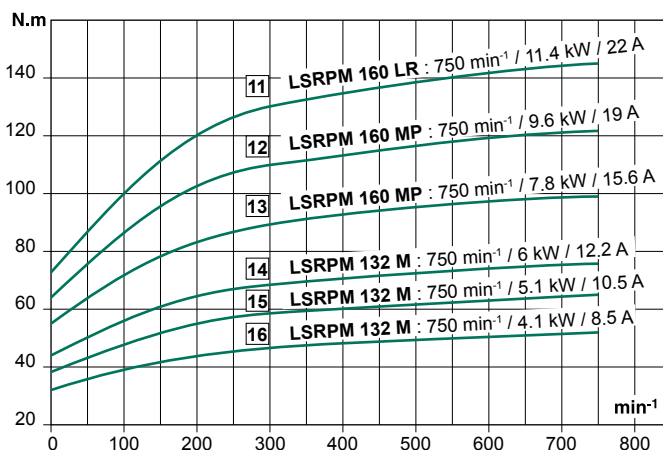

### A9.3 - Torque from 145 to 345 N.m

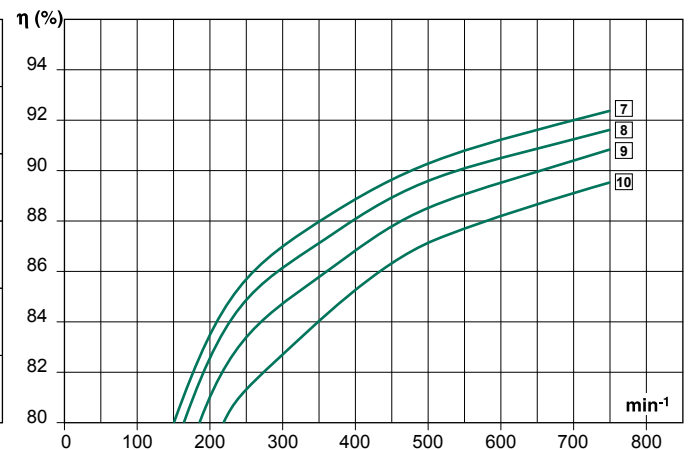
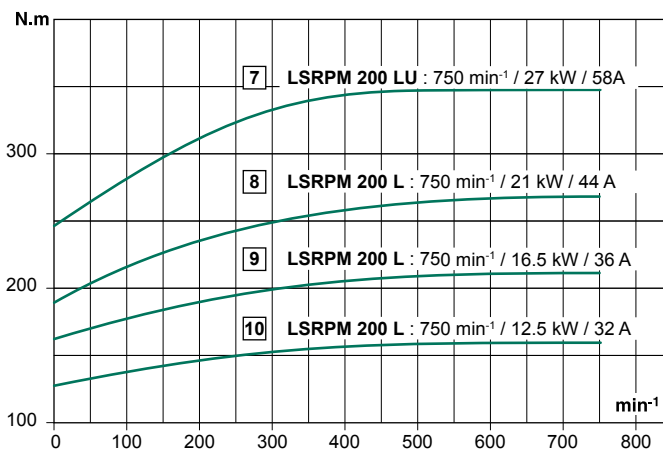

For operation at very low speeds, see the equipment and options section, pages 26, 27 and 28.

# Permanent magnet synchronous motors LSRPM - PLSRPM Performance

## A9 - 750 range, 0 to 750 min<sup>-1</sup>

### A9.4 - Torque from 345 to 890 N.m

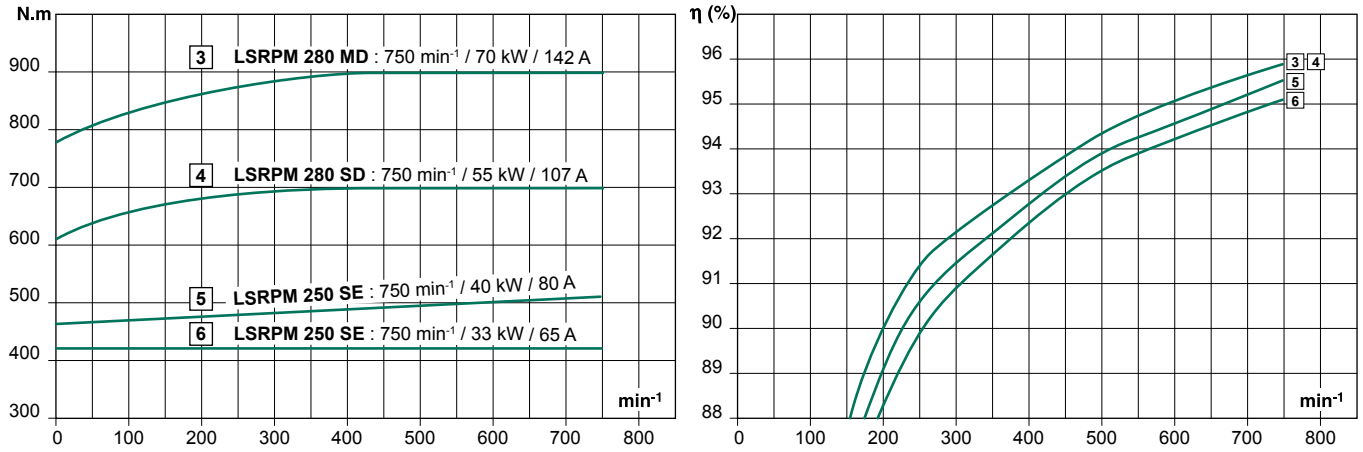

### A9.5 - Torque from 890 to 1400 N.m

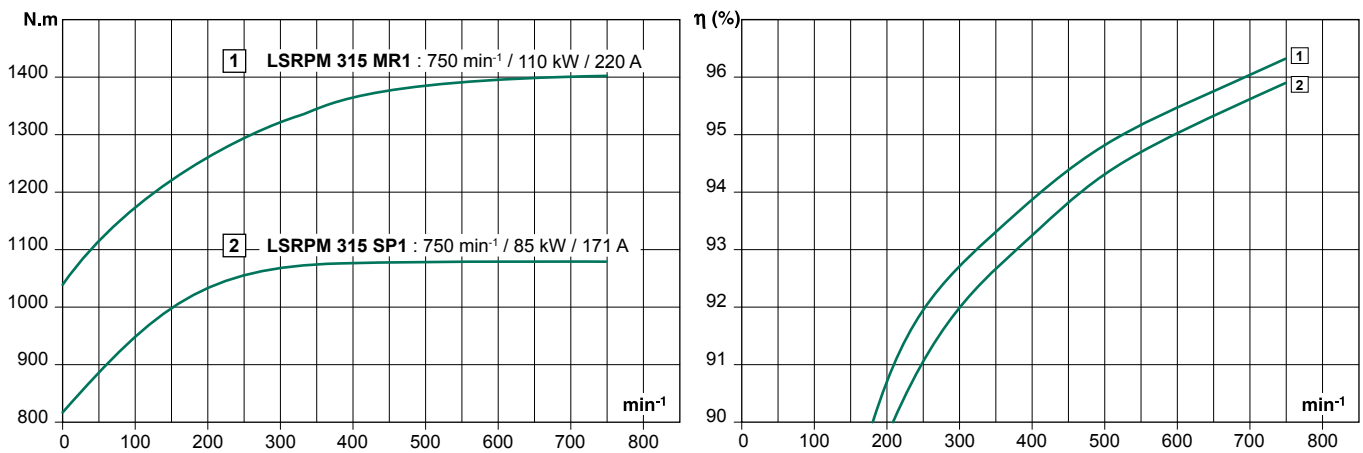

For operation at very low speeds, see the equipment and options section, pages 26, 27 and 28.

# Permanent magnet synchronous motors LSRPM - PLSRPM Performance

## A10 - 375 range, 0 to 375 min<sup>-1</sup>

### A10.1 - Torque from 0 to 34 N.m

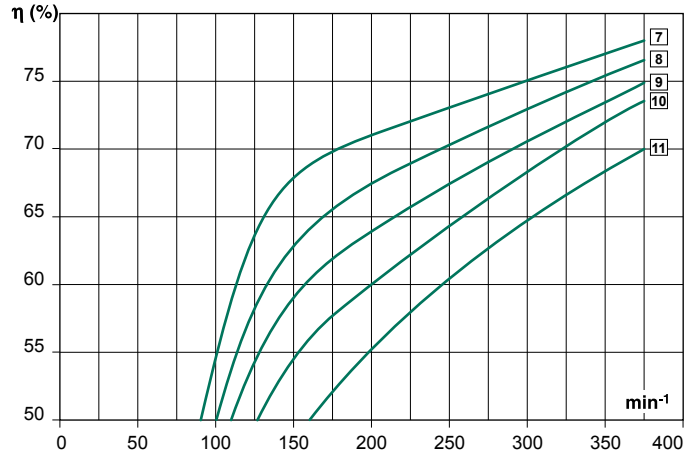
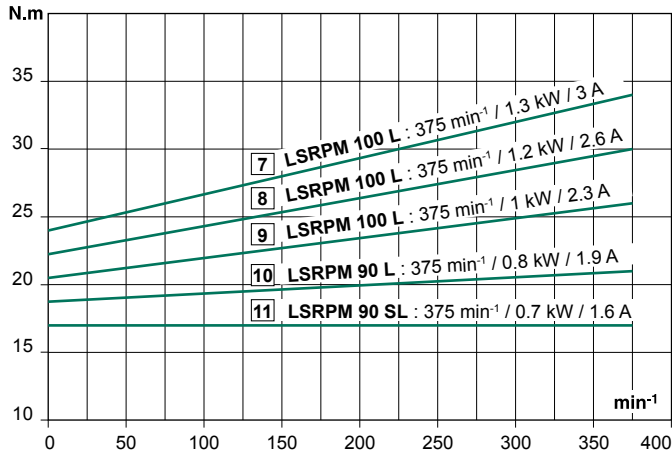

### A10.2 - Torque from 34 to 130 N.m

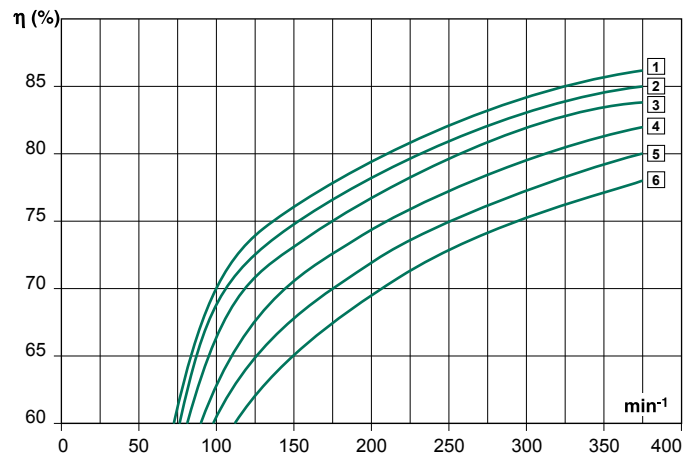
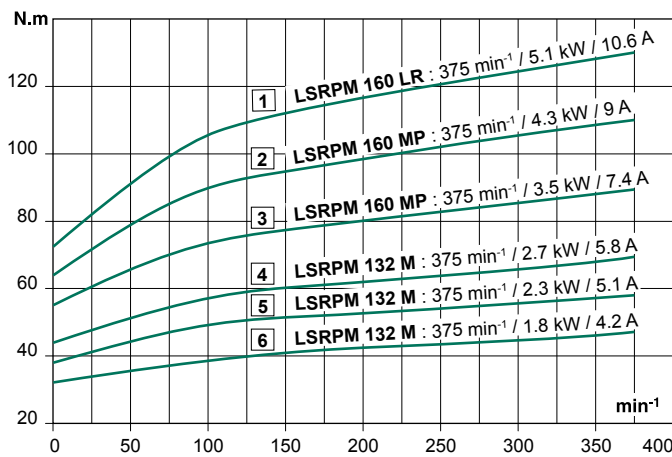

For operation at very low speeds, see the equipment and options section, pages 26, 27 and 28.

# Permanent magnet synchronous motors LSRPM - PLSRPM Equipment and options

PAGES

## B1 - Position sensor 26 to 27

Selection of position sensor .....	26
Hall effect sensor .....	27
Encoder option .....	27

## B2 - Forced ventilation 28

## B3 - Reinforced insulation 29

Reinforced winding insulation .....	29
Reinforced insulation of the mechanical parts .....	29

## B4 - Cable glands 30

## B5 - Thermal protection 31

# Permanent magnet synchronous motors

## LSRPM - PLSRPM

### Equipment and options

## B1 - Position sensor

### B1.1 - SELECTION OF POSITION SENSOR

In order to operate correctly, the drive must know the position of the rotor with respect to the stator at all times. For this reason, permanent magnet synchronous motors are fitted as standard with a position sensor.

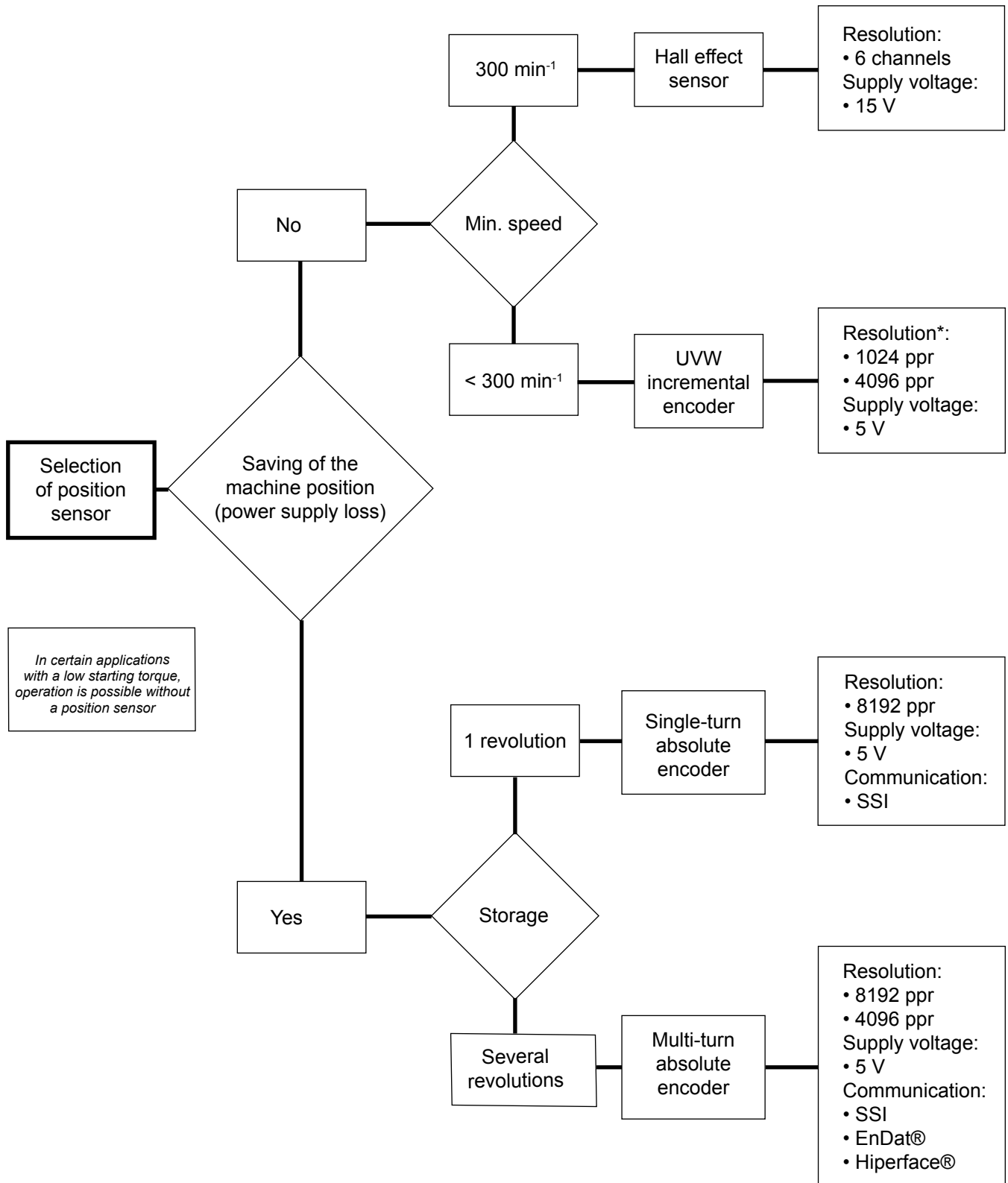

\* Caution, if the speed is greater than or equal to 3000 min<sup>-1</sup>, the resolution must not exceed 1024 ppr.

# Permanent magnet synchronous motors LSRPM - PLSRPM Equipment and options

## B1 - Position sensor

### B1.2 - HALL EFFECT SENSOR

#### B1.2.1 - Description

Hall effect sensors can be used to detect magnetic fields. Knowing the position to within about 60 electrical degrees is sufficient for their use on Leroy-Somer drives in applications where a stability below 300 rpm is not required.

#### B1.2.2 - Connection

The connection is done on a terminal block in the terminal box.

Colour	Green		Yellow		Grey		White	Brown	Shielding
Connection	U	W/	V	U/	W	V/	0V	+15V	
Terminal number	1	2	3	4	5	6	7	8	9

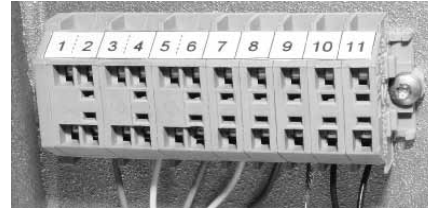

### B1.3 - ENCODER OPTION

#### B1.3.1 - UVW incremental encoder

This pulse generator supplies a number of pulses on channels AA BB top 0, top 0 proportional to the speed. The information on commutation channels UVW enables the position of the rotor to be known to within about 60 electrical degrees.

A 1024 ppr encoder is sufficient for most applications. However, where stability at very low speed (<10 rpm) is required, use of a higher resolution encoder is recommended.

#### B1.3.2 - Single-turn absolute encoder

The single-turn absolute encoder converts a rotation of the drive shaft into a series of «electrical encoded steps». The number of steps per revolution is determined by an optical disk. In general, one shaft rotation consists of 8192 steps, which corresponds to 13 bits. At the end of a complete encoder shaft revolution, the same values are repeated.

#### B1.3.3 - Multi-turn absolute encoder

The multi-turn absolute encoder saves the position in the revolution and also over several revolutions, with a maximum of 4096 revolutions.



#### B1.3.4 - Encoder characteristics

	UVW INCREMENTAL ENCODER	ABSOLUTE ENCODERS				
		ECN 413 single-turn	SRS 64 single-turn	PHO 514 multi-turn	EQN 425 multi-turn	SRM 64 multi-turn
Supply voltage	5 - 30 Vdc	10 - 30 Vdc 5 Vdc +/- 5 %	7...12 Vdc	5 - 30 Vdc	10 - 30 Vdc 5 Vdc +/- 5 %	7...12 Vdc
Positions per revolution as standard 1 to 4096 ppr on request	1024 or 4096	4096 max : 8192	4096	4096 max : 8192	4096 max : 8192	4096 max : 8192
Output stage	TTL	1V ~	1V ~	1V ~	1V ~	1V ~
Max. current (no load)	150 mA	150 mA	80 mA	100 mA	250 mA	80 mA
Max. mechanical speed in continuous	10000 min <sup>-1</sup>	12000 min <sup>-1</sup>	6000 min <sup>-1</sup>	6000 min <sup>-1</sup>	10000 min <sup>-1</sup>	6000 min <sup>-1</sup>
Max. scan rate	300 kHz	100 kHz	200 kHz	100 kHz	100 kHz	200 kHz
Shaft diameter	14 mm THS*	14 mm THS*	14 mm THS*	14 mm THS*	14 mm THS*	14 mm THS*
Protection	IP65	IP64	IP65	IP65	IP64	IP65
Operating temperature	-30° +100 °C	-40° +100 °C	-20° +110 °C	-20° +85 °C	-40° +85 °C	-20° +110 °C
Storage temperature	-40° +80 °C	-40° +105 °C	-20° +115 °C	-20° +85 °C	-40° +80 °C	-20° +115 °C
Data interface		SSI EnDat®	SSI Hiperface®	SSI	SSI EnDat®	SSI Hiperface®
Max. cable length	100 m	100 m	100 m	100 m	100 m	100 m

\*THS : Through Hollow Shaft

The dimensions of LSRPM-PLSRPM motors equipped with an encoder are given on page 46

# Permanent magnet synchronous motors

## LSRPM - PLSRPM

### Equipment and options

## B2 - Forced ventilation

Motors are self-cooled as standard

To keep the rated torque over the entire speed range, forced ventilation may be necessary.

**Characteristics of forced ventilation units for ranges up to 3600 inclusive**  
(consult Leroy-Somer for ranges 4500 and 5500)

Motor type	Supply voltage <sup>1</sup>	Consumption		Protection index <sup>2</sup>
		P (W) W	I (A) A	
LSRPM 90 to 132	single-phase 230 ou 400V	100	0.43/0.25	IP 55
LSRPM 160 to 280S	3-phase 230/400V 50Hz 254/460V 60Hz	150	0.94/0.55	IP 55
LSRPM 280M to 315	3-phase 230/400V 50Hz 254/460V 60Hz	200	1.4/0.8	IP 55
LSRPM 315M	3-phase 230/400V 50Hz 254/460V 60Hz	750	3.6/2.1	IP 55
PLSRPM 315LD	3-phase 230/400V 50Hz 254/460V 60Hz	3000	10.9/6.3	IP 55

<sup>1</sup>  $\pm 10\%$  for voltage,  $\pm 2\%$  for frequency.

<sup>2</sup> Protection index of the forced ventilation installed on the motor.

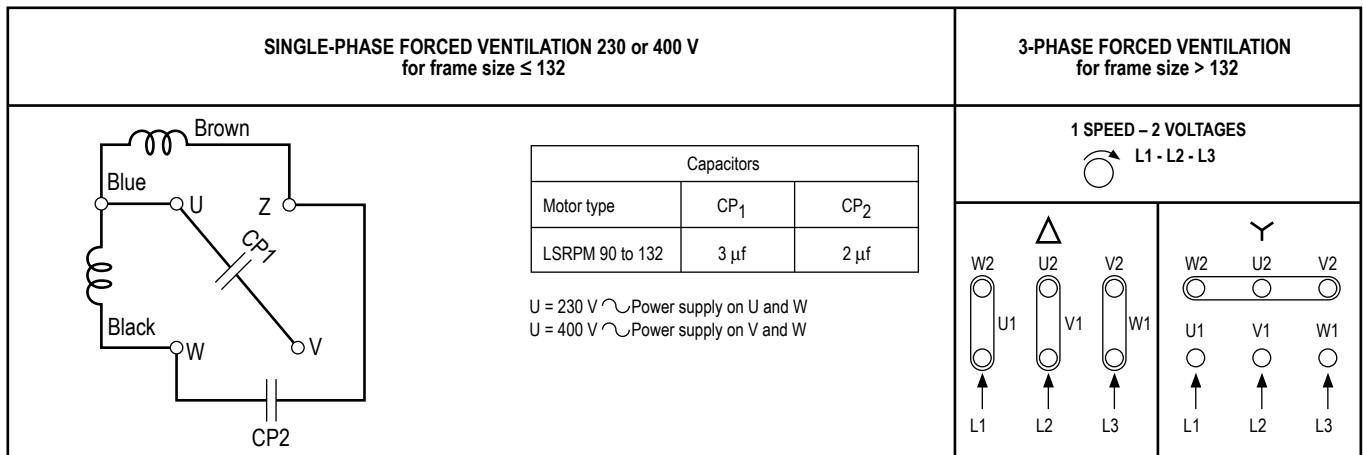

The dimensions of LSRPM-PLSRPM motors equipped with forced ventilation are given on page 46

# Permanent magnet synchronous motors LSRPM - PLSRPM Equipment and options

## B3 - Reinforced insulation

Motors fitted with insulated bearings are specified on page 52

Standard motors are compatible with power supplies with the following characteristics:

- $U_{rms} = 480V$  max.
- Value of voltage peaks generated at the terminals: 1500V max.
- Switching frequency: 2.5 kHz min.

However, they may be supplied under more severe conditions if additional protection is provided.

### B3.1 - REINFORCED WINDING INSULATION

The main effect connected with supplying power via an electronic drive is overheating of the motor due to the non-sinusoidal nature of the the output waveforms. This phenomena, combined with high frequency repetitive peak voltages generated at the leading and lagging edges of pulses in the supply voltage waveform, can lead to accelerated aging of the winding. (see Figure 1).

For peak voltages greater than 1500V, reinforced-insulation option is available.

### B3.2 - REINFORCED INSULATION OF THE MECHANICAL PARTS

Same phenomena which affects the insulation system of a winding i.e. high switching frequencies and rate of rise of peak voltage, could affect the mechanical parts as well, particularly the rolling elements. These

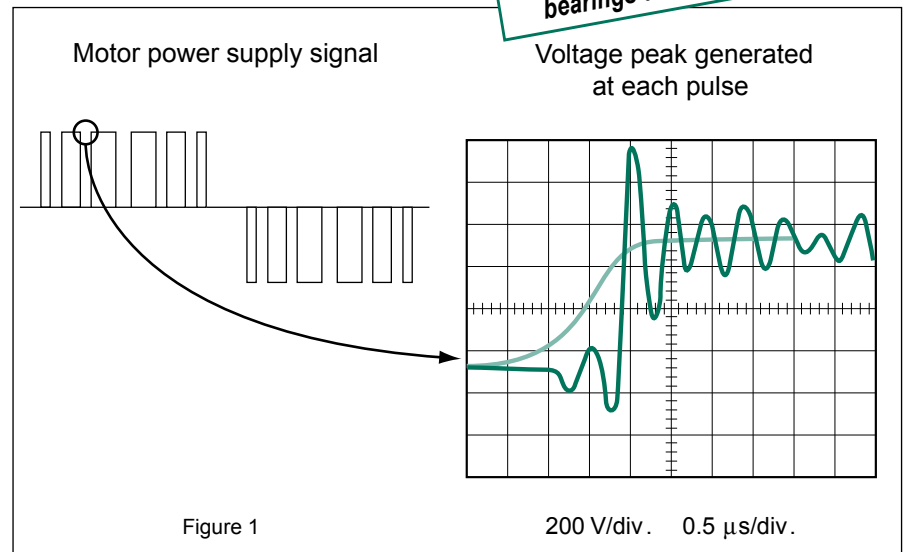

are associated with inherent magnetic assymetries or with unbalanced excitation of the winding or combination of both. But, when a motor is fed via a Pulse Width Modulated (PWM), the situation is exacerbated and this could result in premature wear of bearings.

If power is supplied via a PWM drive, high frequency currents generated by the IGBT output bridges of the drives, «attempt» to

spread towards the drive and therefore flow through the stator and via earth where the link between casing, machine chassis and earth is correctly made.

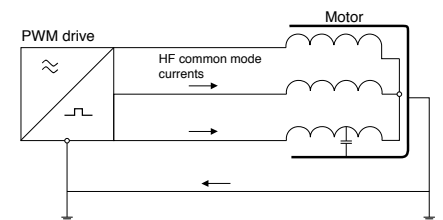

Otherwise, they will flow via the least resistive path: end shields/bearings/shaft/ machine coupled to the motor. In these situations, therefore, protection for the bearings must be provided.

For this reason, an «insulated bearing» option is available over the entire range from a frame size of 200.

The outer races of the bearings are coated with a layer of electrically insulating ceramic. The dimensions and tolerances of these bearings are identical to the standard ones used and can therefore be fitted instead, with no modifications to the motors. The breakdown voltage is 500 V.

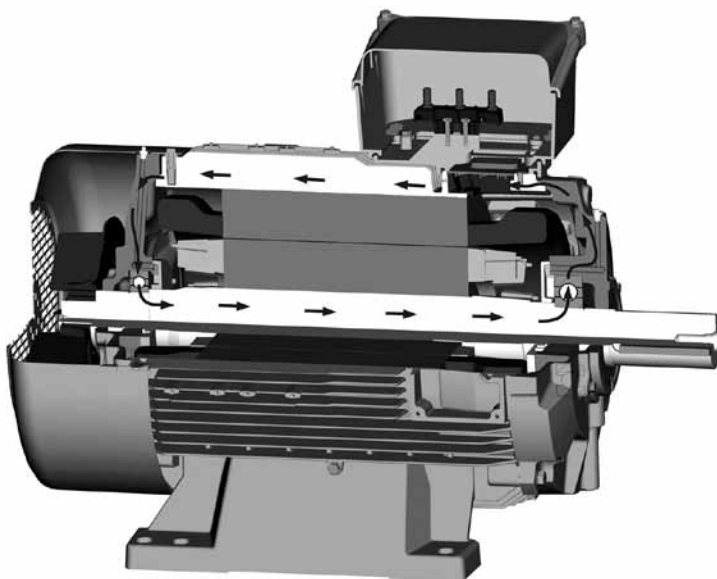

# Permanent magnet synchronous motors LSRPM - PLSRPM Equipment and options

## B4 - Cable glands

The motors are supplied with pre-drilled and tapped terminal boxes or undrilled mounting plate for mounting cable glands, see page 53

In certain applications, it is necessary for there to be earth continuity between the cable and the motor earth to ensure protection of the installation in accordance with the EMC directive, 89/336/EEC.

An option of **cable gland permitting 360° bonding with the screened cable** is therefore available over the entire speed range.

### Type and cable size capacity of cable glands

Cable gland type	Cable size capacity	
	Min. cable Ø (mm) W	Max. cable Ø (mm) A
ISO 16	6	11
ISO 20	7.5	13
ISO 25	12.5	18
ISO 32	17.5	25
ISO 40	24.5	33.5
ISO 50	33	43
ISO 63	42.5	55

# Permanent magnet synchronous motors

## LSRPM - PLSRPM

### Equipment and options

## B5 - Thermal protection

Motors are fitted with PTC sensors as standard

The motors are protected by the variable speed drive, placed between the isolating switch and the motor.

The variable speed drive helps to provide total protection of the motor against overloads.

Motors are fitted with PTC sensors in the winding. As an option, specific thermal protection sensors can be selected from the table below.

**It must be emphasized that under no circumstances can these sensors be used to carry out direct regulation of the motor operating cycles.**

### Built-in indirect thermal protection

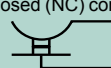
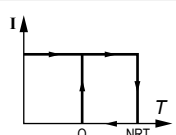
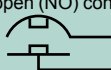
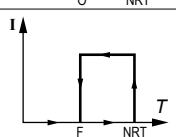
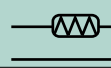
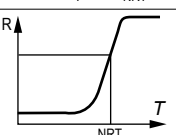
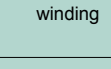
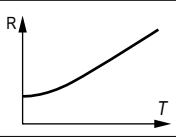
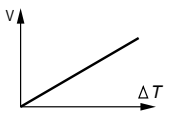
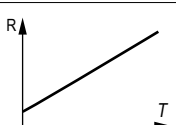
Type	Operating principle	Operating curve	Breaking capacity (A)	Protection provided	Mounting Number of devices*
Normally closed thermal protection <b>PTO</b>	Bimetallic strip, indirectly heated, with normally closed (NC) contact 		2.5 A at 250 V with $\cos \varphi 0.4$	General monitoring for non-transient overloads	Mounting in control circuit 2 or 3 in series
Normally open thermal protection <b>PTF</b>	Bimetallic strip, indirectly heated, with normally open (NO) contact 		2.5 A at 250 V with $\cos \varphi 0.4$	General monitoring for non-transient overloads	Mounting in control circuit 2 or 3 in parallel
Positive temperature coefficient thermistor <b>PTC</b>	Non-linear variable resistance, indirectly heated 		0	General monitoring for transient overloads	Mounted with associated relay in control circuit 3 in series
Temperature sensor <b>KT Y</b>	Resistance depends on the temperature of the winding 		0	Continuous monitoring with high accuracy at key hot spots	Mounted in control boards with associated reading equipment (or recorder) 1 per hot spot
Thermocouples <b>T</b> ( $T < 150\text{ }^{\circ}\text{C}$ ) Constantan copper <b>K</b> ( $T < 1000\text{ }^{\circ}\text{C}$ ) Copper/copper-nickel	Peltier effect		0	Continuous monitoring at regular intervals at hot spots	Mounted in control boards with associated reading equipment (or recorder) 1 per hot spot
Platinum temperature sensor <b>PT 100</b>	Linear variable resistance, indirectly heated		0	Continuous monitoring with high accuracy at key hot spots	Mounted in control boards with associated reading equipment (or recorder) 1 per hot spot

- NRT: Nominal running temperature

- The NRTs are chosen according to the position of the sensor in the motor and the temperature rise class.

\* The number of devices relates to the winding protection.

### Fitting thermal protection

- PTO or PTF, in the control circuits.

- PTC, with associated relay, in the control circuits.

- PT 100 or Thermocouples, with associated reading equipment or recorder, in the control boards of installations for continuous monitoring.

### Alarm and early warning

All protective equipment can be backed up by another type of protection (with a different normal running temperature, NRT). The first device will then act as an «early warning» (light or sound signals given without shutting down the power circuits), and the second device will be the actual alarm (shutting down the power circuits).

### Connection of PTC sensors

Terminal numbers: 10 and 11.





# Permanent magnet synchronous motors LSRPM - PLSRPM Electrical characteristics

PAGE

## C1 - Characteristic data

34 to 38

5500 range .....	34
4500 range .....	34
3600 range .....	35
3000 range .....	35
2400 range .....	36
1800 range .....	36
1500 range .....	37
900 range .....	37
750 range .....	38
375 range .....	38

The performances given are those motors used in conjunction with LEROY-SOMER drives.  
The values and tolerances conform to IEC 60034-1.

# Permanent magnet synchronous motors

## LSRPM - PLSRPM

### Electrical characteristics

#### C1 - Characteristic data

5500  
range

BASED ON INVERTER INPUT VOLTAGE OF 400 V ± 10%  
(in accordance with standard IEC 60034-1)

Type	Index of protection	Rated power	Rated speed	Rated torque	Rated current	Efficiency	(1) Max. torque/ Rated torque	(1) Max. current/ Rated current	Moment of inertia	Weight
		$P_N$ kW	$N_N$ min <sup>-1</sup>	$C_N$ N.m	$I_N$ A	$\eta$ %	$M_M/M_N$	$I_M/I_N$	$J$ kg.m <sup>2</sup>	IM B3 kg
LSRPM 90SL	IP55	6.9	5500	12	12.7	93.5	1.5	1.5	0.0032	14
LSRPM 90L	IP55	8.6	5500	15	15.2	94	1.5	1.5	0.0051	17
LSRPM 100L	IP55	10.4	5500	18	19	94	1.5	1.5	0.006	19
LSRPM 100L	IP55	12.1	5500	21	22	94.5	1.5	1.5	0.0078	24
LSRPM 100L	IP55	13.8	5500	24	25	94.5	1.5	1.5	0.009	26
LSRPM 132M	IP55	18.6	5500	32	35	94	1.5	1.5	0.0165	40
LSRPM 132M	IP55	23	5500	40	44	94	1.5	1.5	0.0231	44
LSRPM 132M	IP55	27	5500	47	52	94.5	1.5	1.5	0.0311	49
LSRPM 160MP	IP55	35	5500	62	67	94.5	1.5	1.5	0.0418	60
LSRPM 160MP	IP55	44	5500	76	82	95	1.5	1.5	0.0514	69
LSRPM 160LR	IP55	52	5500	90	97	95	1.5	1.5	0.0626	79
LSRPM 200L1	IP55	70	5500	122	140	95.2	1.4	1.5	0.13	138
LSRPM 200L1	IP55	85	5500	148	180	95.4	1.4	1.5	0.15	148
LSRPM 200L1	IP55	100	5500	174	210	95.8	1.4	1.5	0.17	153
LSRPM 200L2	IP55	140	5500	243	265	96.6	1.4	1.5	0.22	180

4500  
range

BASED ON INVERTER INPUT VOLTAGE OF 400 V ± 10%  
(in accordance with standard IEC 60034-1)

Type	Index of protection	Rated power	Rated speed	Rated torque	Rated current	Efficiency	(1) Max. torque/ Rated torque	(1) Max. current/ Rated current	Moment of inertia	Weight
		$P_N$ kW	$N_N$ min <sup>-1</sup>	$C_N$ N.m	$I_N$ A	$\eta$ %	$M_M/M_N$	$I_M/I_N$	$J$ kg.m <sup>2</sup>	IM B3 kg
LSRPM 90SL	IP55	6.8	4500	15	12.6	93.5	1.5	1.5	0.0032	14
LSRPM 90L	IP55	8.5	4500	18	15.2	94	1.5	1.5	0.0051	17
LSRPM 100L	IP55	10.2	4500	22	18.8	94	1.5	1.5	0.006	19
LSRPM 100L	IP55	12	4500	25	22	94.5	1.5	1.5	0.0078	24
LSRPM 100L	IP55	13.7	4500	29	25	94.5	1.5	1.5	0.009	26
LSRPM 132M	IP55	18.6	4500	39	35	94.5	1.5	1.5	0.0165	40
LSRPM 132M	IP55	23	4500	49	44	94.5	1.5	1.5	0.0231	44
LSRPM 132M	IP55	27	4500	58	51	95	1.5	1.5	0.0311	49
LSRPM 160MP	IP55	35	4500	75	67	95	1.5	1.5	0.0418	60
LSRPM 160MP	IP55	44	4500	93	81	95.5	1.5	1.5	0.0514	69
LSRPM 160LR	IP55	52	4500	110	97	95.5	1.5	1.5	0.0626	79
LSRPM 200L1	IP55	65	4500	138	130	95.3	1.4	1.5	0.13	138
LSRPM 200L1	IP55	80	4500	170	160	95.7	1.4	1.5	0.15	148
LSRPM 200L1	IP55	100	4500	212	200	96.2	1.4	1.5	0.2	168
LSRPM 200L2	IP55	120	4500	255	230	96.4	1.4	1.5	0.24	185
LSRPM 200LU2	IP55	135	4500	287	270	96.5	1.4	1.5	0.26	195
LSRPM 225SR2	IP55	150	4500	318	277	96.6	1.4	1.5	0.32	225
LSRPM 250SE	IP55	170	4500	361	310	96.5	1.4	1.5	0.76	310

(1) Risk of demagnetisation above these values.

# Permanent magnet synchronous motors

## LSRPM - PLSRPM

### Electrical characteristics

#### C1 - Characteristic data

3600  
range

BASED ON INVERTER INPUT VOLTAGE OF 400 V ± 10%  
(in accordance with standard IEC 60034-1)

Type	Index of protection	Rated power	Rated speed	Rated torque	Rated current	Efficiency	(1) Max. torque/ Rated torque	(1) Max. current/ Rated current	Moment of inertia	Weight
		$P_N$ kW	$N_N$ min <sup>-1</sup>	$C_N$ N.m	$I_N$ A	$\eta$ %	$M_M/M_N$	$I_M/I_N$	$J$ kg.m <sup>2</sup>	IM B3 kg
LSRPM 90SL	IP55	6.4	3600	17	11.9	93	1.5	1.5	0.0032	14
LSRPM 90L	IP55	8	3600	21	14.8	93.5	1.5	1.5	0.0051	17
LSRPM 100L	IP55	9.6	3600	26	17.6	94	1.5	1.5	0.006	19
LSRPM 100L	IP55	11.2	3600	30	21	94	1.5	1.5	0.0078	24
LSRPM 100L	IP55	12.8	3600	34	23	94.5	1.5	1.5	0.009	26
LSRPM 132M	IP55	17.6	3600	47	33	94.5	1.5	1.5	0.0165	40
LSRPM 132M	IP55	22	3600	58	39	94.5	1.5	1.5	0.0231	44
LSRPM 132M	IP55	26	3600	69	48	95	1.5	1.5	0.0311	49
LSRPM 160MP	IP55	34	3600	89	63	95	1.5	1.5	0.0418	60
LSRPM 160MP	IP55	41	3600	110	77	95.5	1.5	1.5	0.0514	69
LSRPM 160LR	IP55	49	3600	130	91	95.5	1.5	1.5	0.0626	79
LSRPM 200L	IP55	50	3600	133	110	95.5	1.35	1.45	0.13	135
LSRPM 200L1	IP55	70	3600	186	140	96	1.35	1.45	0.17	153
LSRPM 200L1	IP55	85	3600	225	157	96.4	1.35	1.45	0.22	178
LSRPM 200LU2	IP55	115	3600	305	220	96.8	1.35	1.45	0.26	195
LSRPM 225SG	IP55	132	3600	350	250	96.8	1.35	1.45	0.54	250
LSRPM 250SE1	IP55	165	3600	438	330	96.9	1.35	1.45	0.57	268
LSRPM 250SE1	IP55	190	3600	504	350	97.1	1.35	1.45	0.65	288
LSRPM 280SD1	IP55	240	3600	637	430	97.1	1.35	1.45	1	383
LSRPM 280MK1	IP55	270	3600	716	480	97.2	1.35	1.45	2.1	620
PLSRPM 315LD	IP23	325	3600	862	575	97.3	1.35	1.45	1.97	735
PLSRPM 315LD	IP23	350	3600	928	660	97.4	1.35	1.45	1.97	760
PLSRPM 315LD	IP23	390	3600	1035	715	97.5	1.35	1.45	1.97	800

3000  
range

BASED ON INVERTER INPUT VOLTAGE OF 400 V ± 10%  
(in accordance with standard IEC 60034-1)

Type	Index of protection	Rated power	Rated speed	Rated torque	Rated current	Efficiency	(1) Max. torque/ Rated torque	(1) Max. current/ Rated current	Moment of inertia	Weight
		$P_N$ kW	$N_N$ min <sup>-1</sup>	$C_N$ N.m	$I_N$ A	$\eta$ %	$M_M/M_N$	$I_M/I_N$	$J$ kg.m <sup>2</sup>	IM B3 kg
LSRPM 90SL	IP55	5.8	3000	19	11	91.5	1.5	1.5	0.0032	14
LSRPM 90L	IP55	7.3	3000	23	13.5	93	1.5	1.5	0.0051	17
LSRPM 100L	IP55	8.7	3000	28	16.2	93	1.5	1.5	0.006	19
LSRPM 100L	IP55	10.2	3000	32	18.8	93.5	1.5	1.5	0.0078	24
LSRPM 100L	IP55	11.6	3000	37	21	93.5	1.5	1.5	0.009	26
LSRPM 132M	IP55	15.8	3000	50	30	93	1.5	1.5	0.0165	40
LSRPM 132M	IP55	19.7	3000	63	38	93.5	1.5	1.5	0.0231	44
LSRPM 132M	IP55	23	3000	74	44	94	1.5	1.5	0.0311	49
LSRPM 160MP	IP55	30	3000	96	57	94.5	1.5	1.5	0.0418	60
LSRPM 160MP	IP55	37	3000	118	68	95	1.5	1.5	0.0514	69
LSRPM 160LR	IP55	44	3000	140	82	95	1.5	1.5	0.0626	79
LSRPM 200L	IP55	50	3000	159	112	95.5	1.35	1.45	0.13	135
LSRPM 200L1	IP55	65	3000	207	126	96	1.35	1.45	0.17	153
LSRPM 200L1	IP55	85	3000	271	164	96.5	1.35	1.45	0.22	178
LSRPM 225ST2	IP55	110	3000	350	215	96.6	1.35	1.45	0.26	195
LSRPM 250SE	IP55	145	3000	462	285	97.1	1.35	1.45	0.57	265
LSRPM 250ME1	IP55	170	3000	541	338	97.2	1.35	1.45	0.65	288
LSRPM 280SC1	IP55	200	3000	637	365	97.3	1.35	1.45	0.84	333
LSRPM 280SD1	IP55	220	3000	700	400	97.4	1.35	1.45	1	383
LSRPM 280MK1	IP55	260	3000	828	470	97.4	1.35	1.45	2.1	620
LSRPM 280MK1	IP55	290	3000	923	530	97.4	1.35	1.45	2.1	620
LSRPM 315SP1	IP55	320	3000	1019	590	97.5	1.35	1.45	2.5	670
PLSRPM315LD	IP23	340	3000	1082	630	97.5	1.35	1.45	4.43	800

(1) Risk of demagnetisation above these values.

# Permanent magnet synchronous motors

## LSRPM - PLSRPM

### Electrical characteristics

## C1 - Characteristic data

2400  
range

BASED ON INVERTER INPUT VOLTAGE OF 400 V ± 10%  
(in accordance with standard IEC 60034-1)

Type	Index of protection	Rated power	Rated speed	Rated torque	Rated current	Efficiency	(1) Max. torque/ Rated torque	(1) Max. current/ Rated current	Moment of inertia	Weight
		$P_N$ kW	$N_N$ min <sup>-1</sup>	$C_N$ N.m	$I_N$ A	$\eta$ %	$M_M/M_N$	$I_M/I_N$	$J$ kg.m <sup>2</sup>	IM B3 kg
LSRPM 90SL	IP55	4.8	2400	19	9.1	90.5	1.5	1.5	0.0032	14
LSRPM 90L	IP55	6	2400	24	10.9	91.5	1.5	1.5	0.0051	17
LSRPM 100L	IP55	7.2	2400	29	13.4	92	1.5	1.5	0.006	19
LSRPM 100L	IP55	8.4	2400	33	15.2	92.5	1.5	1.5	0.0078	24
LSRPM 100L	IP55	9.5	2400	38	17.7	93	1.5	1.5	0.009	26
LSRPM 132M	IP55	13.1	2400	52	25	92.5	1.5	1.5	0.0165	40
LSRPM 132M	IP55	16.3	2400	65	31	93	1.5	1.5	0.0231	44
LSRPM 132M	IP55	19.2	2400	76	37	93.5	1.5	1.5	0.0311	49
LSRPM 160MP	IP55	25	2400	99	47	94	1.5	1.5	0.0418	60
LSRPM 160MP	IP55	31	2400	122	58	94.5	1.5	1.5	0.0514	69
LSRPM 160LR	IP55	36	2400	145	69	94.5	1.5	1.5	0.0626	79
LSRPM 200L	IP55	37.5	2400	149	81	95	1.35	1.45	0.13	135
LSRPM 200L	IP55	50	2400	199	110	95.4	1.35	1.45	0.17	150
LSRPM 200L1	IP55	65	2400	259	137	95.9	1.35	1.45	0.2	168
LSRPM 200L1	IP55	80	2400	318	160	96.6	1.35	1.45	0.24	183
LSRPM 225MR1	IP55	100	2400	398	200	96.9	1.35	1.45	0.3	218
LSRPM 250SE	IP55	125	2400	497	235	97.2	1.35	1.45	0.65	285
LSRPM 250ME	IP55	150	2400	597	285	97.3	1.35	1.45	0.75	310
LSRPM 280SD1	IP55	190	2400	756	350	97.5	1.35	1.45	1	383
LSRPM 280MK1	IP55	230	2400	915	429	97.4	1.35	1.45	1.9	591
LSRPM 315SP1	IP55	285	2400	1134	509	97.6	1.35	1.45	2.5	675
LSRPM 315SR1	IP55	310	2400	1233	565	97.7	1.35	1.45	2.6	715
LSRPM 315MR1	IP55	350	2400	1393	645	97.5	1.35	1.45	2.7	720

1800  
range

BASED ON INVERTER INPUT VOLTAGE OF 400 V ± 10%  
(in accordance with standard IEC 60034-1)

Type	Index of protection	Rated power	Rated speed	Rated torque	Rated current	Efficiency	(1) Max. torque/ Rated torque	(1) Max. current/ Rated current	Moment of inertia	Weight
		$P_N$ kW	$N_N$ min <sup>-1</sup>	$C_N$ N.m	$I_N$ A	$\eta$ %	$M_M/M_N$	$I_M/I_N$	$J$ kg.m <sup>2</sup>	IM B3 kg
LSRPM 90SL	IP55	3.6	1800	19	6.9	89	1.5	1.5	0.0032	14
LSRPM 90L	IP55	4.5	1800	24	8.5	90.5	1.5	1.5	0.0051	17
LSRPM 100L	IP55	5.4	1800	29	10.2	91	1.5	1.5	0.006	19
LSRPM 100L	IP55	6.3	1800	33	11.8	91.5	1.5	1.5	0.0078	24
LSRPM 100L	IP55	7.2	1800	38	13.4	92	1.5	1.5	0.009	26
LSRPM 132M	IP55	9.8	1800	52	19	92	1.5	1.5	0.0165	40
LSRPM 132M	IP55	12.3	1800	65	24	92.5	1.5	1.5	0.0231	44
LSRPM 132M	IP55	14.4	1800	76	28	93	1.5	1.5	0.0311	49
LSRPM 160MP	IP55	18.7	1800	99	36	93.5	1.5	1.5	0.0418	60
LSRPM 160MP	IP55	23	1800	122	43	94	1.5	1.5	0.0514	69
LSRPM 160LR	IP55	27.3	1800	145	52	94	1.5	1.5	0.0626	79
LSRPM 200L	IP55	33	1800	175	79	94	1.35	1.45	0.13	135
LSRPM 200L	IP55	40	1800	212	82.5	94.8	1.35	1.45	0.17	150
LSRPM 200L	IP55	55	1800	292	115	95.7	1.35	1.45	0.2	165
LSRPM 225ST1	IP55	70	1800	371	143	96.1	1.35	1.45	0.26	193
LSRPM 225MR1	IP55	85	1800	451	172	96	1.35	1.45	0.32	223
LSRPM 250ME	IP55	100	1800	531	204	96.1	1.35	1.45	0.65	285
LSRPM 280SC	IP55	125	1800	663	248	96.3	1.35	1.45	0.84	330
LSRPM 280SD	IP55	150	1800	796	295	96.4	1.35	1.45	1	380
LSRPM 280MK1	IP55	175	1800	928	330	96.5	1.35	1.45	1.8	568
LSRPM 315SP1	IP55	195	1800	1035	370	96.7	1.35	1.45	2.24	635
LSRPM 315MR1	IP55	230	1800	1220	425	96.9	1.35	1.45	2.7	720

(1) Risk of demagnetisation above these values.

# Permanent magnet synchronous motors

## LSRPM - PLSRPM

### Electrical characteristics

#### C1 - Characteristic data

1500  
range

BASED ON INVERTER INPUT VOLTAGE OF 400 V ± 10%  
(in accordance with standard IEC 60034-1)

Type	Index of protection	Rated power	Rated speed	Rated torque	Rated current	Efficiency	(1) Max. torque/ Rated torque	(1) Max. current/ Rated current	Moment of inertia	Weight
		$P_N$ kW	$N_N$ min <sup>-1</sup>	$C_N$ N.m	$I_N$ A	$\eta$ %	$M_M/M_N$	$I_M/I_N$	$J$ kg.m <sup>2</sup>	IM B3 kg
LSRPM 90SL	IP55	3	1500	19	5.9	87	1.5	1.5	0.0032	14
LSRPM 90L	IP55	3.7	1500	24	7.2	89	1.5	1.5	0.0051	17
LSRPM 100L	IP55	4.5	1500	29	8.6	90	1.5	1.5	0.006	19
LSRPM 100L	IP55	5.2	1500	33	9.9	91	1.5	1.5	0.0078	24
LSRPM 100L	IP55	6	1500	38	10.9	91.5	1.5	1.5	0.009	26
LSRPM 132M	IP55	8.2	1500	52	16	91	1.5	1.5	0.0165	40
LSRPM 132M	IP55	10.2	1500	65	19.9	91.5	1.5	1.5	0.0231	44
LSRPM 132M	IP55	12	1500	76	23	92	1.5	1.5	0.0311	49
LSRPM 160MP	IP55	15.6	1500	99	30	92.5	1.5	1.5	0.0418	60
LSRPM 160MP	IP55	19.2	1500	122	37	93	1.5	1.5	0.0514	69
LSRPM 160LR	IP55	22.8	1500	145	43	93.5	1.5	1.5	0.0626	79
LSRPM 200L	IP55	25	1500	159	56	94	1.35	1.45	0.13	135
LSRPM 200L	IP55	33	1500	210	75	94.6	1.35	1.45	0.17	150
LSRPM 200L	IP55	40	1500	255	83	95.2	1.35	1.45	0.2	165
LSRPM 200LU	IP55	55	1500	350	110	95.5	1.35	1.45	0.26	190
LSRPM 225MR1	IP55	70	1500	446	142	95.7	1.35	1.45	0.32	223
LSRPM 250ME	IP55	85	1500	541	175	95.6	1.35	1.45	0.65	285
LSRPM 280SC	IP55	105	1500	668	215	96.3	1.35	1.45	0.84	330
LSRPM 280SD	IP55	125	1500	796	245	96.4	1.35	1.45	1	380
LSRPM 280MK1	IP55	145	1500	923	285	96.3	1.35	1.45	1.8	568
LSRPM 315SP1	IP55	175	1500	1114	350	96.5	1.35	1.45	2.24	635
LSRPM 315MR1	IP55	220	1500	1401	430	96.7	1.35	1.45	2.7	720

900  
range

BASED ON INVERTER INPUT VOLTAGE OF 400 V ± 10%  
(in accordance with standard IEC 60034-1)

Type	Index of protection	Rated power	Rated speed	Rated torque	Rated current	Efficiency	(1) Max. torque/ Rated torque	(1) Max. current/ Rated current	Moment of inertia	Weight
		$P_N$ kW	$N_N$ min <sup>-1</sup>	$C_N$ N.m	$I_N$ A	$\eta$ %	$M_M/M_N$	$I_M/I_N$	$J$ kg.m <sup>2</sup>	IM B3 kg
LSRPM 90SL	IP55	1.8	900	19	3.8	82	1.5	1.5	0.0032	14
LSRPM 90L	IP55	2.2	900	24	4.6	84	1.5	1.5	0.0051	17
LSRPM 100L	IP55	2.7	900	29	5.4	85	1.5	1.5	0.006	19
LSRPM 100L	IP55	3.1	900	33	6.2	87	1.5	1.5	0.0078	24
LSRPM 100L	IP55	3.6	900	38	6.9	88	1.5	1.5	0.009	26
LSRPM 132M	IP55	4.9	900	52	9.9	88	1.5	1.5	0.0165	40
LSRPM 132M	IP55	6.1	900	65	12.3	89	1.5	1.5	0.0231	44
LSRPM 132M	IP55	7.2	900	76	14.3	90	1.5	1.5	0.0311	49
LSRPM 160MP	IP55	9.4	900	99	18.4	90.5	1.5	1.5	0.0418	60
LSRPM 160MP	IP55	11.5	900	122	23	91	1.5	1.5	0.0514	69
LSRPM 160LR	IP55	13.7	900	145	27	91	1.5	1.5	0.0626	79
LSRPM 200L	IP55	15	900	159	38	90.6	1.35	1.45	0.13	135
LSRPM 200L	IP55	20	900	212	43	91.6	1.35	1.45	0.17	150
LSRPM 200L	IP55	25	900	265	52	92.3	1.35	1.45	0.2	165
LSRPM 200LU	IP55	33	900	350	70	92.9	1.35	1.45	0.26	190
LSRPM 250SE	IP55	40	900	424	79	95.5	1.35	1.45	0.54	250
LSRPM 250ME	IP55	50	900	531	98	95.8	1.35	1.45	0.65	285
LSRPM 280SD	IP55	60	900	637	120	96.2	1.35	1.45	0.92	350
LSRPM 280SD	IP55	75	900	796	140	96	1.35	1.45	1	380
LSRPM 280MK1	IP55	85	900	902	170	95.9	1.35	1.45	1.67	545
LSRPM 315SP1	IP55	100	900	1061	190	96.2	1.35	1.45	2.1	625
LSRPM 315MR1	IP55	130	900	1379	275	96.6	1.35	1.45	2.6	715

(1) Risk of demagnetisation above these values.

# Permanent magnet synchronous motors

## LSRPM - PLSRPM

### Electrical characteristics

#### C1 - Characteristic data

750  
range

BASED ON INVERTER INPUT VOLTAGE OF 400 V ± 10%  
(in accordance with standard IEC 60034-1)

Type	Index of protection	Rated power	Rated speed	Rated torque	Rated current	Efficiency	(1) Max. torque/ Rated torque	(1) Max. current/ Rated current	Moment of inertia	Weight
		$P_N$ kW	$N_N$ min <sup>-1</sup>	$C_N$ N.m	$I_N$ A	$\eta$ %	$M_M/M_N$	$I_M/I_N$	$J$ kg.m <sup>2</sup>	IM B3 kg
LSRPM 90SL	IP55	1.4	750	18	3	80	1.5	1.5	0.0032	14
LSRPM 90L	IP55	1.8	750	23	3.7	83	1.5	1.5	0.0051	17
LSRPM 100L	IP55	2.1	750	27	4.4	84	1.5	1.5	0.0066	19
LSRPM 100L	IP55	2.5	750	32	5	85	1.5	1.5	0.0078	24
LSRPM 100L	IP55	2.8	750	36	5.7	86	1.5	1.5	0.009	26
LSRPM 132M	IP55	4.1	750	52	8.5	86	1.5	1.5	0.0165	40
LSRPM 132M	IP55	5.1	750	65	10.5	87	1.5	1.5	0.0231	44
LSRPM 132M	IP55	6	750	76	12.2	88	1.5	1.5	0.0311	49
LSRPM 160MP	IP55	7.8	750	99	15.6	89	1.5	1.5	0.0418	60
LSRPM 160MP	IP55	9.6	750	122	19	90	1.5	1.5	0.0514	69
LSRPM 160LR	IP55	10.8	750	138	21	90.5	1.5	1.5	0.0626	79
LSRPM 200L	IP55	12.5	750	159	32	89.5	1.35	1.45	0.13	135
LSRPM 200L	IP55	16	750	204	35	90.8	1.35	1.45	0.17	150
LSRPM 200L	IP55	21	750	267	44	91.4	1.35	1.45	0.2	165
LSRPM 200LU	IP55	26	750	337	57	92.2	1.35	1.45	0.26	190
LSRPM 250SE	IP55	33	750	420	65	94.8	1.35	1.45	0.54	250
LSRPM 250SE	IP55	40	750	509	80	95.3	1.35	1.45	0.65	285
LSRPM 280SD	IP55	55	750	700	107	95.5	1.35	1.45	0.92	350
LSRPM 280MD	IP55	70	750	891	142	95.6	1.35	1.45	1	380
LSRPM 315SP1	IP55	85	750	1082	171	95.9	1.35	1.45	2.1	625
LSRPM 315MR1	IP55	110	750	1401	215	96.3	1.35	1.45	2.6	715

375  
range

BASED ON INVERTER INPUT VOLTAGE OF 400 V ± 10%  
(in accordance with standard IEC 60034-1)

Type	Index of protection	Rated power	Rated speed	Rated torque	Rated current	Efficiency	(1) Max. torque/ Rated torque	(1) Max. current/ Rated current	Moment of inertia	Weight
		$P_N$ kW	$N_N$ min <sup>-1</sup>	$C_N$ N.m	$I_N$ A	$\eta$ %	$M_M/M_N$	$I_M/I_N$	$J$ kg.m <sup>2</sup>	IM B3 kg
LSRPM 90SL	IP55	0.7	375	17	1.6	70	1.5	1.5	0.0032	14
LSRPM 90L	IP55	0.8	375	21	1.9	74	1.5	1.5	0.0051	17
LSRPM 100L	IP55	1.0	375	26	2.3	75	1.5	1.5	0.006	19
LSRPM 100L	IP55	1.2	375	30	2.6	77	1.5	1.5	0.0078	24
LSRPM 100L	IP55	1.3	375	34	3	78	1.5	1.5	0.009	26
LSRPM 132M	IP55	1.8	375	47	4.2	78	1.5	1.5	0.0165	40
LSRPM 132M	IP55	2.3	375	58	5.1	80	1.5	1.5	0.0231	44
LSRPM 132M	IP55	2.7	375	69	5.8	82	1.5	1.5	0.0311	49
LSRPM 160MP	IP55	3.5	375	89	7.4	84	1.5	1.5	0.0418	60
LSRPM 160MP	IP55	4.3	375	110	9	85	1.5	1.5	0.0514	69
LSRPM 160LR	IP55	5.1	375	130	10.6	86	1.5	1.5	0.0626	79

(1) Risk of demagnetisation above these values.

# Permanent magnet synchronous motors LSRPM - PLSRPM Dimensions

	PAGE
D1 - Shaft extensions	40
D2 - Foot mounting IM B3 (IM 1001)	41
D3 - Foot and flange mounted IM B35 (IM 2001)	42
D4 - Flange mounted IM B5 (IM 3001)	43
D5 - Foot and face mounted IM B34 (IM 2101)	44
D6 - Face mounted IM B14 (IM 3601)	45
D7 - Motor with options	46

# Permanent magnet synchronous motors LSRPM - PLSRPM Dimensions

## D1 - Shaft extensions

Dimensions in millimetres

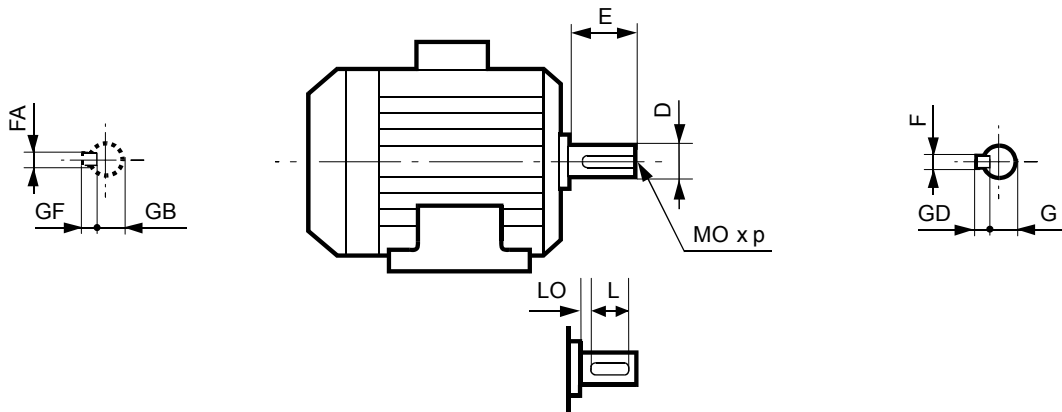

Type	Main shaft extensions								
	F	GD	D	G	E	O	p	L	LO
LSRPM 90 SL/L	8	7	28j6	24	60	10	22	50	6
LSRPM 100 L	10	8	32k6	27	80	12	28	63	8.5
LSRPM 132 M	10	8	38k6	33	80	12	28	63	7
LSRPM 160 MP/LR	14	9	48k6	42.5	110	16	36	98	6
LSRPM 200 L/L1/L2/LU/LU2	16	10	55m6	49	110	20	42	97	13
LSRPM 225 ST1/ST2/SR2/SG/MR	18	11	60m6	53	140	20	42	126	14
LSRPM 250 SE/SE1/ME/ME1	18	11	65m6	58	140	20	42	126	14
LSRPM 280 SC/SC1/SD/SD1	20	12	70m6	62.5	140	20	42	125	15
LSRPM 280 MD/MK1	20	12	75m6	67.5	140	20	42	125	15
LSRPM 315 SP1	22	14	80m6	71	170	20	42	155	15
LSRPM 315 MP1/SR1	22	14	85m6	76	170	20	42	155	15
PLSRPM 315 LD	22	14	80m6	71	170	20	42	155	15

# Permanent magnet synchronous motors LSRPM - PLSRPM Dimensions

## D2 - Foot mounted IM B3 (IM 1001)

Dimensions in millimetres

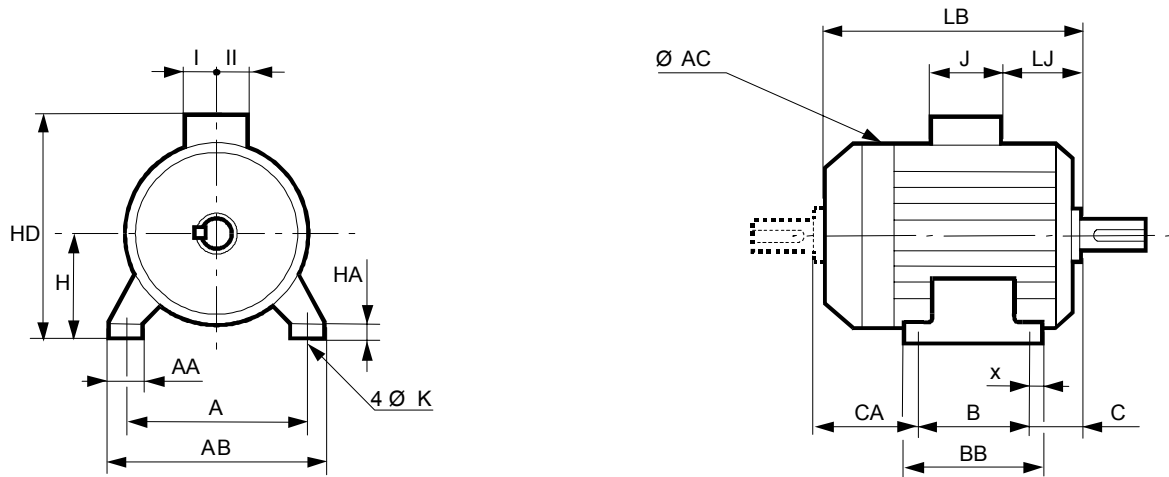

Type	Main dimensions																	
	A	AB	B	BB	C	X	AA	K	HA	H	AC	HD	LB	LJ	J	I	II	CA
LSRPM 90 SL	140	172	100	166	56	29	39	10	11	90	200	245	245	14	160	55	55	66
LSRPM 90 L	140	172	125	166	56	29	39	10	11	90	200	245	245	14	160	55	55	68
LSRPM 100 L	160	196	140	167	63	13	40	13	13	100	200	260	290	15	160	55	55	93
LSRPM 132 M	216	250	178	211	89	16	50	12	15	132	280	341	385	23	194	79	78	126
LSRPM 160 MP	254	294	254	298	108	22	64	14	25	160	310	387	468	42	186	112	98	154
LSRPM 160 LR	254	294	254	298	108	22	64	14	25	160	310	387	495	42	186	112	98	138
LSRPM 200 L	318	388	305	375	133	35	103	18.5	36	200	390	476	621	77	186	112	98	194
LSRPM 200 L1	318	388	305	375	133	35	103	18.5	36	200	390	510	621	55	231	119	141	194
LSRPM 200 L2	318	388	305	375	133	35	103	18.5	36	200	390	571	621	59	292	148	180	194
LSRPM 200 LU	318	388	305	375	133	35	103	18.5	36	200	390	476	669	77	186	112	98	244
LSRPM 200 LU2	318	388	305	375	133	35	103	18.5	36	200	390	571	669	59	292	148	180	244
LSRPM 225 ST1	356	431	286	386	149	50	127	18.5	36	225	390	535	627	62	231	119	141	203
LSRPM 225 ST2	356	431	286	386	149	50	127	18.5	36	225	390	596	627	62	292	148	180	203
LSRPM 225 SR2	356	431	286	386	149	50	127	18.5	36	225	390	596	676	66	292	148	180	253
LSRPM 225 SG	356	420	286	375	149	30	65	18.5	30	225	479	629	810	68	292	148	180	360
LSRPM 225 MR1	356	431	311	386	149	50	127	18.5	36	225	390	535	676	68	231	119	141	253
LSRPM 250 SE	406	470	311	420	168	35	90	24	36	250	479	655	810	68	292	148	180	341
LSRPM 250 SE1	406	470	311	420	168	35	90	24	36	250	479	744	810	4	420	180	235	341
LSRPM 250 ME	406	470	349	420	168	35	90	24	36	250	479	655	810	68	292	148	180	303
LSRPM 250 ME1	406	470	349	420	168	35	90	24	36	250	479	744	810	4	420	180	235	303
LSRPM 280 SC	457	520	368	478	190	35	90	24	35	280	479	685	810	68	292	148	180	262
LSRPM 280 SC1	457	520	368	478	190	35	90	24	35	280	479	774	810	4	420	180	235	262
LSRPM 280 SD	457	520	368	478	190	35	90	24	35	280	479	685	870	68	292	148	180	322
LSRPM 280 SD1	457	520	368	478	190	35	90	24	35	280	479	774	870	4	420	180	235	322
LSRPM 280 MD	457	520	419	478	190	35	90	24	35	280	479	685	870	68	292	148	180	271
LSRPM 280 MK1	457	520	419	495	190	40	85	24	35	280	586	834	921	35	420	180	235	328
LSRPM 315 SP1	508	594	406	537	216	40	114	28	70	315	586	870	947	61	420	180	235	341
LSRPM 315 SR1	508	594	406	537	216	40	114	28	70	315	586	870	1017	61	420	180	235	360
LSRPM 315 MR1	508	594	457	537	216	40	114	28	70	315	586	870	1017	61	420	180	235	360
PLSRPM 315 LD	508	608	508	588	216	40	100	28	26	315	680	865	1085	241	420	180	235	374

# Permanent magnet synchronous motors LSRPM - PLSRPM Dimensions

## D3 - Foot and flange mounted IM B35 (IM 2001)

Dimensions in millimetres

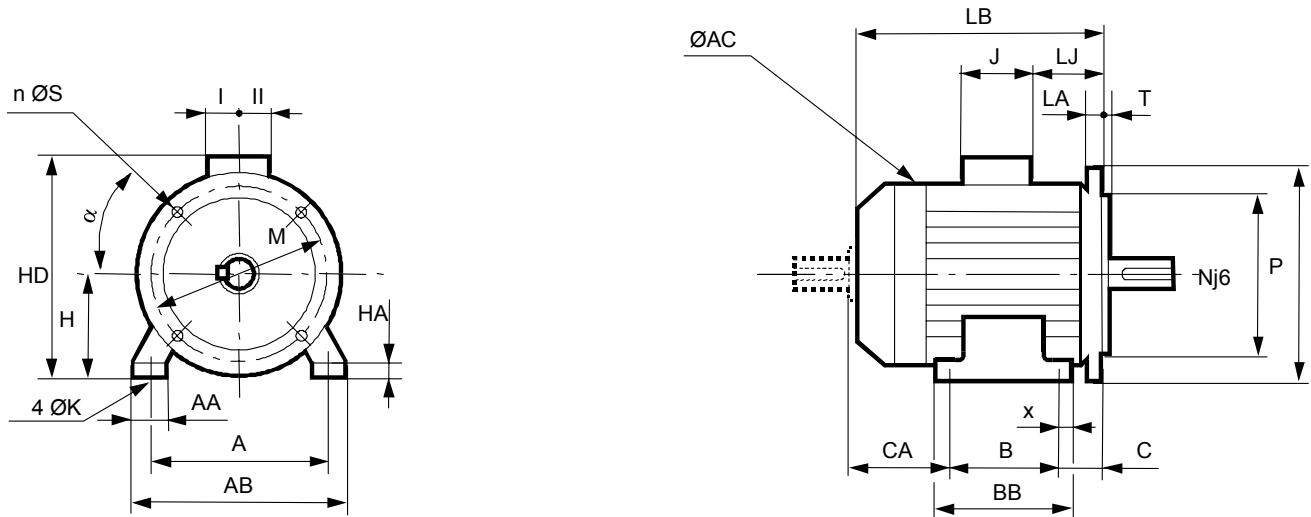

Type	Main dimensions																		
	A	AB	B	BB	C	X	AA	K	HA	H	AC	HD	LB	LJ	J	I	II	CA	Sym.
LSRPM 90 SL	140	172	100	166	56	29	39	10	11	90	200	245	245	14	160	55	55	66	FF165
LSRPM 90 L	140	172	125	166	56	29	39	10	11	90	200	245	245	14	160	55	55	68	FF165
LSRPM 100 L	160	196	140	167	63	13	40	13	13	100	200	260	290	15	160	55	55	93	FF215
LSRPM 132 M	216	250	178	211	89	16	50	12	15	132	280	341	385	23	194	79	78	126	FF265
LSRPM 160 MP	254	294	254	298	108	22	64	14	25	160	310	387	468	42	186	112	74	154	FF300
LSRPM 160 LR	254	294	254	298	108	22	64	14	25	160	310	387	495	42	186	112	74	138	FF300
LSRPM 200 L	318	388	305	375	133	35	103	18.5	36	200	390	476	621	77	186	112	98	194	FF350
LSRPM 200 L1	318	388	305	375	133	35	103	18.5	36	200	390	510	621	55	231	119	141	194	FF350
LSRPM 200 L2	318	388	305	375	133	35	103	18.5	36	200	390	571	621	59	292	148	180	194	FF350
LSRPM 200 LU	318	388	305	375	133	35	103	18.5	36	200	390	476	669	77	186	112	98	244	FF350
LSRPM 200 LU2	318	388	305	375	133	35	103	18.5	36	200	390	571	669	59	292	148	180	244	FF350
LSRPM 225 ST1	356	431	286	386	149	50	127	18.5	36	225	390	535	627	62	231	119	141	203	FF400
LSRPM 225 ST2	356	431	286	386	149	50	127	18.5	36	225	390	596	627	62	292	148	180	203	FF400
LSRPM 225 SR2	356	431	286	386	149	50	127	18.5	36	225	390	596	676	66	292	148	180	253	FF400
LSRPM 225 SG	356	420	286	375	149	50	65	18.5	30	225	479	629	810	68	292	148	180	360	FF400
LSRPM 225 MR1	356	431	311	386	149	50	127	18.5	36	225	390	535	676	68	231	119	141	253	FF400
LSRPM 250 SE	406	470	311	420	168	35	90	24	36	250	479	655	810	68	292	148	180	341	FF500
LSRPM 250 SE1	406	470	311	420	168	35	90	24	36	250	479	744	810	4	420	180	235	341	FF500
LSRPM 250 ME	406	470	349	420	168	35	90	24	36	250	479	655	810	68	292	148	180	303	FF500
LSRPM 250 ME1	406	470	349	420	168	35	90	24	36	250	479	744	810	4	420	180	235	303	FF500
LSRPM 280 SC	457	520	368	478	190	35	90	24	35	280	479	685	810	68	292	148	180	262	FF500
LSRPM 280 SC1	457	520	368	478	190	35	90	24	35	280	479	774	810	4	420	180	235	262	FF500
LSRPM 280 SD	457	520	368	478	190	35	90	24	35	280	479	685	870	68	292	148	180	322	FF500
LSRPM 280 SD1	457	520	368	478	190	35	90	24	35	280	479	774	870	4	420	180	235	322	FF500
LSRPM 280 MD	457	520	419	478	190	35	90	24	35	280	479	685	870	68	292	148	180	271	FF500
LSRPM 280 MK1	457	520	419	495	190	40	85	24	35	280	586	834	921	35	420	180	235	328	FF500
LSRPM 315 SP1	508	594	406	537	216	40	114	28	70	315	586	781	947	61	420	180	235	341	FF600
LSRPM 315 SR1	508	594	406	537	216	40	114	28	70	315	586	781	1017	61	420	180	235	360	FF600
LSRPM 315 MR1	508	594	457	537	216	40	114	28	70	315	586	781	1017	61	420	180	235	360	FF600
PLSRPM 315 LD	508	608	508	588	216	40	100	28	26	315	680	865	1164*	241	420	180	235	374	FF740

\* dimension with encoder

# Permanent magnet synchronous motors LSRPM - PLSRPM Dimensions

## D4 - Flange mounted IM B5 (IM 3001)\* IM V1 (IM 3011)

Dimensions in millimetres

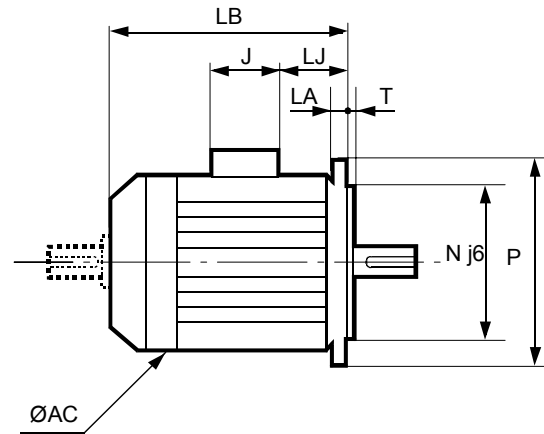
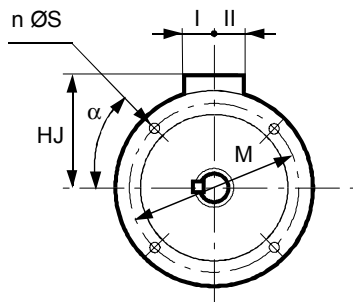

IEC symbol	Flange dimensions								
	M	N	P	T	n	α	S	LA	
FF165	165	130	200	3.5	4	45	12	10	
FF165	165	130	200	3.5	4	45	12	10	
FF215	215	180	250	4	4	45	14.5	12	
FF265	265	230	300	4	4	45	14.5	14	
FF300	300	250	350	5	4	45	18.5	14	
FF300	300	250	350	5	4	45	18.5	14	
FF350	350	300	400	5	4	45	18.5	15	
FF350	350	300	400	5	4	45	18.5	15	
FF350	350	300	400	5	4	45	18.5	15	
FF350	350	300	400	5	4	45	18.5	15	
FF350	350	300	400	5	4	45	18.5	15	
FF400	400	350	450	5	8	22.5	18.5	15	
FF400	400	350	450	5	8	22.5	18.5	15	
FF400	400	350	450	5	8	22.5	18.5	15	
FF400	400	350	450	5	8	22.5	18.5	15	
FF400	400	350	450	5	8	22.5	18.5	15	
FF500	500	450	550	5	8	22.5	18.5	22	
FF500	500	450	550	5	8	22.5	18.5	22	
FF500	500	450	550	5	8	22.5	18.5	22	
FF500	500	450	550	5	8	22.5	18.5	22	
FF500	500	450	550	5	8	22.5	18.5	22	
FF500	500	450	550	5	8	22.5	18.5	22	
FF500	500	450	550	5	8	22.5	18.5	22	
FF500	500	450	550	5	8	22.5	18.5	22	
FF600	600	550	660	6	8	22.5	24	22	
FF600	600	550	660	6	8	22.5	24	22	
FF600	600	550	660	6	8	22.5	24	22	

Type	Main dimensions						
	AC	LB	HJ	LJ	J	I	II
LSRPM 90 SL	200	245	155	14	160	55	55
LSRPM 90 L	200	245	155	14	160	55	55
LSRPM 100 L	200	290	160	15	160	55	55
LSRPM 132 M	264	385	209	23	194	79	78
LSRPM 160 MP	264	468	227	42	186	112	98
LSRPM 160 LR	264	495	227	42	186	112	98
LSRPM 200 L	390	621	276	77	186	112	98
LSRPM 200 L1	390	621	310	55	231	119	141
LSRPM 200 L2	390	621	371	59	292	148	180
LSRPM 200 LU	390	669	276	77	186	112	98
LSRPM 200 LU2	390	669	371	59	292	148	180
LSRPM 225 ST1	390	627	310	61.5	231	119	141
LSRPM 225 ST2	390	627	371	-	292	148	180
LSRPM 225 SR2	390	676	371	-	292	148	180
LSRPM 225 SG	479	629	404	68	292	148	180
LSRPM 225 MR1	390	535	276	61.5	231	119	141
LSRPM 250 SE	479	810	405	68	292	148	180
LSRPM 250 SE1	479	810	494	4	420	180	235
LSRPM 250 ME	479	810	405	68	292	148	180
LSRPM 250 ME1	479	810	494	4	420	180	235
LSRPM 280 SC	479	810	405	68	292	148	180
LSRPM 280 SC1	479	810	494	4	420	180	235
LSRPM 280 SD	479	870	405	68	292	148	180
LSRPM 280 SD1	479	870	494	4	420	180	235
LSRPM 280 MD	479	870	405	68	292	148	180
LSRPM 280 MK1	586	921	554	35	420	180	235
LSRPM 315 SP1	586	947	554	61	420	180	235
LSRPM 315 MP1	586	947	554	61	420	180	235
LSRPM 315 SR1	586	1017	554	61	420	180	235

\* for a frame size  $\geq$  à 250 mm for IM 3001 use, please consult Leroy-Somer.  
Dimensions of shaft extensions identical to those for foot mounted motors.

# Permanent magnet synchronous motors LSRPM - PLSRPM Dimensions

## D5 - Foot and face mounting IM B34 (IM 2101)

Dimensions in millimetres

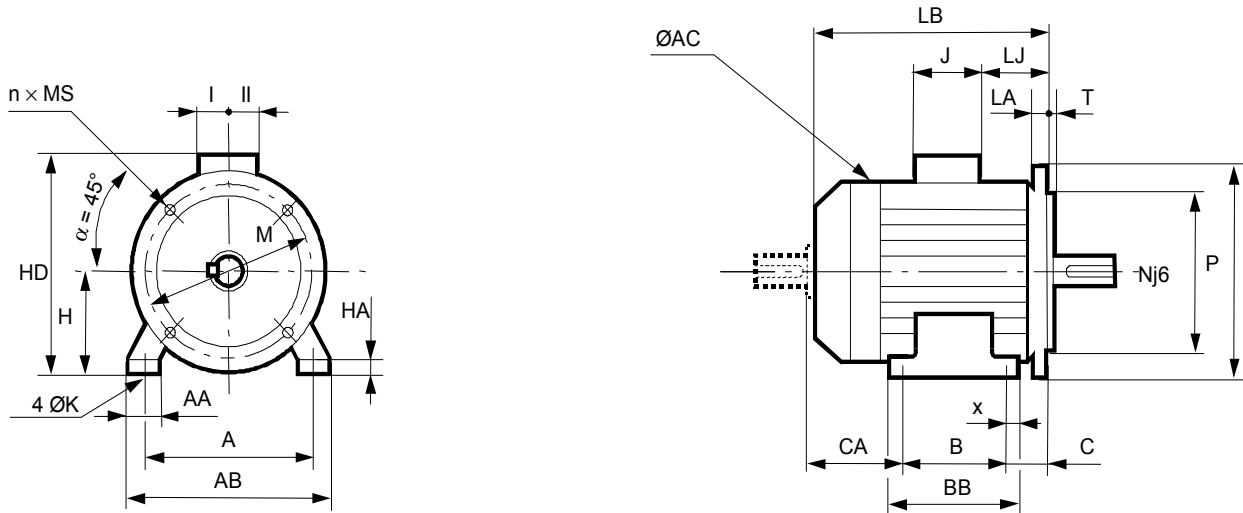

Type	Main dimensions																		
	A	AB	B	BB	C	X	AA	K	HA	H	AC	HD	LB	LJ	J	I	II	CA	Sym.
LSRPM 90 SL	140	172	100	166	56	29	39	10	11	90	200	245	245	14	160	55	55	66	FT115
LSRPM 90 L	140	172	125	166	56	29	39	10	11	90	200	245	245	14	160	55	55	68	FT115
LSRPM 100 L	160	196	140	167	63	13	40	13	13	100	200	260	290	15	160	55	55	93	FT130
LSRPM 132 M	216	250	178	211	89	16	50	12	15	132	264	341	385	23	194	79	78	126	FT215
LSRPM 160 MP	PLEASE CONSULT LEROY-SOMER																		
LSRPM 160 LR	PLEASE CONSULT LEROY-SOMER																		

# Permanent magnet synchronous motors LSRPM - PLSRPM Dimensions

## D6 - Face mounting IM B14 (IM 3601)

Dimensions in millimetres

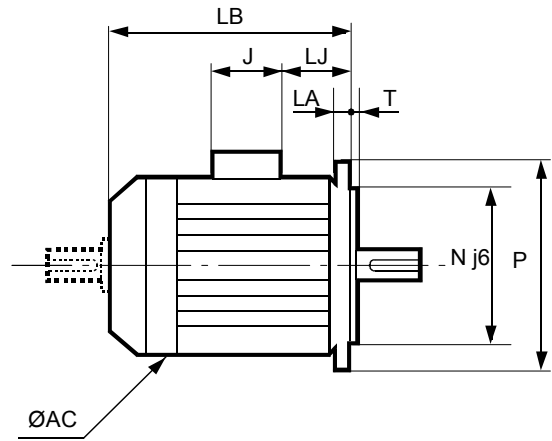
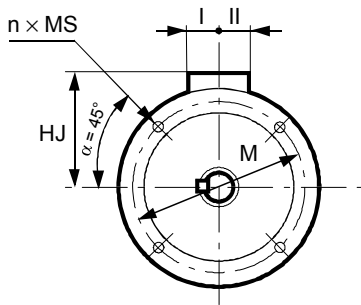

IEC symbol	Flange dimensions					
	M	N	P	T	n	MS
<b>FT115</b>	115	95	140	3	4	M8
<b>FT115</b>	115	95	140	3	4	M8
<b>FT130</b>	130	110	160	3.5	4	M8
<b>FT215</b>	215	180	250	4	4	M12

PLEASE CONSULT LEROY-SOMER

Type	Main dimensions							
	AC	LB	HJ	LJ	J	I	II	CA
<b>LSRPM 90 SL</b>	200	245	155	14	160	55	55	-
<b>LSRPM 90 L</b>	200	245	155	14	160	55	55	-
<b>LSRPM 100 L</b>	200	290	160	15	160	55	55	-
<b>LSRPM 132 M</b>	264	385	209	23	194	79	78	126
<b>LSRPM 160 MP</b>	PLEASE CONSULT LEROY-SOMER							
<b>LSRPM 160 LR</b>	PLEASE CONSULT LEROY-SOMER							

Dimensions of shaft extensions identical to those for foot mounted motors.

# Permanent magnet synchronous motors LSRPM - PLSRPM Dimensions

## D7 - Motor with options

Dimensions in millimetres

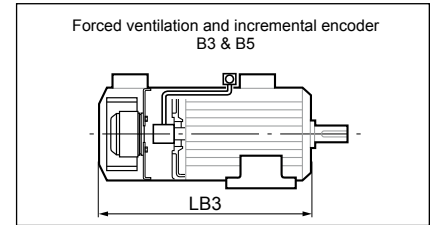
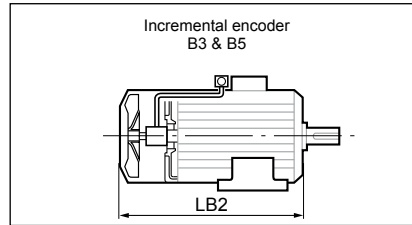
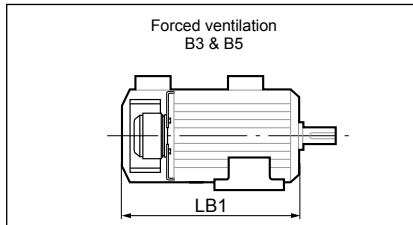

Type	LB <sub>1</sub>	LB <sub>2</sub>	LB <sub>3</sub>
LSRPM 90 SL	338	328	383
LSRPM 90 L	338	328	383
LSRPM 100 L	380	376	431
LSRPM 132 M	462	461	499
LSRPM 160 MP	710	710	710
LSRPM 160 LR	710	575	710
LSRPM 200 L/L1	802	674	802
LSRPM 200 LU/LU1	847	723	847
LSRPM 225 ST/ST1	808	681	808
LSRPM 225 SR/SR1	854	730	854
LSRPM 225 MR	854	730	854
LSRPM 250 SE	1012	860	1012
LSRPM 250 ME	1012	860	1012
LSRPM 280 SC	1012	860	1012
LSRPM 280 SD	1072	920	1072
LSRPM 280 MD	1072	920	1072
LSRPM 280 MK	1075	965	1075
LSRPM 315 SP	1137	991	1075
LSRPM 315 MR/SR	1251	1061	1251
PLSRPM 315 LD	1290	1164	1290

**Nota :** Dimensions of single-turn and multi-turn absolute encoders will be supplied on request.

# Permanent magnet synchronous motors LSRPM - PLSRPM Construction







	PAGE
E1 - Definition of «Index of Protection» (IP/IK)	48
E2 - Components	49
E3 - External finish	50
E4 - Mounting arrangements	51
E5 - Bearings and lubrication	52
E6 - Connection	53
E7 - Machine vibration level	54-55

# Permanent magnet synchronous motors LSRPM - PLSRPM Construction

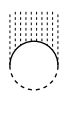
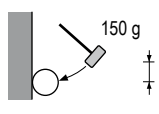
## E1 - Definition of «Index of Protection» (IP/IK)

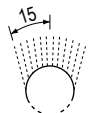
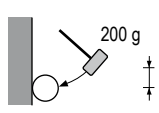
Indices of protection of electrical equipment enclosures  
In accordance with IEC 60034-5 - EN 60034-5 (IP) - EN 50102 (IK)

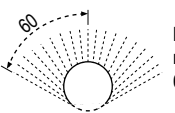
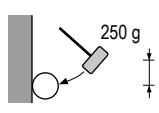
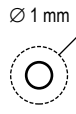
In standard configuration, motors are  
IP 55 / IK 08 for LSRPM and  
IP 23 / IK 08 for PLSRPM

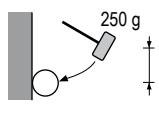
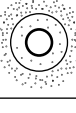
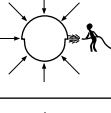
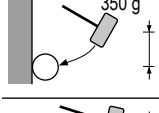
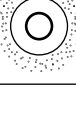
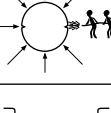
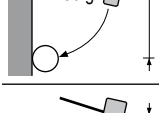
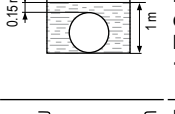
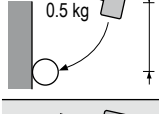
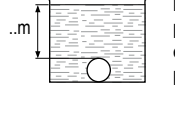
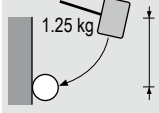
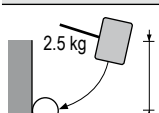
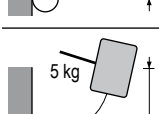
1st number: Protection against solid objects			2nd number: Protection against liquids			3rd number: Mechanical protection		
IP	Tests	Definition	IP	Tests	Definition	IK	Tests	Definition
0		No protection	0		No protection	00		No protection
1		Protected against solid objects larger than 50 mm (e.g. accidental contact with the hand)	1		Protected against water drops falling vertically (condensation)	01		Impact energy: 0.15 J
2		Protected against solid objects larger than 12 mm (e.g. a finger)	2		Protected against water drops falling at up to 15° from the vertical	02		Impact energy: 0.20 J
3		Protected against solid objects larger than 2.5 mm (e.g. tools, wires)	3		Protected against rain falling at up to 60° from the vertical	03		Impact energy: 0.37 J
4		Protected against solid objects larger than 1 mm (e.g. thin tools, small wires)	4		Protected against projected water from all directions	04		Impact energy: 0.50 J
5		Protected against dust (no deposits of harmful material)	5		Protected against jets of water from all directions from a hose	05		Impact energy: 0.70 J
6		Protected against any dust penetration	6		Protected against projected water comparable to big waves	06		Impact energy: 1 J
			7		Protected against effects of immersion between 0.15 and 1 m	07		Impact energy: 2 J
			8		Protected against prolonged effects of immersion under pressure	08		Impact energy: 5 J
						09		Impact energy: 10 J
						10		Impact energy: 20 J

Example :

IP 55 machine

IP : Index of protection

5 : Machine protected against dust and accidental contact.

Test result: **no dust enters** in harmful quantities, no risk of direct contact with rotating parts.  
The test will last for 2 hours (test result: no entry of talc which could affect the correct running of the machine).

5 : Machine protected against jets of water from all directions from hoses at 3 m distance with a flow rate of 12.5 l/min at 0.3 bar.

The test will last for 3 minutes (test result: **no damage from water** projected onto the machine).

# Permanent magnet synchronous motors LSRPM - PLSRPM Construction

## E2 - Components

### Description of motors

Component	Materials	Remarks
Housing	LSRPM : Aluminium alloy PLSRPM : Steel	<ul style="list-style-type: none"> <li>- with integral or screw-on feet, or without feet</li> <li>- 4 or 6 fixing holes for housings with feet</li> <li>- lifting rings</li> <li>- earth terminal with an optional jumper screw</li> </ul>
Stator	Insulated low-carbon magnetic steel laminations  Electroplated copper	<ul style="list-style-type: none"> <li>- low carbon content guarantees long-term lamination pack stability</li> <li>- welded laminations</li> <li>- optimised magnetic circuit</li> <li>- insulation or coating system making it possible to withstand the sudden voltage variations caused by the high switching frequencies of IGBT transistor drives in accordance with IEC 34-17</li> <li>- class F insulation</li> <li>- thermal protection provided by PTC probes (1 per phase, 2-wire output)</li> </ul>
Rotor	Insulated low-carbon magnetic steel laminations Aluminium alloy Nd-Fe-B magnet	<ul style="list-style-type: none"> <li>- magnet fixing system. LS patented</li> <li>- dynamically balanced rotor : <ul style="list-style-type: none"> <li>• level A for speeds <math>\leq 3000 \text{ min}^{-1}</math></li> <li>• level B for speeds <math>&gt; 3000 \text{ min}^{-1}</math></li> </ul> </li> </ul>
Shaft	Steel	
End shields	Cast iron	
Bearings and lubrication		<ul style="list-style-type: none"> <li>- ball bearings, C3 play</li> <li>- preloaded NDE bearings</li> <li>- greased for life types up to frame size 225</li> <li>- type regreasable from frame size 250 upwards</li> <li>- insulated bearings depending on the range</li> </ul>
Labyrinth seal Lipseals	Plastic or steel Synthetic rubber	<ul style="list-style-type: none"> <li>- lipseal or deflector at drive end for all flange mounted motors</li> <li>- lipseal, deflector or labyrinth seal for foot mounted motors</li> </ul>
Fan	Composite material or aluminium alloy or steel	- bi-directional
Fan cover	Pressed steel	- fitted, on request, with a drip cover for operation in vertical position, shaft end facing down.
Terminal box	Aluminium alloy	<ul style="list-style-type: none"> <li>- fitted with a terminal block with 3 or 6 steel terminals as standard (brass as an option)</li> <li>- pre-drilled terminal box without cable glands except for PLSRPM with undrilled mounting plate</li> <li>- 1 earth terminal in each terminal box</li> <li>- connector for accessories</li> </ul>

The motor rotor contains a powerful magnetic field. When the rotor is separated from the motor, its field may affect pacemakers or disturb digital devices such as watches, mobile phones, etc.

Assembly or maintenance of the rotor must not be carried out by people with a pacemaker or any other implanted medical electronic device.

**The assembled motor presents no risk.**



# Permanent magnet synchronous motors LSRPM - PLSRPM Construction

## E3 - External finish

Motors conform to the requirements of System Ia

LEROY-SOMER motors are protected with a range of surface finishes. The surfaces receive appropriate special treatments, as shown below.

### Preparation of surfaces

Surface	Treatment
Cast iron	Shot blasting + Primer
Steel	Phosphatization + Primer
	Electrostatic painting or Epoxy powder
Aluminium alloy	Shot blasting

### Definition of atmospheres

An atmosphere is said to be CORROSIVE when components are attacked by oxygen. It is said to be HARSH when components are attacked by bases, acids or salts.

### Paint systems

Products	Atmosphere	System	Applications	Resistance to saline mist in acc. with ISO 12944-2
LSRPM PLSRPM	Non-harsh and not very harsh (indoors, rural or industrial)	Ia	1 polyurethane top coat, 20/30 µm	C3L
	Moderately corrosive: humid, and outdoors (temperate climate)	IIa	1 Epoxy base coat, 30/40 µm 1 polyurethane top coat, 20/30 µm	C3M
	Corrosive: coastal, very humid (tropical climate)	IIIa	1 Epoxy base coat, 30/40 µm 1 Epoxy intermediate coat, 30/40 µm 1 polyurethane top coat, 20/30 µm	C4M
	Substantial chemical attack: frequent contact with bases, acids, alkalis <b>surroundings - neutral environment</b> (not in contact with chlorinated or sulphurous products)	IIIb	1 Epoxy base coat, 30/40 µm 1 Epoxy intermediate coat, 30/40 µm 1 Epoxy top coat, 25/35 µm	C4H

System Ia is for moderate climates and system IIa is for general climates as defined in standard IEC 60721-2-1.

### Paint reference

RAL 3005

# Permanent magnet synchronous motors LSRPM - PLSRPM Construction

## E4 - Mounting arrangements

### Mountings and positions (in accordance with IEC CEI 60034-7)

#### Foot mounted motors

- all frame sizes

**IM 1001** (IM B3)  
- Horizontal shaft  
- Feet on floor

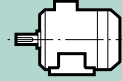

**IM 1071** (IM B8)  
- Horizontal shaft  
- Feet on top

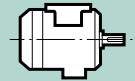

**IM 1051** (IM B6)  
- Horizontal shaft  
- Wall mounted with feet  
on left hand side when  
viewed from drive end

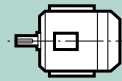

**IM 1011** (IM V5)  
- Vertical shaft facing down  
- Feet on wall

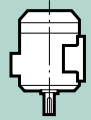

**IM 1061** (IM B7)  
- Horizontal shaft  
- Wall mounted with feet  
on right hand side when  
viewed from drive end

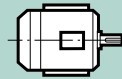

**IM 1031** (IM V6)  
- Vertical shaft facing up  
- Feet on wall

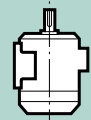

#### (FF) flange mounted motors

- all frame sizes  
(IM 3001 for frame size  $\leq 225$ )

**IM 3001** (IM B5)  
- Horizontal shaft

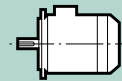

**IM 2001** (IM B35)  
- Horizontal shaft  
- Feet on floor

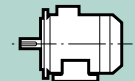

**IM 3011** (IM V1)  
- Vertical shaft facing down

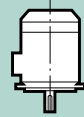

**IM 2011** (IM V15)  
- Vertical shaft facing down  
- Feet on wall

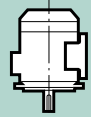

**IM 3031** (IM V3)  
- Vertical shaft facing up

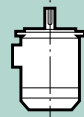

**IM 2031** (IM V36)  
- Vertical shaft facing up  
- Feet on wall

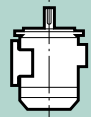

#### (FT) face mounted motors

- all frame sizes  $\leq 132$  mm

**IM 3601** (IM B14)  
- Horizontal shaft

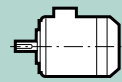

**IM 2101** (IM B34)  
- Horizontal shaft  
- Feet on floor

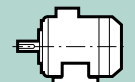

**IM 3611** (IM V18)  
- Vertical shaft facing down

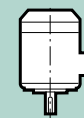

**IM 2111** (IM V58)  
- Vertical shaft facing down  
- Feet on wall

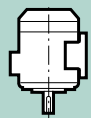

**IM 3631** (IM V19)  
- Vertical shaft facing up

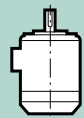

**IM 2131** (IM V69)  
- Vertical shaft facing up  
- Feet on wall

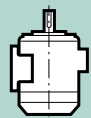

#### Motors without drive end shield

**Caution:** the protection (IP) specified on the IM B9 and IM B15 motor plates is ensured by the customer when the motor is assembled

**IM 9101** (IM B9)  
- Threaded tie rods  
for fixing  
- Horizontal shaft

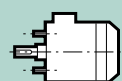

**IM 1201** (IM B15)  
- Foot mounted  
and threaded tie rods  
- Horizontal shaft

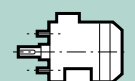

# Permanent magnet synchronous motors LSRPM - PLSRPM Construction

## E5 - Bearings and Lubrication

### E5.1 - LUBRICATION TYPE

LSRPM series bearings are lubricated with a polyurea soap-based grease.

### E5.2 - PERMANENTLY GREASED BEARINGS

Under normal operating conditions, the service life (L10h) of the lubricant is 25,000 hours for a machine installed horizontally and for ambient temperatures less than 25°C.

### E5.3 - GREASING INTERVAL

The chart opposite shows the greasing intervals, depending on the type of motor, for open bearing assemblies of frame size  $\geq 200$  fitted with grease nipples, operating at an ambient temperature of 25°C on a horizontal shaft machine.

The chart opposite is valid for LSRPM motors lubricated with EXXON MOBILE POLYREX EM 103 grease, which is used as standard.

### E5.4 - SPECIAL CONSTRUCTION AND ENVIRONMENT

For a machine operating at an ambient temperature of 25°C and installed with shaft vertical, the greasing intervals are 80% of the values given in the chart.

Motors operating at an ambient temperature of 40°C need more frequent lubrication. The intervals between greasing will be about half of those given in the chart.

**Note:** the quality and quantity of grease and the regreasing interval are shown on the machine nameplate.

### E5.5 - PERMISSIBLE LOADS

**Permissible loads:** Motors in the 750 to 3600 series are designed to operate with direct or indirect coupling: permissible loads on request.

Motors in the 4500 and 5500 series are designed to operate with direct coupling. For other cases, please consult Leroy-Somer.

### E5.6 - PRECAUTIONS

For the 4500 and 5500 series, a running-in period is necessary. Please refer to the installation and maintenance manual.

The bearings and type of grease nipple are defined in accordance with the table below :

Range	Frame size (mm)	Lubrication type N.D.E. / D.E.	Ball bearing type	
			N.D.E.	D.E.
5500	$\leq 160$	Greased for life in the factory	standard	standard
	200	Bearings with grease nipples	insulated	insulated
4500	$\leq 160$	Greased for life in the factory	standard	standard
	200	Bearings with grease nipples	insulated	standard
	$> 200$	Bearings with grease nipples	insulated	insulated
3600	$\leq 200$	Greased for life in the factory	standard	standard
	$> 200$	Bearings with grease nipples	insulated for frame size $> 250$	standard
3000	$\leq 200$	Greased for life in the factory	standard	standard
	$> 200$	Bearings with grease nipples	insulated for frame size $> 250$	standard
2400	$\leq 200$	Greased for life in the factory	standard	standard
	$> 200$	Bearings with grease nipples	insulated for frame size $> 280SD$	standard
1800	$\leq 200$	Greased for life in the factory	standard	standard
	$> 200$	Bearings with grease nipples	insulated for frame size $> 280$	standard
1500	$\leq 200$	Greased for life in the factory	standard	standard
	$> 200$	Bearings with grease nipples	insulated for frame size $> 280$	standard
900	$\leq 200$	Greased for life in the factory	standard	standard
	$> 200$	Bearings with grease nipples	standard	standard
750	$\leq 200$	Greased for life in the factory	standard	standard
	$> 200$	Bearings with grease nipples	standard	standard
375	$\leq 160$	Greased for life in the factory	standard	standard

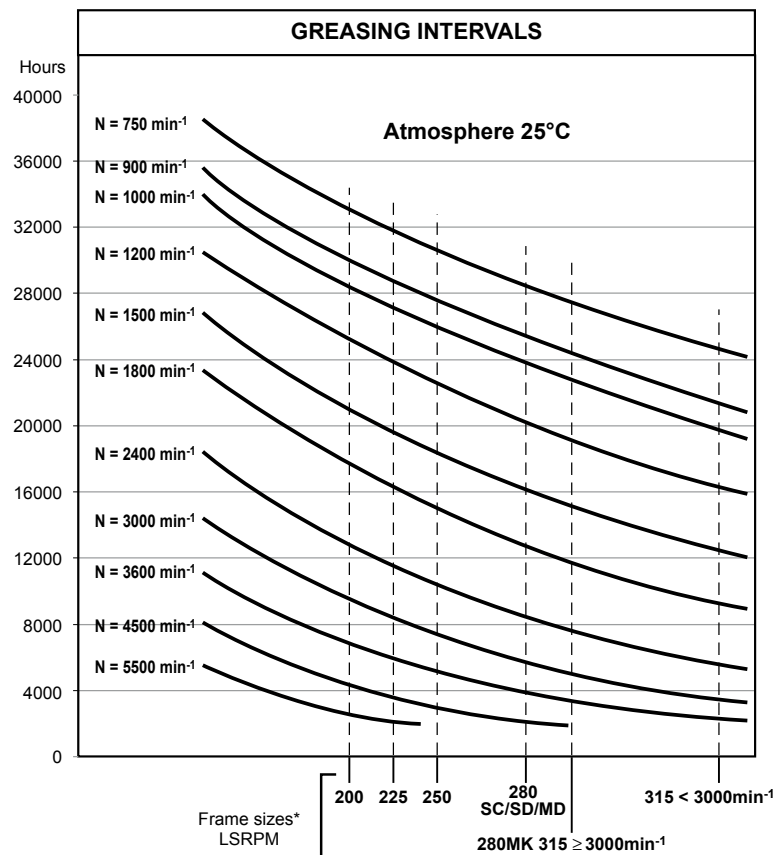

\*Consult for PLSRPM

# Permanent magnet synchronous motors LSRPM - PLSRPM Construction

## E6 - Connection

### E6.1 - TERMINAL BOX

Placed as standard on the top of the motor near the drive end, the terminal box has IP 55 protection.

The standard position of the cable glands is on the right, seen from the drive end, position A1.

### E6.2 - TIGHTENING TORQUE FOR THE NUTS ON THE TERMINAL BLOCKS

Terminal	M4	M5	M6	M8	M10	M12	M16
Torque N. m	2	3.2	5	10	20	35	65

▼ Terminal box positions in relation to the drive end

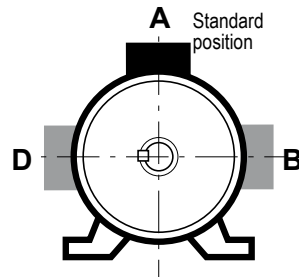

▼ Cable gland positions in relation to the drive end

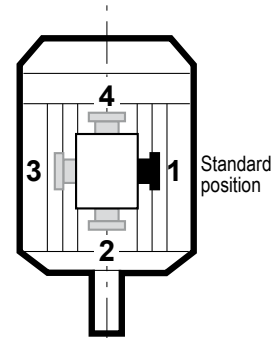

Only positions 1 and 3 are possible

### E6.3 - TERMINAL BOX DRILLING FOR CABLE GLANDS

Motor type	Power + auxiliaries	
	Number of drill holes	Drill hole diameter
LSRPM 90 S/SL	2	ISO M25x1.5 + 1xM16
LSRPM 100 L		
LSRPM 132 M		
LSRPM 160 LR/MP		
LSRPM 200 L/LU		
LSRPM 200 L1		
LSRPM 200 L2/LU2	3	2xM40 + 1xM16
LSRPM 225 ST1/MR1		
LSRPM 225 SG/ST2/SR2		
LSRPM 250 SE/ME		
LSRPM 250 SE1/ME1		Removable undrilled mounting plate
LSRPM 280 SD/MD	0	2xM63 + 1xM16
LSRPM 280 SC1/SD1/MK1		
LSRPM 315 SP1/SR1/MR1		
PLSRPM 315 LD		Removable undrilled mounting plate

### E6.4 - ENCODER CONNECTION

For the encoder option, connection is made via a connector fixed on the terminal box.

# Permanent magnet synchronous motors LSRPM - PLSRPM Construction

## E7 - Machine vibration level

### E7.1 - VIBRATION LEVEL - BALANCING

Inaccuracies due to construction (magnetic, mechanical and air-flow) lead to sinusoidal (or pseudo sinusoidal) vibrations over a wide range of frequencies. Other sources of vibration can also affect motor operation: such as poor mounting, incorrect drive coupling, end shield misalignment, etc.

We shall first of all look at the vibrations emitted at the operating frequency, corresponding to an unbalanced load, whose amplitude swamps all other frequencies and on which the dynamic balancing of the mass in rotation has a decisive effect.

Under standard ISO 8821, rotating machines can be balanced with or without a key or with a half-key on the shaft extension.

Standard ISO 8821 requires the balancing method to be marked on the shaft extension as follows:

- half-key balancing: letter H
- full key balancing: letter F
- no-key balancing: letter N.

### Measured parameters

The vibration speed can be chosen as the variable to be measured. This is the speed at which the machine moves either side of its static position. It is measured in mm/s.

As the vibratory movements are complex and non-harmonic, it is the root mean square (rms) value of the speed of vibration which is used to express the vibration level.

Other variables that could also be measured are the vibratory displacement amplitude (in  $\mu\text{m}$ ) or vibratory acceleration (in  $\text{m/s}^2$ ).

If the vibratory displacement is measured against frequency, the measured value decreases with the frequency: high frequency vibrations cannot be measured.

If the vibratory acceleration is measured, the measured value increases with the frequency: low-frequency vibrations (unbalanced loads) cannot be measured here.

Machines are balanced :  
- level A for speeds  $\leq 3000 \text{ min}^{-1}$   
- level B for speeds  $> 3000 \text{ min}^{-1}$

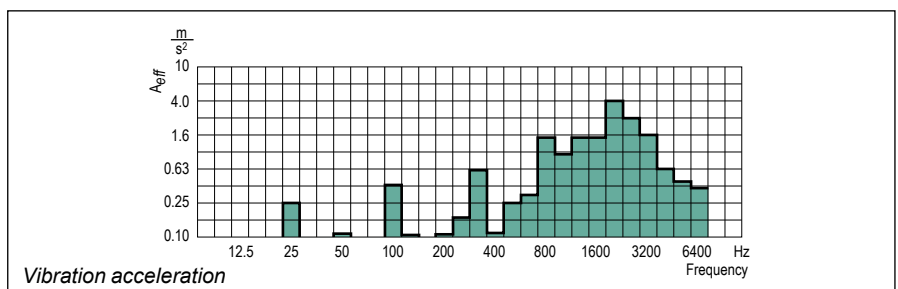
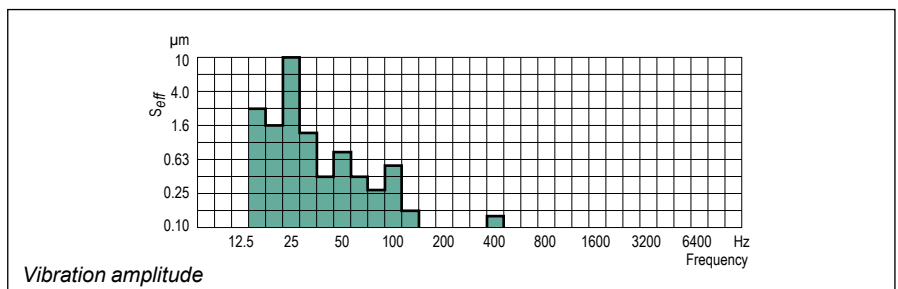
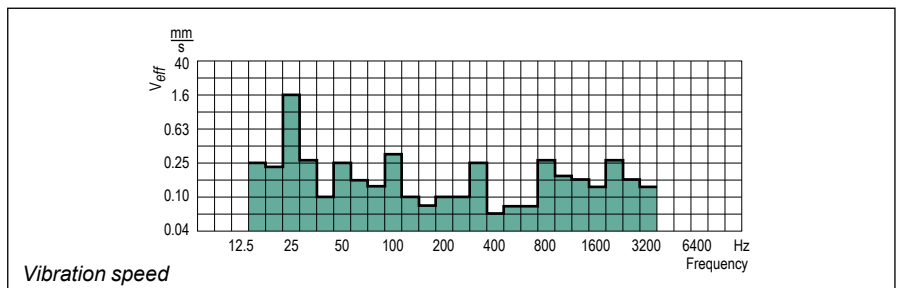
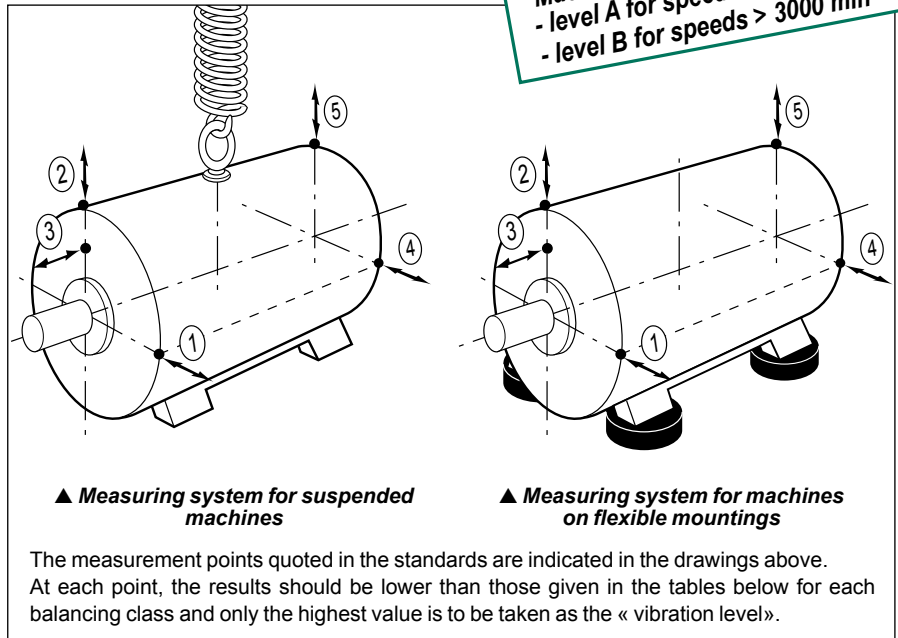

# Permanent magnet synchronous motors LSRPM - PLSRPM Construction

## E7 - Machine vibration level

**E7.2 - MAXIMUM VIBRATION MAGNITUDE LIMITS (RMS VALUES) IN TERMS OF DISPLACEMENT, SPEED AND ACCELERATION FOR A FRAME SIZE H (IEC 60034-14)**

Vibration level	Frame size H (mm)								
	56 < H ≤ 132			132 < H ≤ 280			H > 280		
	Displacement μm	Speed mm/s	Acceleration m/s <sup>2</sup>	Displacement μm	Speed mm/s	Acceleration m/s <sup>2</sup>	Displacement μm	Speed mm/s	Acceleration m/s <sup>2</sup>
A	25	1.6	2.5	35	2.2	3.5	45	2.8	4.4
B	11	0.7	1.1	18	1.1	1.7	29	1.8	2.8



# Permanent magnet synchronous motors

## LSRPM - PLSRPM

### General information

PAGE

F1 - Quality commitment

58

F2 - Standards and approvals

59 to 61

F3 - Designation

62

# Permanent magnet synchronous motors LSRPM - PLSRPM General information

## F1 - Quality commitment

LEROY-SOMER's quality management system is based on:

- Control of procedures right from the initial sales offering until delivery to the customer, including design, manufacturing start-up and production.

- A total quality policy based on making continuous progress in improving operational procedures, involving all departments in the company in order to give customer satisfaction as regards delivery times, conformity and cost.

- Indicators used to monitor procedure performance.

- Corrective actions and advancements with tools such as FMECA, QFD, MAVP, MSP/MSQ and Hoshin type improvement workshops on flows, process re-engineering, plus Lean Manufacturing and Lean Office.

- Annual surveys, opinion polls and regular visits to customers in order to ascertain and detect their expectations.

Personnel are trained and take part in the analyses and the actions for continuously improving the procedures.

LEROY-SOMER has entrusted the certification of its expertise to various international organisations.

Certification is granted by independent professional auditors, and recognises the high standards of the **company's quality assurance procedures**. All activities resulting in the final version of the machine have therefore received official **ISO 9001: 2000 certification from the DNV**. Similarly, our environmental approach has enabled us to obtain ISO 14001: 2004 certification.

Products for particular applications or those designed to operate in specific environments are also approved or certified by the following organisations: LCIE, DNV, INERIS, EFECTIS, UL, BSRIA, TUV, CCC, GOST, which check their technical performance against the various standards or recommendations.



### ISO 9001 : 2000



# Permanent magnet synchronous motors



## LSRPM - PLSRPM

### General information

## F2 - Standards and approvals

### ORGANIZATION OF STANDARDS AUTHORITIES

#### International bodies

<p><b>Worldwide</b></p> 	<p>General standardization</p> <p><b>ISO</b></p> <p>International Standards Organisation</p> <div style="display: flex; justify-content: space-around;"> <div style="border: 1px solid black; padding: 2px; text-align: center;">TC Technical committees</div> <div style="border: 1px solid black; padding: 2px; text-align: center;">SC Sub-committee</div> <div style="border: 1px solid black; padding: 2px; text-align: center;">WG Working groups</div> </div>	<p>Electronics/electrotechnical standardization</p> <p><b>IEC</b></p> <p>International Electrotechnical Commission</p> <div style="display: flex; justify-content: space-around;"> <div style="border: 1px solid black; padding: 2px; text-align: center;">TC Technical committees</div> <div style="border: 1px solid black; padding: 2px; text-align: center;">SC Sub-committee</div> <div style="border: 1px solid black; padding: 2px; text-align: center;">WG Working groups</div> </div>
<p><b>European</b></p> 	<p><b>CEN</b></p> <p>European Committee for Standards</p> <p><b>ECISS</b></p> <p>European Committee for Iron and Steel Standardization</p> <div style="border: 1px solid black; padding: 2px; text-align: center; margin: 10px auto; width: 80px;">TC Technical committees</div>	<p><b>CENELEC</b></p> <p>European Committee for Electrotechnical Standardization</p> <div style="display: flex; justify-content: space-around; margin: 10px auto;"> <div style="border: 1px solid black; padding: 2px; text-align: center; width: 60px;">TC Technical committees</div> <div style="border: 1px solid black; padding: 2px; text-align: center; width: 60px;">SC Sub-committee</div> <div style="border: 1px solid black; padding: 2px; text-align: center; width: 60px;">AHG Ad hoc groups</div> </div>

Country	Initials	Name
AUSTRALIA	SAA	Standards Association of Australia
BELGIUM	IBN	Institut Belge de Normalisation
CIS (ex-USSR)	GOST	Gosudarstvenne Komitet Standartov
DENMARK	DS	Dansk Standardiseringsraad
FINLAND	SFS	Suomen Standardisoimisliitto
FRANCE	AFNOR including UTE	Association Française de Normalisation including: Union Technique de l'Électricité
GERMANY	DIN/VDE	Verband Deutscher Elektrotechniker
GREAT BRITAIN	BSI	British Standards Institution
ITALY	IEC	Comitato Electrotechnico Italiano
JAPAN	JIS	Japanese Industrial Standard
NETHERLANDS	NNI	Nederlands Normalisatie - Instituut
NORWAY	NFS	Norges Standardiseringsforbund
SAUDI ARABIA	SASO	Saudi Arabian Standards Organization
SPAIN	UNE	Una Norma Española
SWEDEN	SIS	Standardiseringskommissionen I Sverige
SWITZERLAND	SEV or ASE	Schweizerischer Elektrotechnischer Verein
UNITED STATES	ANSI including NEMA	American National Standards Institute including: National Electrical Manufacturers

# Permanent magnet synchronous motors

## LSRPM - PLSRPM

### General information

## F2 - Standards and approvals

### List of standards quoted in this document

Reference		International standards
IEC 60034-1	EN 60034-1	Electrical rotating machines: ratings and operating characteristics
IEC 60034-2		Electrical rotating machines: methods for determining losses and efficiency from tests (additional losses added as a fixed percentage)
IEC 60034-2-1		Electrical rotating machines: methods for determining losses and efficiency from tests (measured additional losses)
IEC 60034-5	EN 60034-5	Electrical rotating machines: classification of degrees of protection provided by casings of rotating machines.
IEC 60034-6	EN 60034-6	Electrical rotating machines (except traction): cooling methods
IEC 60034-7	EN 60034-7	Electrical rotating machines (except traction): symbols for mounting positions and assembly layouts
IEC 60034-8		Electrical rotating machines: terminal markings and direction of rotation
IEC 60034-9	EN 60034-9	Electrical rotating machines: noise limits
IEC 60034-12	EN 60034-12	Starting characteristics for single-speed 3-phase cage induction motors for supply voltages less than or equal to 660V.
IEC 60034-14	EN 60034-14	Electrical rotating machines: mechanical vibrations of certain machines with a frame size above or equal to 56 mm. Measurement, evaluation and limits of vibrational intensity.
IEC 60034-30		Electrical rotating machines: efficiency classes for single-speed three-phase cage induction motors (Code IE)
IEC 60038		IEC standard voltages
IEC 60072-1		Dimensions and power series for electrical rotating machines: designation of casings between 56 and 400 and flanges between 55 and 1080.
IEC 60085		Evaluation and thermal classification of electrical insulation.
IEC 60721-2-1		Classification of natural environment conditions. Temperature and humidity.
IEC 60892		Effects of an imbalance in the voltage system on the characteristics of three-phase squirrel-cage induction motors.
IEC 61000-2-10/11 et 2-2		Electromagnetic compatibility (EMC): environment
IEC guide 106		Guidelines on the specification of environmental conditions for the determination of operating characteristics of equipment.
ISO 281		Bearings - Basic dynamic loadings and nominal bearing life
ISO 1680	EN 21680	Acoustics - Test code for measuring airborne noise emitted by electrical rotating machines: a method for establishing an expert opinion for free field conditions over a reflective surface
ISO 8821		Mechanical vibration - Balancing. Conventions on shaft keys and related parts
	EN 50102	Degree of protection provided by the electrical housing against extreme mechanical impacts.
ISO 12944-2		Corrosivity category

# Permanent magnet synchronous motors

## LSRPM - PLSRPM

### General information

## F2 - Standards and approvals

### Approvals

Certain countries recommend or insist on approval from national organizations.  
Approved products must carry the recognized mark on their identification plates.

Country	Initials	Organization
USA	UL	Underwriters Laboratories
CANADA	CSA	Canadian Standards Association

### International and national standard equivalents

International reference standards		National standards				
IEC	Title (summary)	FRANCE	GERMANY	U.K.	ITALY	SWITZERLAND
60034-1	Ratings and operating characteristics	NFEN 60034-1 NFC 51-120 NFC 51-200	DIN/VDE 0530	BS 4999	CEI 2.3.VI.	SEV ASE 3009
60034-5	Classification of degrees of protection	NFEN 60034-5	DIN/EN 60034-5	BS EN 60034-5	UNEL B 1781	
60034-6	Cooling methods	NFEN 60034-6	DIN/EN 60034-6	BS EN 60034-6		
60034-7	Mounting arrangements and assembly layouts	NFEN 60034-7	DIN/EN 60034-7	BS EN 60034-7		
60034-8	Terminal markings and direction of rotation	NFC 51 118	DIN/VDE 0530 Teil 8	BS 4999-108		
60034-9	Noise limits	NFEN 60034-9	DIN/EN 60034-9	BS EN 60034-9		
60034-12	Starting characteristics for single-speed motors powered from the mains $\leq 660$ V	NFEN 60034-12	DIN/EN 60034-12	BS EN 60034-12		SEV ASE 3009-12
60034-14	Mechanical vibration in machines of frame size $> 56$ mm	NFEN 60034-14	DIN/EN 60034-14	BS EN 60034-14		
60072-1	Dimensions and output powers for machines of between 56 and 400 frame and flanges of between 55 and 1080	NFC 51 104 NFC 51 105	DIN 748 (~) DIN 42672 DIN 42673 DIN 42631 DIN 42676 DIN 42677	BS 4999		
60085	Evaluation and thermal classification of electrical insulation	NFC 26206	DIN/EN 60085	BS 2757		SEV ASE 3584

Note: DIN 748 tolerances do not conform to IEC 60072-1.

# Permanent magnet synchronous motors

## LSRPM - PLSRPM

### General information

## F3 - Designation

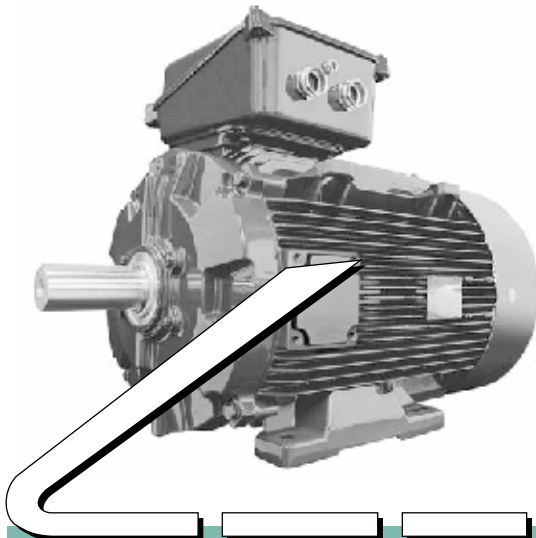

**IP 55**  
**Cl. F**

The complete motor **reference** described below will enable you to **order** the desired equipment.

The selection method consists of following the terms in the designation.

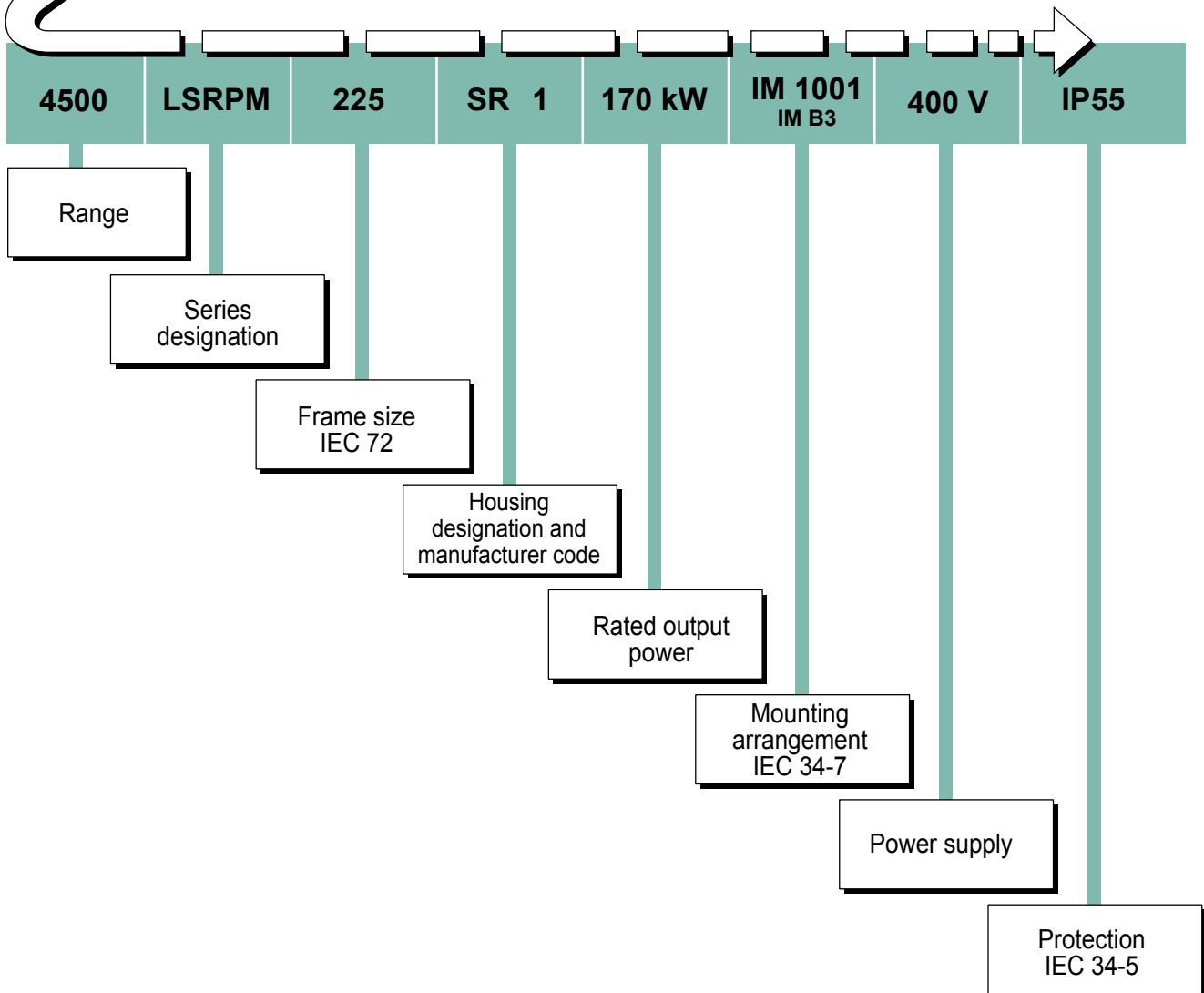

# Notes

# Notes

# Notes

**I - SCOPE OF APPLICATION**

These General Conditions of Sale («GCS») shall apply to the sale of all products, components, software and services (referred to as «Products») proposed or sold by the Seller to the Client. Said GCS shall also apply to all quotation or offers made by the Seller, and are an integral part of all orders. «Seller» is understood to mean all companies directly or indirectly controlled by LEROY-SOMER. As a complementary measure, orders are also subject to the latest version in force of the Inter-Union General Conditions of Sale for France of the F.I.E.E.C. (*Fédération des Industries Electroniques, Electroniques et de Communication* [Federation of Electrical, Electronic and Communication Industries]), inasmuch as they are not contrary to the GCS.

The acceptance of the Seller's offers or quotations, or any order, entails the acceptance without reservation of these GCS and rules out all contrary provisions shown on all other documents and, in particular, on the Client's order forms and the Client's General Conditions of Purchase.

If the sale concerns castings, by way of derogation to Paragraph 1 above, said castings shall be subject to the latest version in force of the *Conditions Générales Contractuelles des Fonderies Européennes* [General Contractual Conditions of European Foundries].

**The Products and services sold pursuant to these GCS may under no circumstances be used for applications in the nuclear field, as such sales expressly fall under technical specifications and specific contracts that the Seller reserves the right to refuse.**

**II - ORDERS**

All orders, even those taken by the Seller's agents and representatives, and regardless of the transmission method, shall only bind the Seller after written acceptance thereby of the order.

The Seller reserves the option of modifying the characteristics of its Products without notice. However, the Client shall retain the possibility of specifying the characteristics on which its commitment is contingent. In the absence of any such express stipulation, the Client may not refuse delivery of new, modified Products.

The Seller may not be held liable for an unsatisfactory selection of Products if said selection results from conditions of use that are incomplete and/or mistaken, or not disclosed to the Seller by the Client. Except in the event of a stipulation to the contrary, the offers and quotations remitted by the Seller shall only be valid for thirty days as from the date on which they are drawn up.

Where the Products must comply with standards, specific regulations and/or be received by control and inspection agencies, the price request must be accompanied by the technical specification, all terms and conditions the Seller must comply with. Reference shall be made thereto on the quotation or offer. Approval and attendance costs shall always be borne by the Client.

**III - PRICES**

Tariffs are expressed exclusive of tax and may be revised without notice.

Prices are either deemed to be firm for the period of validity specified on the quotation, or subject to a revision formula attached to the offer and which specifies, according to the regulations, parameters pertaining to the materials, products, various services and salaries for which the indices are published in the B.O.C.C.R.F. (*Bulletin Officiel de la Concurrence, de la Consommation et de la Répression des Fraudes* [French Official Journal of Competition and Consumer Matters, and Anti-Fraud Measures]). All additional costs, in particular approval costs, specific checks, etc., shall be invoiced in addition.

**IV - DELIVERY**

Sales are governed by the latest edition in force of the INCOTERMS published by the Internal Chamber of Commerce («I.C.C. INCOTERMS»).

The Products shall be dispatched according to the conditions stated on the order acknowledgement issued by the Seller for all orders of Products.

Except in the event of specific provisions, the prices correspond to Products that are made available in the Seller's factories, including basic packaging.

Except in the event of a provision to the contrary, the Products shall always be transported at the risk of the addressee. In all cases, it shall be the responsibility of the addressee to make any claims to the carrier, within the delivery time and in the forms specified by law, concerning the state or number of parcels received, and to concomitantly provide the Seller with a copy of such declaration. Failure to comply with said procedure shall exempt the Seller from any liability. In any event, the Seller's liability may not exceed the amount of the indemnities received from its insurers.

If the provisions concerning transportation are amended by the Client subsequent to the acceptance of the order, the Seller reserves the right to invoice any supplemental costs that may result therefrom.

Except in the event of a contractual or statutory obligation to the contrary, packaging shall not be returnable.

In the event that a delivery of Products is delayed for a reason not attributable to the Seller, the Products stored on the Seller's premises shall be insured at the exclusive risk of the Client. Consideration for storage, costs will be invoiced at a rate of 1% (*one per cent*) of the total amount of the order, per week or partial week of storage, with no deductible or *de minimis* amount, as from the date of Products availability provided for in the contract. Upon expiration of a period of thirty days as from said date, the Seller may, at its discretion, either freely dispose of the Products and/or agree with the Client on a new delivery date for said Products, or invoice the Client in full for payment, according to the timeframes and amount provided for contractually. In any event, down payments shall inure to the Seller as indemnities, without prejudice to any other action the Seller may take.

**V - DELIVERY TIME**

The Seller shall only be bound by the delivery time mentioned on its order acknowledgement. Said delivery time shall only start to run as from the date of issuance of the order acknowledgement by the Seller, and subject to the fulfilment of the conditions provided for on the confirmation receipt, in particular receipt of the down payment for the order, notification of the opening of an operative irrevocable and confirmed documentary credit that complies in all respects to the Seller's request (*in particular regarding the amount, currency, validity and licence*), acceptance of the payment conditions accompanied by the implementation of any guarantees requested, etc.

Exceeding delivery time shall not grant the Client entitlement to damages and/or penalties.

Except in the event of a specific condition to the contrary, the Seller reserves the right to make partial deliveries.

Delivery times shall be interrupted by right and without the need for any judicial formalities, by any failure to pay or late payment by the Client.

**VI - TESTS - QUALIFICATION**

The Products manufactured by the Seller are checked and tested before leaving its factories. Clients may be present at said tests if specified on the order.

Specific tests and/or trials, as well as approval of Products, requested by the Client, whether carried out on the Client's premises or in the Seller's factories, on site, or by control and inspection agencies, must be specified on the order and are always at Client's expense.

Prototypes for Products specially developed or adapted for a Client must be qualified by the Client before serial production in order to ensure that it is compatible with the other components that make up its equipment, and that it is adapted to the intended use. Said qualification will also enable the Client to ensure that the Products comply with the technical specification. In this respect, the Client and Seller shall sign a Product Approval Form in two original, one of which shall be retained by the Client and one by the Seller.

In the event that the Client requires delivery without having firstly qualified the Products, said Products shall be delivered as they stand and shall always be deemed to be prototypes: the Client shall then be solely liable for using the Products or delivering them to its own clients. However, the Seller may also decide not to deliver the Products that have not received the Client's prior approval.

**VII - PAYMENT CONDITIONS**

All sales shall be deemed to be completed and payable at the Seller's registered office, without any possible derogation, regardless of the payment method, where the contract was concluded and where delivery was made.

Where the Client is located out of French territory, invoices shall be payable in cash upon receipt, or by a bank draft or a bill of exchange, within 30 (thirty) days net.

All early payment compared to the deadline fixed shall give right to a discount of 0.2% (*nought point two per cent*) per month, of the amount concerned of the invoice.

Except in the event of provisions to the contrary, where the Client is located outside of French Territory, invoices shall be payable in cash against remittance of shipping documents, or by irrevocable documentary credit confirmed by a first rate French bank, at Client's expense.

Payment shall be understood to mean the funds being made available on the Seller's bank account and must imperatively be made in the invoicing currency.

Pursuant to French Law no. 2008-776 of 4 August 2008, failure to pay an invoice when due shall trigger, after service of formal notice that has remained without effect, payment to the Seller of a flat-rate penalty on the due date of the receivable, which shall be applied to amount inclusive of tax of monies owed if the invoice is liable to VAT (*Value Added Tax*), and the suspension of pending orders. Said penalty is equal to the European Central Bank interest rate on the main refinancing operations + 10 basis points.

The collection of said monies via litigation shall trigger an increase of 15% (*fifteen per cent*) of the amount claimed, with a minimum of Euros 500 exclusive of tax (*five hundred euros exclusive of tax*), with tax in addition if due.

Moreover, subject to compliance with the statutory provisions in force, in the event of total or partial failure to pay any invoice or instalment whatsoever, regardless of the payment method used, all amounts that remain owed to the Seller (*including its subsidiaries, affiliated or allied companies, whether French or foreign*) for all deliveries and services, regardless of the due date originally provided for, shall immediately become due.

Notwithstanding any specific payment conditions provided for between the parties, the Seller reserves the right to require, in the event of a decline in the Client's credit rating, a payment incident or bankruptcy of the Client:

- the payment in cash, before the Products leave the factory, for all orders currently being fulfilled,
- down payments to be made on all orders,
- alternative or different payment guarantees.

**VIII - PAYABLE AND RECEIVABLE BALANCE**

Except where prohibited by law, the Seller and the Client expressly agree to balance their payables and receivables arising from their trade relations, even if all conditions defined by law for legal balancing are not met.

For the application of said clause, the Seller shall mean any company of the LEROY-SOMER Group.

**IX - TRANSFER OF RISK / RESERVE OF TITLE**

**Risk shall be transferred as soon as the Products are made available, according to the delivery conditions stipulated on the order acknowledgement.**

**The transfer to the Client of title shall take place after payment in full. In the event that the restitution of the Products delivered is claimed by the Seller, the Seller is entitled to retain any down payment as compensation.**

**Remittance of a bill that creates an obligation to pay (bill of exchange or other) shall not constitute payment and discharge.**

**For as long as the price has not been paid in full, the Client is required to inform the Seller, within twenty-four hours, of the sequestration, requisition or confiscation of the Products for the benefit of a third party, and to take all protective measures to make known the Seller's property right in the event of action by creditors, and to cause such right to be respected.**

**X - CONFIDENTIALITY**

Each of the parties undertakes to maintain the confidentiality of all technical, trade, financial or other information received from the other party, whether orally, in writing or by any other means of communication, when any order is negotiated and/or fulfilled.

This confidentiality obligation shall apply throughout the period during which the order is fulfilled and for 5 (five) years subsequent to completion or cancellation thereof, regardless of the reasons therefor.

**XI - INDUSTRIAL AND INTELLECTUAL PROPERTY**

Data, studies, results, information or software, whether patentable or not obtained by the Seller when any order is fulfilled shall remain the exclusive property of the Seller.

With the exception of instruction and maintenance manuals, documents of any nature remitted to the Client shall remain the exclusive property of the Seller and must be returned to it upon request, even if the Client was invoiced for part of the cost of the study, and said documents may not be disclosed to third parties or used without the Seller's prior written agreement.

**XII - CANCELLATION / TERMINATION**

The Seller reserves the right to cancel or terminate immediately, at the Seller's discretion, by right and without the need for any judicial formalities, the contract in the event of failure to pay any portion whatsoever of the price, when due, or in the event of any breach of any of the Client's contractual obligations. Down payments and any amount already paid shall remain in Seller's hands in the form of indemnities, without prejudice to the Seller's right to claim damages. In the event that the contract is cancelled, the Products must be returned to the Seller immediately, regardless of where the Products are located, at Client's expense and risk, under penalty of 10% (*ten per cent*) of the value thereof, per week's delay.

**XIII - WARRANTY**

The Seller warrants the Products against all operating defects caused by a material or manufacturing fault, for a period of twelve months as from the date on which the Products are made available, unless a different statutory provision subsequently applies, under the conditions defined below.

The warranty may only be triggered insofar as the Products have been stored, used and maintained in accordance with the Seller's instructions and manuals. The warranty does not apply where the defect results, in particular, from:

- inadequate monitoring, maintenance or storage,
- normal wear and tear on the Products,
- servicing or modification of the Products without the Seller's prior written authorisation,
- abnormal use of the Products or use of the Products for a purpose other than that intended,
- faulty installation of the Products on the premises of the Client and/or the end user,
- failure by the Client to disclose the purpose or conditions of use of the Products,
- failure to use genuine spare parts,
- force majeure or any event that is beyond the control of the Seller.

In any case, the warranty is limited to the replacement or repair of the parts or Products deemed faulty by the Seller's technical departments. If the repair is entrusted to a third party, the repair shall only be carried out once the Seller has agreed to the quotation for the repair.

All Products returns must have been given the Seller's prior, written authorisation.

The Products to be repaired must be dispatched carriage paid, to the address given by the Seller. If the Products are not accepted under warranty, their return to the Client shall be invoiced to the Client or the end user.

This warranty shall apply to the Seller's Products that are made readily available and therefore does not cover the de-installation and re-installation of said Products in the equipment into which it is mounted.

Repair, modification or replacement of any part or Product during the warranty period may not result in the warranty period being extended.

The provisions of this article constitute the Seller's sole obligation concerning the warranty of the Products delivered.

**XIV - LIABILITY**

The Seller's liability is strictly limited to the obligations stipulated in these GCS and those expressly accepted by the Seller. All penalties and indemnities provided for therein constitute lump sum damages that include discharge for the Seller and are exclusive of any other penalty or indemnification.

With the exception of the Seller's gross negligence and the compensation of bodily injury, the Seller's liability shall be limited, in total, to the contractual amount, exclusive of tax, of the Product(s) that give(s) right to compensation.

The Seller may under no circumstances be required to indemnify consequential, indirect and / or punitive damages that the Client may use as the basis for a claim; as a result, the Seller may not be required to indemnify, in particular, production losses, operating losses or lost profit or, in general, any damage eligible for indemnification other than bodily injury or damage to property.

The Client undertakes to hold harmless the Seller and / or its insurers from any and all claims made by its insurers and/or any third party in a contractual relation with the Client, in excess of the limit and for the exclusions listed above.

**XV - SPARE PARTS AND ACCESSORIES**

Spare parts and accessories shall be supplied upon request, to the extent of their availability. Associated costs shall be invoiced in addition. The Seller reserves the right to require a minimum quantity or invoicing amount per order.

**XVI - WASTE MANAGEMENT**

The Products that form the purpose of the sale do not fall within the scope of the European Directive 2002/96/EC (WEEE) dated January 27<sup>th</sup>, 2003, and all related legislation of Member States of the European Union that result therefrom, on the composition of electrical and electronic equipment and the disposal of waste from such equipment.

In accordance with Article L 541-2 of the French Environment Code, it is the responsibility of the waste holder to ensure the disposal thereof or to cause the disposal thereof at its own expense.

**XVII - FORCE MAJEURE**

With the exception of the Client's obligation to pay the monies owed to the Seller in respect of an order, the Client and Seller may not be held liable for the total or partial failure to perform their contractual obligations if such failure results from the occurrence of a force majeure. Delays or disturbances in production that totally or partially result from war (whether declared or not), terrorist act, strikes, riots, accidents, fires, floods, natural disasters, transportation delays, shortage of components or materials, governmental decision or action (including prohibition on import/export or the withdrawal of an import/export licence) shall, in particular, be deemed a force majeure.

If one of the parties is delayed or prevented from performing its obligations by reason of this Article for a period in excess of 180 consecutive days, each party may then terminate, by right and without any need for judicial formalities, the unperformed part of the order, by written notice to the other party, without liability. However, the Client shall be required to pay the price agreed pertaining to the Products already delivered on the date of termination.

**XVIII - PROHIBITION ON UNLAWFUL PAYMENTS**

The Client shall refrain from being engaged in any activity that would expose the Seller or any of its affiliates to a risk of penalties under laws and regulations of any relevant jurisdiction prohibiting improper payments, including but not limited to bribes or gifts of an obviously unreasonable amount, to any government or agency officials, to political parties or their officials or candidates for public office, or to any employee of any customer or supplier.

**XIX - TRADE COMPLIANCE LAWS**

The Client agrees that all applicable import, export control and sanctions laws, regulations, orders and requirements, as they may be amended from time to time, including without limitation those of the European Union, the United States of America, and the jurisdictions in which the Seller and the Client are established or from which Products may be supplied, and the requirements of any licences, authorisations, general licences or licence exceptions relating thereto ("Trade Compliance Laws") will apply to its receipt and use of Products, as well as related services and technology. In no event shall the Client use, transfer, release, export or re-export the Products, related services or technology in violation of Trade Compliance Laws.

Seller shall have no obligation to supply any Products, or services unless and until it has received any necessary licences or authorisations or has qualified for general licences or licence exceptions under Trade Compliance Laws.

If for any reason any such licences, authorisations or approvals are denied or revoked, or if there is a change in any Trade Compliance Laws that would prohibit Seller from fulfilling the contract, or would in the reasonable judgement of Seller otherwise expose Seller and/or Seller's Affiliate(s) to a risk of liability under Trade Compliance Laws, Seller shall be relieved without liability of all obligations under the contract.

**XX - SEVERABILITY**

All clauses and/or provisions of these General Conditions that are deemed or become null or void shall not cause the nullity or voidance of the contract, but solely the clause and/or provision concerned.

**XXI - DISPUTES**

**THIS CONTRACT SHALL BE GOVERNED BY AND INTERPRETED IN ACCORDANCE WITH THE LAWS OF FRANCE.**

**ANY DISPUTE IN RELATION TO THE INTERPRETATION OR THE EXECUTION OF THIS CONTRACT NOT AMICABLY SETTLED BETWEEN THE PARTIES WITHIN A 30 DAY PERIOD, SHALL BE SETTLED BY THE COMPETENT COURT OF ANGOULÊME (FRANCE), EVEN IN THE CASE OF INTRODUCTION OF THIRD PARTIES OR THE INVOLVEMENT OF SEVERAL DEFENDANTS. HOWEVER, THE SUPPLIER RESERVES THE EXCLUSIVE RIGHT TO BRING THE DISPUTE TO THE COMPETENT COURTS OF THE SELLER OR THE CLIENT.**



# **WORLD LEADER IN INDUSTRIAL DRIVE SYSTEMS AND ALTERNATORS**

**ELECTRIC MOTORS - GEARBOXES - ELECTRONICS  
ALTERNATORS - ASYNCHRONOUS GENERATORS - DC MACHINES**



**39 PRODUCTION UNITS  
470 SALES & SERVICE CENTRES WORLDWIDE**

MOTEURS LEROY-SOMER - Boulevard Marcellin Leroy - 16015 ANGOULEME Cedex - FRANCE  
Tél. (33) 05 45 64 45 64 - Fax (33) 05 45 64 45 04

[www.leroy-somer.com](http://www.leroy-somer.com)

# International network

www.leroy-somer.com

## ALGERIA

LEROY-SOMER International Division

## AUSTRALIA

LEROY-SOMER PTY LTD

## AUSTRIA

LEROY-SOMER ELEKTROMOTOREN

## BELGIUM

LEROY-SOMER BELGIUM

## BRAZIL

LEROY-SOMER DIVISION  
EMERSON ELECTRIC DO BRASIL Ltda.

## CANADA

LEROY-SOMER / EMC

## CHINA

LEROY-SOMER Division

## CROATIA

Emerson Network Power Ltd

## CZECH REPUBLIC

M.L.S. HOLICE S.R.O.

## DENMARK

LEROY-SOMER DENMARK A/S

## EGYPT

MOTEURS LEROY-SOMER

## FRANCE

MOTEURS LEROY-SOMER

## GERMANY

LEROY-SOMER Marbaise GmbH

## GREECE

LEROY-SOMER Ltd

## HUNGARY

LEROY-SOMER I.M.I.

## INDIA

LEROY-SOMER C/O EMERSON ELECTRIC CO.

## ITALIA

LEROY-SOMER SPA

## JAPAN

LEROY-SOMER DIVISION  
EMERSON Japan Ltd.

## KOREA

EMERSON ELECTRIC KOREA

## MOROCCO

CARREFOUR INDUSTRIEL ET TECHNOLOGIQUE

## NETHERLANDS

LEROY-SOMER NEDERLAND B.V

## POLAND

FZN MARBAISE LS

## ROMANIA

LEROY-SOMER REPRESENTATIVE OFFICE

## RUSSIA

LEROY-SOMER DIVISION

## SAUDI ARABIA

ABUNAYYAN TRADING CORPORATION

## SINGAPORE

LEROY-SOMER SOUTHEAST ASIA Pte Ltd

## SOUTH AFRICA

LEROY-SOMER PTY LTD

## SPAIN

LEROY-SOMER IBERICA S.A.

## SWEDEN

LEROY-SOMER NORDEN AB

## SWITZERLAND

LEROY-SOMER SA

## TAIWAN

LEROY-SOMER LIAISON OFFICE

## THAILAND

LEROY-SOMER THAILAND

## TUNISIA

ULYSSE SPARE PARTS

## TURKEY

ELEKTROMEKANIK SISTEMLER

## U.A.E.

LEROY-SOMER DIVISION  
EMERSON FZE

## UNITED KINGDOM

LEROY-SOMER LTD

## USA

LEROY-SOMER POWER AND DRIVES

## VENEZUELA

LEROY SOMER C/O EMERSON ELECTRIC CA



**LEROY  
SOMER**

**EMERSON**  
Industrial Automation

Leroy-Somer reserves the right to modify the characteristics of its products at any time in order to incorporate the latest technological developments.  
The information contained in this document may therefore be changed without prior notice.

338 567 258 RCS ANGOULÊME - S.A. au capital de 62 779 000 €