



**EMERSON**<sup>™</sup>  
Industrial Automation



4428 en - 2010.11 / a

 **LEROY<sup>®</sup>  
SOMER**

## **3-phase TEFV induction motors ATEX GAS - Zones 1 & 2**

Technical catalogue



## ***A WORLDWIDE GROUP AT YOUR SERVICE***

**W**ith its 10,000-strong workforce, Leroy-Somer has created an international network of 470 centres of expertise and service centres capable of offering you the technical support you need, 24 hours a day, 7 days a week throughout the world.

**T**o strengthen our commitment to the Oil and Chemicals market, Leroy-Somer has assembled a multidisciplinary team of highly qualified engineers to undertake global project management. Our R&D departments are directly involved in creating standard solutions dedicated to the new standards relating to potentially explosive atmospheres.



# 3-phase TEFV induction motors ATEX GAS - Zones 1 & 2



## Designation



The complete motor **reference** described below will enable you to **order** the desired equipment.

The selection method consists of following the terms in the designation.

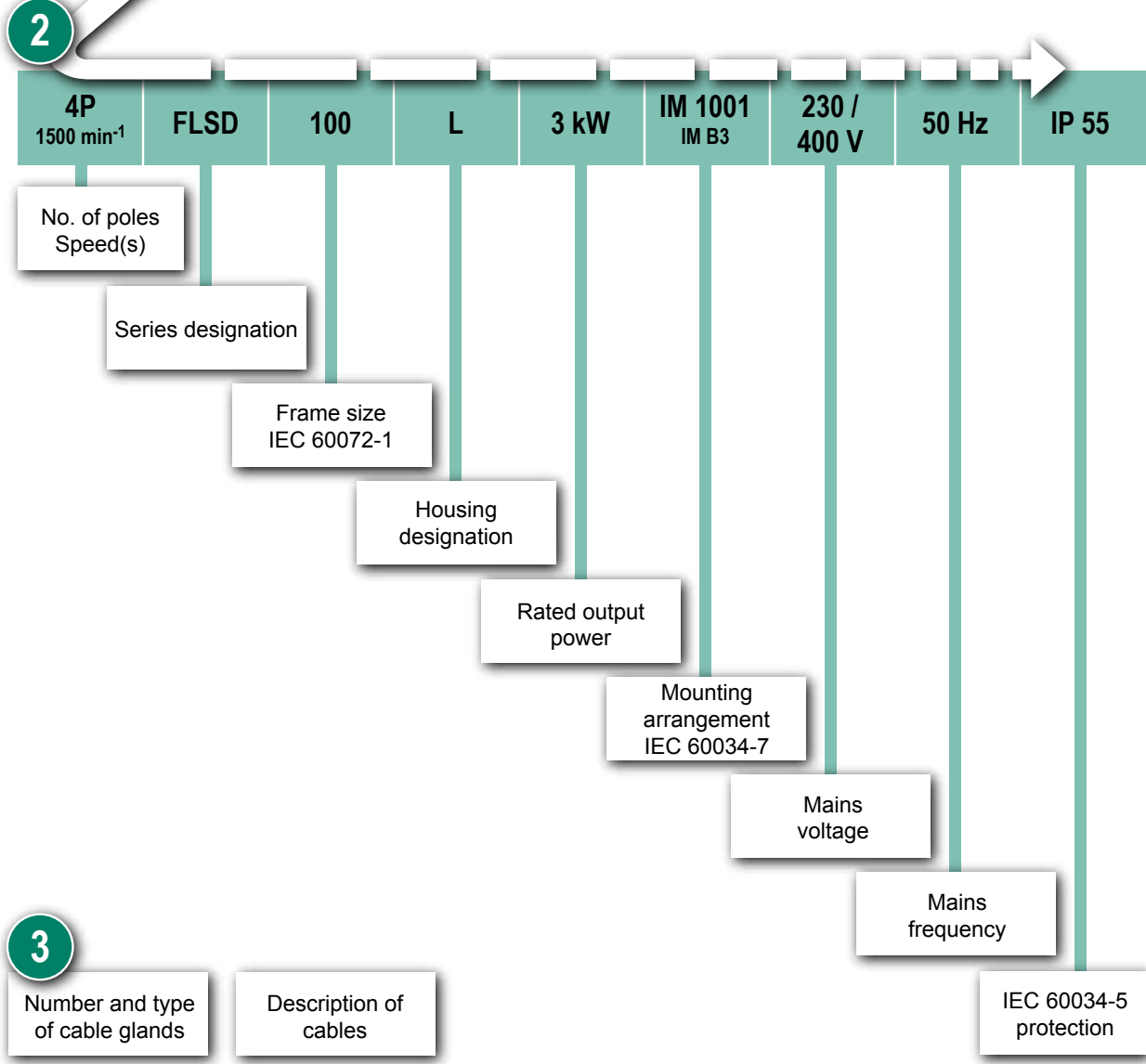

# 3-phase TEFV induction motors ATEX GAS - Zones 1 & 2



## Zone 1: II 2 G Category 2



**FLSD**  
 Cast iron frame  
 0.18 to 400 kW  
 Ex d (or de) II B T4 - Ex d (or de) II C T4  
 Flameproof induction motors  
 Complies with { EN 60079-0  
                           EN 60079-1  
                           EN 60079-7

### Other versions can also be selected:

Ex d II B T5  
 Ex d II C T5

#### Example of marking:

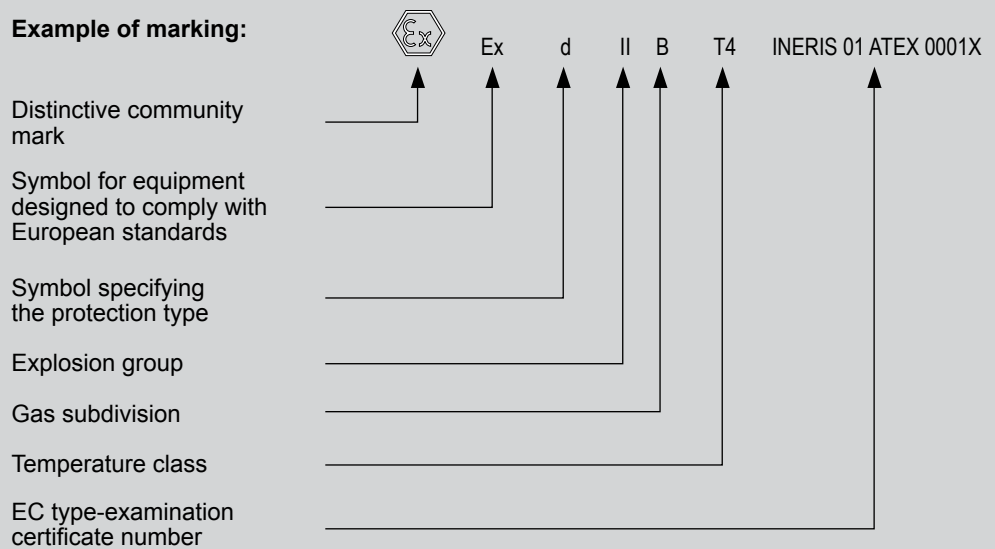

Versions also available with type "e" terminal box.



**((F)LSE**  
 Cast iron or aluminium frame  
 0.75 to 55 kW  
 Ex e II T3  
 Increased safety induction motors  
 Complies with { EN 60079-0  
                           EN 60079-7

### Other versions can also be selected:

Ex e II T3 VIK  
 Ex e II T4

# 3-phase TEFV induction motors ATEX GAS - Zones 1 & 2



## Zone 2: II 3 G Category 3

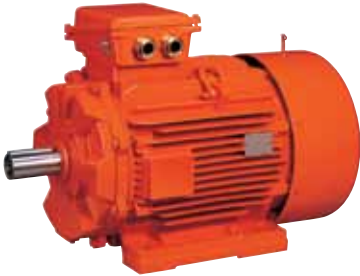

(F)LSN  
Cast iron or aluminium frame  
0.37 to 675 kW  
Ex nA II T3  
Non-sparking induction motors  
Complies with { EN 60079-0  
EN 60079-15

An nA II T3 VIK version is also available

## Gas and Dust dual environment

Complies with { EN 60079-0/EN 60079-1/EN 60079-7/EN 60079-15  
EN 61241-0/EN 61241-1

## Zone 1 + 21: II 2 GD Dual marking

FLSD	Ex d (or de) IIB T4	Ex tD A21 IP65 T125°C
FLSD	Ex d (or de) IIB T5	Ex tD A21 IP65 T100°C
(F)LSE	Ex e II T3	Ex tD A21 IP65 T125°C

## Zone 2 + 22: II 3 GD Dual marking

(F)LSN	Ex nA II T3	Ex tD A22 IP55 T125°C
--------	-------------	-----------------------

# 3-phase TEFV induction motors ATEX GAS - Zones 1 & 2



## Contents

	PAGE		PAGE
<b>A - GENERAL INFORMATION</b>		<b>C - CONSTRUCTION</b>	
Quality assurance.....	9	Description of FLSD flameproof motors: Ex d II B T4 .....	21
General standardization.....	10	Other descriptions of FLSD flameproof motors .....	22
Tolerance on main performance parameters.....	12	Variants: FLSD cast iron motors with increased safety terminal box Ex d e IIB .....	22
Definition of atmospheres and zones .....	13	FLSD cast iron motors in version Ex d IIC and Ex d e IIC ....	22
Atmospheres at risk of explosion .....	13	Description of (F)LSE increased safety motors: Ex "e" and (F)LSN non-sparking motors: Ex "nA" .....	23
Definition of hazardous areas .....	13	Mounting arrangements.....	24
Explosion group classification.....	13	Bearings and lubrication.....	25
Temperature classes.....	13	Lubrication of bearings.....	25
Classification of common gases (indicative values) .....	14	Grease life .....	27
Definition of equipment.....	15	Standard bearing fitting arrangements.....	27
Types of protection.....	15	Axial load of FLSD motors .....	28
Comparison of USA/European standards .....	15	Permissible axial load (in daN) on main shaft extension for standard bearing assembly in FLSD flameproof motors .....	28
Installation rules for surface industries .....	16	Axial load of LSE/LSN motors.....	31
Regulation relating to zones at risk of explosion caused by gas and vapours.....	16	Permissible axial load (in daN) on main shaft extension for standard bearing assembly in LSE/LSN increased safety and non-sparking motors with aluminium frame .....	31
Choice of equipment depending on the zone .....	16	Axial load of FLSE/FLSN motors .....	34
Installation technologies .....	16	Permissible axial load (in daN) on main shaft extension for standard bearing assembly in FLSE/FLSN increased safety and non-sparking motors with cast iron frame .....	34
Conditions of use.....	17	Mains connection .....	37
Normal operating conditions .....	17	Positions of the terminal box and cable gland .....	37
Motor used with frequency inverter .....	17	Power supply cables .....	38
Power correction.....	17	Number and type of adaptable cable glands on type "d" terminal box for FLSD flameproof motors.....	38
Severe environment.....	17	Type of adaptable cable glands on type "e" terminal box for FLSD flameproof - (F)LSE increased safety - (F)LSN non-sparking motors .....	38
V.I.K. version for German heavy industry .....	17	Power supply terminals - direction of rotation.....	39
		Wiring diagrams.....	39
		Earth terminals.....	39
<b>B - ENVIRONMENT</b>			
Definition of "Index of Protection" (IP/IK).....	18		
Heaters .....	19		
Space heaters.....	19		
D.C. injection .....	19		
A.C. injection.....	19		
External finish.....	20		

Copyright 2010: MOTEURS LEROY-SOMER

Leroy-Somer reserves the right to modify the characteristics of its products at any time in order to incorporate the latest technological developments.  
The information contained in this document may therefore be changed without notice.

# 3-phase TEFV induction motors

## ATEX GAS - Zones 1 & 2



### Contents

	PAGE		PAGE
<b>D - OPERATION</b>		<b>G - ELECTROMECHANICAL CHARACTERISTICS</b>	
Weighted sound level [dB(A)].....	40	<b>LSE INCREASED SAFETY - ZONE 1</b>	
Motor vibration levels - Balancing.....	41	<b>LSN NON-SPARKING - ZONE 2</b>	
<b>E - ELECTROMECHANICAL CHARACTERISTICS</b>		<b>Selection data for LSE increased safety - zone 1 .....</b>	<b>74</b>
<b>FLSD FLAMEPROOF - ZONE 1</b>		2 poles - 3000 min <sup>-1</sup> - Ex e II T3 .....	74
<b>Selection data .....</b>	<b>44</b>	4 poles - 1500 min <sup>-1</sup> - Ex e II T3 .....	75
2 poles - 3000 min <sup>-1</sup> .....	44	6 poles - 1000 min <sup>-1</sup> - Ex e II T3 .....	76
4 poles - 1500 min <sup>-1</sup> .....	45	2 poles - 3000 min <sup>-1</sup> - Ex e II T4 .....	77
6 poles - 1000 min <sup>-1</sup> .....	46	4 poles - 1500 min <sup>-1</sup> - Ex e II T4 .....	78
8 poles - 750 min <sup>-1</sup> .....	47	<b>Selection data for LSN non-sparking - zone 2 .....</b>	<b>80</b>
<b>Dimensions .....</b>	<b>48</b>	2 poles - 3000 min <sup>-1</sup> - Ex nA II T3.....	80
Shaft extensions .....	48	4 poles - 1500 min <sup>-1</sup> - Ex nA II T3.....	81
Foot mounted IM B3 (IM 1001).....	49	6 poles - 1000 min <sup>-1</sup> - Ex nA II T3.....	82
Foot and flange mounted IM B35 (IM 2001) .....	50	8 poles - 750 min <sup>-1</sup> - Ex nA II T3 .....	83
Flange mounted IM B5 (IM 3001) IM V1 (IM 3011) .....	51	<b>LSE - LSN dimensions.....</b>	<b>84</b>
Foot and face mounted IM B34 (IM 2101) .....	52	Shaft extensions .....	84
Face mounted IM B14 (IM 3601).....	53	Foot mounted IM B3 (IM 1001).....	85
<b>F - ELECTROMECHANICAL CHARACTERISTICS</b>		Foot and flange mounted IM B35 (IM 2001) .....	86
<b>FLSE INCREASED SAFETY - ZONE 1</b>		Flange mounted IM B5 (IM 3001).....	87
<b>FLSN NON-SPARKING - ZONE 2</b>		Foot and face mounted IM B34 (IM 2101) .....	88
<b>Selection data for FLSE increased safety - zone 1 .....</b>	<b>56</b>	Face mounted IM B14 (IM 3601).....	89
2 poles - 3000 min <sup>-1</sup> - Ex e II T3 .....	56	<b>H - OPTIONAL FEATURES</b>	
4 poles - 1500 min <sup>-1</sup> - Ex e II T3 .....	57	<b>Electrical options.....</b>	<b>90</b>
6 poles - 1000 min <sup>-1</sup> - Ex e II T3 .....	58	Thermal protection.....	90
2 poles - 3000 min <sup>-1</sup> - Ex e II T4 .....	59	<b>Mechanical options .....</b>	<b>91</b>
4 poles - 1500 min <sup>-1</sup> - Ex e II T4 .....	60	Terminal box .....	91
<b>Selection data for FLSN non-sparking - zone 2 .....</b>	<b>62</b>	Adaptation for vibration sensor .....	92
2 poles - 3000 min <sup>-1</sup> - Ex nA II T3.....	62	Draining of condensation .....	92
4 poles - 1500 min <sup>-1</sup> - Ex nA II T3.....	63	Tapped holes for positioning .....	92
6 poles - 1000 min <sup>-1</sup> - Ex nA II T3.....	64	Radial seal .....	92
8 poles - 750 min <sup>-1</sup> - Ex nA II T3.....	65	Forced ventilation .....	93
<b>FLSE - FLSN dimensions .....</b>	<b>66</b>	Encoders .....	93
Shaft extensions .....	66	Roller bearings.....	93
Foot mounted IM B3 (IM 1001).....	67	Flying leads.....	93
Foot and flange mounted IM B35 (IM 2001) .....	68	Non-standard flanges .....	94
Flange mounted IM B5 (IM 3001).....	69	Drip cover .....	97
Foot and face mounted IM B34 (IM 2101) .....	70		
Face mounted IM B14 (IM 3601).....	71		

# 3-phase TEFV induction motors ATEX GAS - Zones 1 & 2



## Index

PAGE	PAGE		
Altitude .....	17	Paint .....	20
Ambient temperature .....	17	Permissible axial load .....	28 to 36
Auxiliary terminal box.....	91	Potentially explosive atmospheres.....	13
<b>Balancing</b> .....	41-42	<b>Quality assurance</b> .....	9
Bearings .....	26	<b>Responsibility of the person carrying out the work</b> .....	16
<b>Cable glands</b> .....	38	<b>Space heaters</b> .....	19
Cables .....	38	Standards .....	10-11
Certification.....	9	Surface temperature .....	13
Condensation .....	92	<b>Tapped holes for positioning</b> .....	92
Connection .....	37	Terminal blocks .....	39
Connection .....	39	Terminal box .....	21 to 23-37
<b>Degree of protection</b> .....	18	Thermal protection.....	90
Dimensions.....	48 to 53-66 to 71-84 to 89	Tolerances .....	12
Direction of rotation.....	39	Types of protection.....	15
Drip cover .....	97	<b>Variable speed</b> .....	17
<b>Earth terminals</b> .....	39	Vibration .....	41-42
Earthing .....	39	Vibration sensor.....	92
Electrical and mechanical characteristics .....	43 to 89	VIK.....	17
Encoder .....	93	<b>Zones</b> .....	13-16
Environment .....	17		
Explosion groups .....	14		
<b>Fan cover</b> .....	21 to 23		
Flameproof casing .....	15-21		
Flanges.....	94 to 96		
Flying leads.....	93		
Forced ventilation .....	93		
Frequency control.....	17		
<b>Gas</b> .....	14		
Greasing.....	26		
<b>Identification</b> .....	3		
Ignition temperature.....	13-14		
Increased safety .....	15-22-23		
<b>Lifting rings</b> .....	21-23		
Lubrication .....	25-26		
<b>Marking</b> .....	4-5		
Mounting arrangements.....	24		
<b>NEC</b> .....	15		
NEMA .....	15		
Noise .....	40		
<b>Official accreditation laboratories</b> .....	9		
Operating positions.....	24		

# 3-phase TEFV induction motors ATEX GAS - Zones 1 & 2 General information



## A1 - Quality assurance

LEROY-SOMER's quality management system is based on:

- Control of procedures right from the initial sales offering until delivery to the customer, including design, manufacturing start-up and production
- A total quality policy based on making continuous progress in improving operational procedures, involving all departments in the company in order to give customer

satisfaction as regards delivery times, conformity and cost

- Indicators used to monitor procedure performance.
- Corrective actions and advancements with tools such as FMECA, QFD, MAVP, MSP/MSQ and Hoshin type improvement workshops on flows, process re-engineering, plus Lean Manufacturing and Lean Office.

- Annual surveys, opinion polls and regular visits to customers in order to ascertain and detect their expectations.

Personnel are trained and take part in the analyses and actions for continuously improving the procedures.

LEROY-SOMER has entrusted the certification of its expertise to various international organisations.

Certification is granted by independent professional auditors, and recognises the high standards of the company's **quality assurance procedures**.

All activities resulting in the final version of the machine have therefore received official certification **ISO 9001: 2000 from the DNV**.

Similarly, our environmental approach has enabled us to obtain certification ISO 14001: 2004.

Products for particular applications or those designed to operate in specific environments are also approved or certified by the following organisations: INERIS, LCIE, DNV, BSRIA, TUV, CCC, GOST, which check their technical performance against the various standards or recommendations.



ISO 9001 : 2000



### CERTIFICATION

The ATEX motors presented in this catalogue comply with the national and/or international standards governing the construction of this type of equipment.

EC type-examination certificates are drawn up by notified bodies, **in accordance with the European Community Council Directive 94/9/EC known as ATEX**.

Approval is obtained when descriptive documents have been examined and validated, and tests performed. These include tests involving heating and explosion of the equipment.

EC-type examination certificates granted by the bodies listed opposite are recognized by all EC countries.

Approved equipment is authorized to carry the CE mark or the distinctive community mark

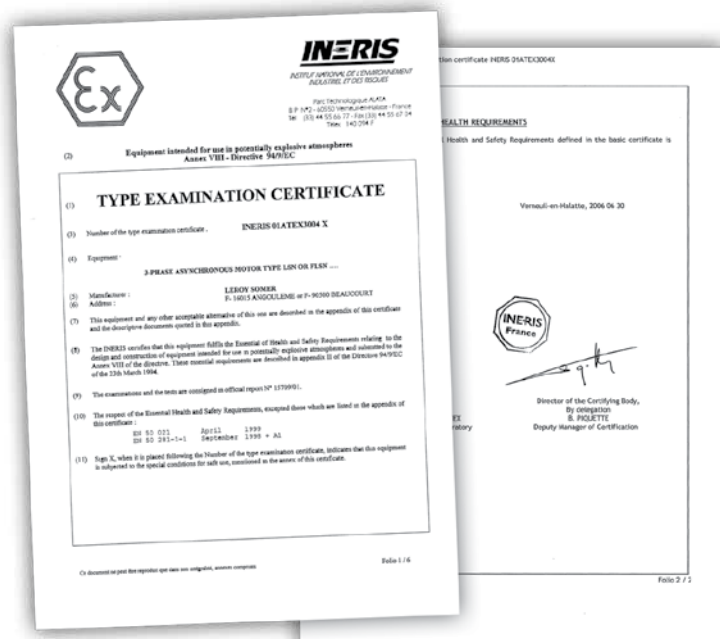



# 3-phase TEFV induction motors ATEX GAS - Zones 1 & 2 General information



## A2 - General standardization

### ORGANIZATION OF STANDARDS AUTHORITIES

#### International bodies

<p><b>Worldwide</b></p> 	<p>General standardization</p> <p><b>ISO</b> International Standards Organisation</p> <div style="display: flex; justify-content: space-around;"> <div style="border: 1px solid black; padding: 2px; text-align: center;">TC Committees technical</div> <div style="border: 1px solid black; padding: 2px; text-align: center;">SC Sub- committees</div> <div style="border: 1px solid black; padding: 2px; text-align: center;">WG Working groups</div> </div>	<p>Electronics/electrotechnical standardization</p> <p><b>IEC</b> International Electrotechnical Commission</p> <div style="display: flex; justify-content: space-around;"> <div style="border: 1px solid black; padding: 2px; text-align: center;">TC Committees technical</div> <div style="border: 1px solid black; padding: 2px; text-align: center;">SC Sub- committees</div> <div style="border: 1px solid black; padding: 2px; text-align: center;">WG Working groups</div> </div>
<p><b>European</b></p> 	<p><b>CEN</b> European Committee for Standards</p> <p><b>ECISS</b> European Committee for Iron and Steel Standardization</p> <div style="border: 1px solid black; padding: 2px; text-align: center; margin: 10px auto; width: 100px;">TC Technical committees</div>	<p><b>CENELEC</b> European Committee for Electrotechnical Standardization</p> <div style="display: flex; justify-content: space-around; margin-top: 10px;"> <div style="border: 1px solid black; padding: 2px; text-align: center;">TC Technical committees</div> <div style="border: 1px solid black; padding: 2px; text-align: center;">SC Sub- committees</div> <div style="border: 1px solid black; padding: 2px; text-align: center;">AHG Ad hoc groups</div> </div>

# 3-phase TEFV induction motors ATEX GAS - Zones 1 & 2 General information



## A2 - General standardization

### List of standards quoted in this document

References	International standards	
IEC/EN 60034-1	Electrical rotating machines: ratings and operating characteristics.	
IEC/EN 60034-5	Electrical rotating machines: classification of degrees of protection provided by casings of rotating machines.	
IEC/EN 60034-6	Electrical rotating machines (except traction): cooling methods.	
IEC/EN 60034-7	Electrical rotating machines (except traction): symbols for mounting positions and assembly layouts.	
IEC 60034-8	Electrical rotating machines: terminal markings and direction of rotation.	
IEC/EN 60034-9	Electrical rotating machines: noise limits.	
IEC/EN 60034-12	Starting characteristics for single-speed three-phase cage induction motors for supply voltages less than or equal to 660 V.	
IEC/EN 60034-14	Electrical rotating machines: mechanical vibrations of certain machines with a frame size above or equal to 56 mm. Measurement, evaluation and limits of vibrational intensity.	
IEC 60034-2	Electrical rotating machines: methods for determining losses and efficiency from tests (additional losses added as a fixed percentage).	
IEC 60034-2-1	Electrical rotating machines: methods for determining losses and efficiency from tests (measured additional losses).	
IEC 60034-30	Electrical rotating machines: efficiency classes for single-speed three-phase cage induction motors (IE code).	
IEC 60038	IEC standard voltages.	
IEC 60072-1	Dimensions and power series for electrical rotating machines: designation of casings between 56 and 400 and flanges between 55 and 1080.	
IEC 60085	Evaluation and thermal classification of electrical insulation.	
IEC/EN 60529	Degrees of protection provided by enclosures.	
IEC 60721-2-1	Classification of natural environment conditions. Temperature and humidity.	
IEC 60892	Effects of an imbalance in the voltage system on the characteristics of three-phase squirrel-cage induction motors.	
IEC/EN 61000-2-2	Electromagnetic compatibility (EMC): environment.	
IEC guide 106	Guidelines on the specification of environmental conditions for the determination of operating characteristics of equipment.	
ISO 281	Bearings - Basic dynamic loadings and nominal bearing life.	
ISO/EN ISO 1680	Acoustics - Test code for measuring airborne noise emitted by electrical rotating machines: a method for establishing an expert opinion for free field conditions over a reflective surface.	
ISO 8821	Mechanical vibration - Balancing. Conventions on shaft keys and related parts.	
EN 60529	Degree of protection provided by electrical enclosures against extreme mechanical impacts.	
New Ref.	Old Ref.	
EN 60079-0	EN 50014	Electrical equipment for explosive atmospheres: general regulations.
EN 60079-1	EN 50018	Electrical equipment for explosive atmospheres: "d" flameproof casings.
EN 60079-7	EN 50019	Electrical equipment for potentially explosive atmospheres: "e" increased safety.
EN 60079-14		Electrical installations in hazardous areas.
EN 60079-15	EN 50021	Electrical equipment for explosive atmospheres: "n" non-sparking.
EN 61241-0 & 1	EN 50281-1-1	Electrical apparatus for use in the presence of combustible dust.

# 3-phase TEFV induction motors ATEX GAS - Zones 1 & 2 General information



## A3 - Tolerance on main performance parameters

### Tolerances on electromechanical characteristics

IEC 60034-1 specifies standard tolerances for electromechanical characteristics.

Parameters	Tolerances
Efficiency $\left\{ \begin{array}{l} \text{machines } P \leq 150 \text{ kW} \\ \text{machines } P > 150 \text{ kW} \end{array} \right.$	$- 15\% (1 - \eta)$ $- 10\% (1 - \eta)$
Cos $\varphi$	$- 1/6 (1 - \cos \varphi)$ (min 0.02 - max 0.07)
Slip $\left\{ \begin{array}{l} \text{machines } P < 1 \text{ kW} \\ \text{machines } P \geq 1 \text{ kW} \end{array} \right.$	$\pm 30\%$ $\pm 20\%$
Locked rotor torque	$- 15\%, + 25\%$ of rated torque
Starting current	$+ 20\%$
Run-up torque	$- 15\%$ of rated torque
Maximum torque	$- 10\%$ of rated torque $> 1.6 M_N$
Moment of inertia	$\pm 10\%$
Noise	$+ 3 \text{ dB (A)}$
Vibration	$+ 10\%$ of the guaranteed class

Note: - IEC 60034-1 does not specify tolerances for current  
- the tolerance is  $\pm 10\%$  in NEMA-MG1

### Tolerances and adjustments

The standard tolerances shown below are applicable to the mechanical characteristics given in our catalogues. They comply fully with the requirements of IEC standard 60072-1.

Characteristics	Tolerances
Frame size H $\leq 250$ $\geq 280$	$0, - 0.5 \text{ mm}$ $0, - 1 \text{ mm}$
Diameter $\varnothing$ of the shaft extension: - 11 to 28 mm - 32 to 48 mm - 55 mm and over	<b>j6</b> <b>k6</b> <b>m6</b>
Diameter N of flange spigots	<b>j6 up to FF 500,</b> <b>js6 for FF 600 and over</b>
Key width	<b>h9</b>
Width of drive shaft keyway (normal keying)	<b>N9</b>
Key depth: - square section - rectangular section	<b>h9</b> <b>h11</b>
① <b>Eccentricity of shaft in flanged motors</b> <b>flanged</b> (standard class) - diameter > 10 up to 18 mm - diameter > 18 up to 30 mm - diameter > 30 up to 50 mm - diameter > 50 up to 80 mm - diameter > 80 up to 120 mm	<b>0.035 mm</b> <b>0.040 mm</b> <b>0.050 mm</b> <b>0.060 mm</b> <b>0.070 mm</b>
② <b>Concentricity of spigot diameter</b> and ③ <b>perpendicularity of mating surface of flange in relation to shaft</b> (standard class) Flange (FF) or Faceplate (FT): - F 55 to F 115 - F 130 to F 265 - FF 300 to FF 500 - FF 600 to FF 740 - FF 940 to FF 1080	<b>0.08 mm</b> <b>0.10 mm</b> <b>0.125 mm</b> <b>0.16 mm</b> <b>0.20 mm</b>

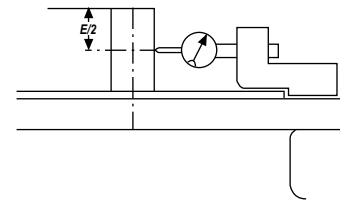

① Eccentricity of shaft in flanged motors

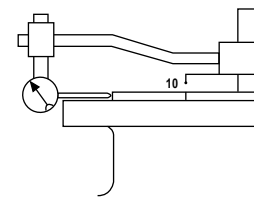

② Concentricity of spigot diameter

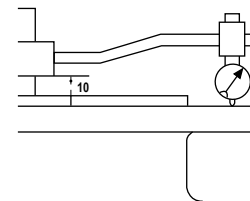

③ Perpendicularity of mating surface of flange in relation to shaft

# 3-phase TEFV induction motors

## ATEX GAS - Zones 1 & 2

### General information



## A4 - Definition of atmospheres and zones

### A4.1 - ATMOSPHERES AT RISK OF EXPLOSION

This includes all explosive and potentially explosive conditions, the explosion character being permanent or potential.

#### Explosive atmospheres:

An explosive atmosphere is an atmosphere containing a mixture of air and inflammable substances (in the form of gas, vapour, fog or mist) in such proportions that excessive temperature, arcs or sparks cause it to explode. **The danger is permanent.**

#### Potentially explosive atmospheres:

A potentially explosive atmosphere is an atmosphere which may become explosive due to the particular local conditions. **The danger is potential.**

### A4.2 - DEFINITION OF ZONES AT RISK OF EXPLOSION

The international standard EN 60079-10 defines the danger zones according to the risk of encountering an explosive atmosphere as shown in the diagram opposite:

- Zone 0:** location where an explosive gaseous atmosphere is permanently present for long periods.
- Zone 1:** location where an explosive gaseous atmosphere is likely to develop during normal operation.
- Zone 2:** location where an explosive gaseous atmosphere is not likely to form during normal operation, and where such a development, should it occur, only lasts for a short period of time.

Note: Each country has similar and complementary publications giving instructions on the classification of dangerous areas.

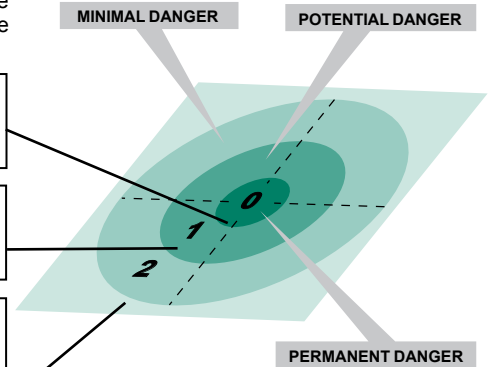

Note: Zone classification is the responsibility of the manager of the company where the equipment is installed.

### A4.3 - EXPLOSION GROUP CLASSIFICATION

#### A4.3.1 - Area levels

The areas presenting explosion risks are divided into 2 groups:

- **Group I:** Gas-prone mines.
- **Group II:** Areas other than gas-prone mines (**surface industries**).

**This catalogue only concerns equipment in group II.**

#### A4.3.2 - Gas classification

- Group I: Only applies to mine gas (methane in mines).
- Group II: The gases present are classified in **3 subdivisions A, B and C.**

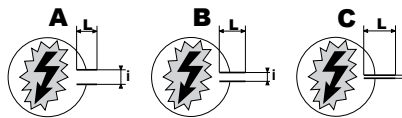

The A, B, C classification is defined according to the MESG (Maximum Experimental Safe Gap) which characterises the ability of a gas not to propagate ignition through a standard joint. **The risks following an explosion increase from subdivision A to subdivision C.**

Therefore, equipment certified for use in the presence of a type C gas can also be used in the presence of a type A or B gas.

### A4.4 - TEMPERATURE CLASSES

#### A4.4.1 - Definition of temperature classes according to IEC 60079-0

The temperature class is based on the maximum temperature rise in the equipment and on the ambient operating temperature.

The maximum surface temperature of an electrical appliance must always be lower than the ignition temperature of the mix of gases or vapour in which it will be used.

In order to be able to select various appliances according to their surface temperature, **six temperature classes** have been created.

Temperature class	T1	T2	T3	T4	T5	T6
Ignition temperature	> 450°C	> 300°C	> 200°C	> 135°C	> 100°C	> 85°C
Max. permissible surface temperature for the equipment	450°C	300°C	200°C	135°C	100°C	85°C

#### A4.4.2 - Definition of temperature classes according to IEC 60079-7 for Ex e

- $T^{\circ}C$  = temperature
  - $\Delta T$  at  $P_N$  = temperature at rated power
  - $t_s$  = time
  - $t_E$  = locked rotor time
  - (A) = temperature rise in normal duty
  - (B) = temperature rise during locked rotor test
- In the event of rotor failure and locking, an actuator must be able to disconnect the motor from the supply in a period  $t < t_E$ .

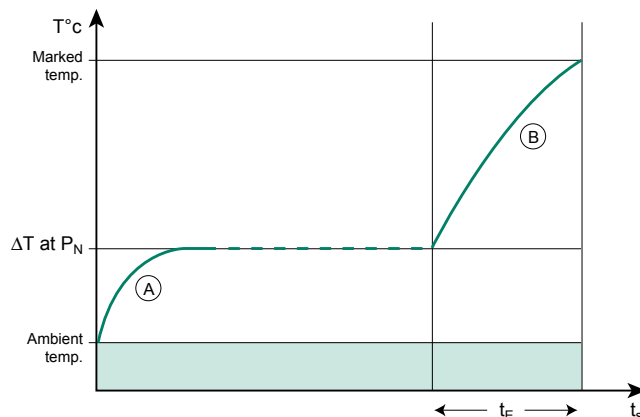

# 3-phase TEFV induction motors

## ATEX GAS - Zones 1 & 2

### General information



## A5 - Classification of common gases (indicative values)

Gas	Ignition temperature °C	Equipment temperature class	Explosion group
Acetic acid	464	T1	IIA
Acetic anhydride	316	T2	IIA
Acetone	465	T1	IIA
Acetylene	305	T2	IIC
Ammonia solution	630	T1	IIA
Amyl acetate	380	T2	IIA
Benzene (pure)	498	T1	IIA
Butane n	365	T2	IIA
Butanol n	343	T2	IIA
Carbon disulphide	95	T6	IIC
Carbon monoxide	605	T1	IIB
Cyclohexanon	420	T2	IIA
Dichlorethylene	460	T1	IIA
Diesel oil DIN 51601/04.78	220 to 300	T3	IIA
Ethanal	140	T4	IIA
Ethane	472	T2 - T1	IIA
Ethyl acetate	427	T2	IIA
Ethyl alcohol	425	T2	IIA - IIB
Ethyl chloride	510	T1	IIA
Ethylene	425	T2	IIB
Ethylene glycol	235	T3	IIB
Ethylene oxide	440	T2	IIB
Ethylic ether	180	T4	IIB
Fuel EL DIN 51 603 section 1/12.81	220 to 300	T3	IIA
Fuel L DIN 51 603 section 2/10.76	220 to 300	T3	IIA
Fuels M and S DIN 51 603 section 2/10.76	220 to 300	T3	IIA
Hexane n	225	T3	IIA
Hydrogen	560	T1	IIC
Hydrosulphuric acid	270	T3	IIB
Kerosene (or fuel oil no. 1)	220 to 300	T3	IIA
Methane	537	T1	IIA
Methanol	385	T2	IIA
Methylene chloride	625	T1	IIA
Naphthalene	520	T1	IIA
Oils for motors with boiling point < 135°C	220 to 300	T3	IIA
Oleic acid	360	T2	IIB
Phenol	595	T1	IIA
Propane	450	T2	IIA
Propylene alcohol	405	T2	IIB
Special oils with boiling point < 135°C	220 to 300	T3	IIA
Tetraline (tetrahydronaphthalene)	425	T2	IIB
Toluene	482	T1	IIA
Town gas	560	T1	IIB

# 3-phase TEFV induction motors ATEX GAS - Zones 1 & 2 General information



## A6 - Definition of equipment

### A6.1 - TYPES OF PROTECTION

European standards define, according to the selected type of protection, construction rules for electrical equipment which can be used in potentially explosive conditions.

These protection methods each form a specific standard in addition to the EN 60079-0 standard (general rules) and are indicated by a lower case letter.

These are:

- d: Flameproof enclosure
- e: Increased safety
- nA: Non-sparking
- p: Pressurized enclosure
- q: Powder filling
- o: Immersion in oil
- i: Fail safe
- m: Encapsulating

#### A6.1.1 - Electric motors protected by type "d" flameproof enclosure (EN 60079-1)

They must satisfy, among others, the following requirements:

- Resist an internal explosion of the air/gas mixture without damage to or permanent distortion of the enclosure.
- Ensure that the ignition inside the enclosure cannot be transmitted to the ambient explosive atmosphere.
- Present a surface temperature lower than the ignition temperature of the gas.

These three conditions require:

- Very robust construction of the enclosure.
- Minimum joint lengths and reduced gaps so that explosion of the air/gas mixture that is present inside the enclosure is not transmitted to the ambient potentially

explosive atmosphere (end shield/housing recesses, shaftways, etc).

- Limited temperature rise, taking into account unfavourable operating conditions (voltage limits) ensuring, depending on the ambient temperature, a surface temperature that is lower than the temperature class required by the type of gas present.

#### A6.1.2 - Electric motors protected by type "e" increased safety enclosure (EN 60079-7)

The type "e" protection method concerns equipment which does not produce arcs, sparks or hot spots during normal operation. This excludes in particular all rotating machines with a commutator.

This requires, amongst others, the following design features:

- Special precautions to avoid the production of arcs and sparks: air distances, and minimum creepage distances between items which are powered up and, with regard to earths, absence of mechanical friction, insulation, minimum distances in ventilation systems, special materials for fans, etc.
- Temperature at all points in the motor lower than the ignition temperature of the gas. This temperature must include a period with the rotor locked as defined in standard EN 60079-7.

#### A6.1.3 - "nA" non-sparking electric motors (EN 60079-15)

The type "nA" protection method concerns equipment which generates no sparks, arcs, or hot spots, which operates in an exceptionally explosive atmosphere.

### A6.2 - COMPARISON OF USA/EUROPEAN STANDARDS

The installation regulations which apply in the USA are those specified in the NEC (National Electrical Code).

There is no mutual recognition between NEC and EN standards.

However, American firms in Europe or the Middle East often refer to the NEC, and it is therefore important to be able to translate these standards:

NEC		CENELEC
Class I	Gas	Group/Category II
Class II	Dust	Group/Category II
Class III	Fibre	No specific standard
Division (DIV) I		Zone 0, 1 or 21
Division (DIV) II		Zone 2 or 22
Group A	Acetylene	II C
Group B	Hydrogen	II C
Group C		II B
Group D		II A

Motors which have been granted ATEX certification by INERIS cannot be used in the USA and Canada.

# 3-phase TEFV induction motors

## ATEX GAS - Zones 1 & 2

### General information



## A7 - Installation rules for surface industries

### A7.1 - REGULATION RELATING TO ZONES AT RISK OF EXPLOSION CAUSED BY GAS AND VAPOURS

In zones at risk of explosion, electrical installations must be reduced to what is essential to the operating needs. Equipment, motors, ducting, necessary communication devices must, as far as possible, be placed outside the danger zones.

**European Directive ATEX 94/9/EC**, concerning electrical installations of plant classified as being likely to **present risks of explosion, requires in particular that the worker in an establishment:**

- **Defines the zones where explosive atmospheres may appear.**
- **Selects electrical equipment suitable for the previously defined zones.**
- **Checks the conditions of installation, operation and maintenance of this equipment.**

The standard EN 60079-10 can be used to determine dangerous regions.

### A7.2 - CHOICE OF EQUIPMENT DEPENDING ON THE ZONE

Although harmonised construction standards exist, there is no coordinated regulation for the choice of equipment according to the zone (0, 1, 2) where it is installed, even though there is an EN 60079-0 recommendation.

Nevertheless it can be said that:

#### Zone 0:

The entire installation must be built with fail safe category "ia". Only control or measurement equipment can be installed there.

#### Zone 1:

All electrical equipment used in zone 1 must be "safe", in other words it must conform to standard 60079.

This equipment should be installed in accordance with the current rules and regulations. If "d" flameproof equipment is authorized for all countries, "e" increased safety equipment may be either totally or partially accepted.

In particular:

- France, Germany, Holland = totally accepted
- Belgium: partially (mains box but not motors)

#### Zone 2:

The equipment which can be used in zone 2 must be equipment that satisfies one of the two following conditions:

- Meets the rules for zone 1 equipment
- Conforms with the construction rules of a recognized standard for industrial electrical equipment which, during normal operation, does not generate arcs, sparks or hot surfaces which may cause ignition or an explosion. It can for instance conform to the English standard BS 5000 part 16 or to IEC 79.15. In this case, the equipment can be accompanied by a document issued by an official laboratory, or by a declaration of conformity from the manufacturer.

**In all cases it is necessary to take account of the particular specifications and the internal safety rules for each industry in each country.**

### A7.3 - INSTALLATION TECHNOLOGIES

For installing electrical motors protected by "d" flameproof enclosures in zones at risk of explosion, there are three types of connection.

1. Direct entry of cables into the "d" flameproof enclosure via cable inlets of an approved type.
2. Indirect entry of cables via an "e" increased safety junction box.
3. Direct entry of cables into the "d" flameproof enclosure via tubes of an approved type ("conduit" system mainly used in the United States).

See EN 60079-14.

# 3-phase TEFV induction motors ATEX GAS - Zones 1 & 2 General information



## A8 - Operating conditions

### A8.1 - NORMAL OPERATING CONDITIONS

a/ According to IEC 60034-1, motors can operate in the following normal conditions:

- ambient temperature within the range -16 to +40°C
- altitude less than 1000 m
- atmospheric pressure: 1050 hPa (mbar)

Standard EN 60079-0 concerning electrical equipment in a potentially explosive atmosphere extends the range of ambient temperatures from -20 to +40°C as standard. In this case, no additional marking is necessary on the certified equipment.

Temperatures outside this range may be considered when the equipment is certified. An additional mark must therefore be added. These extensions involve special consultation.

b/ FLSD motors are designed to operate in atmospheres where the relative humidity can reach 95% at 40°C.

### A8.2 - MOTOR USED WITH FREQUENCY INVERTER

The certification of our safety motors makes them suitable for use with frequency inverters, as long as all necessary precautions are taken to comply with the temperature class for which they were certified, in all circumstances.

Drive control by a frequency inverter can in fact result in an increase in the machine temperature rise, mainly due to the reduction in speed of the cooling fan and a significantly lower supply voltage than on the mains.

To ensure safety, the motors must be fitted with thermal winding probes and a DE end shield probe for frame sizes of 160 mm or higher.

In addition, the motor rated power should usually be reduced. Derating tables have been drawn up by our design offices on the basis of on-load tests conducted on a test bed and by the specifications of IEC 60034-17. Depending on the application, the desired speed range and the torque profile of the driven machine, Leroy-Somer will select the most suitable safety motor. Inverters of a type not designed for operation in a potentially explosive zone must be placed in a non-explosive zone.

For (F)LSE increased safety and (F)LSN non-sparking protection modes, a motor, of exactly the same type, must be tested on-load with a frequency inverter with identical characteristics and marks to the one it will be used with.

In some cases, it may prove necessary to use an ATEX-approved forced ventilation unit. For small motors (frame size below 160), the self-cooled standard cooling method (IC411) is nonetheless to be preferred.

A device to measure the actual motor speed, using an ATEX-certified incremental or absolute encoder, can also be installed at the non-drive end of most of our safety motors.

### A8.3 - POWER CORRECTION

The power ratings of our motors are given for continuous duty (S1) at rated voltage and frequency, at up to 1000 m altitude and at a maximum ambient temperature of 40°C as standard.

By derating their rated power, it is possible to use our ATEX motors in temperature conditions above 40°C (max. 60°C) and at higher altitudes than 1000 m.

heavy industry which apply to equipment for potentially explosive atmospheres. The main characteristics with which motors manufactured in accordance with this recommendation must comply are:

- Finish for corrosive environment (paint, screws and bolts, etc).
- Two stainless steel nameplates, one located inside the terminal box.
- Terminal box seal glued to the lid.
- Drip cover if motor placed in vertical position, shaft end facing down.
- For increased safety motors, a permissible locked rotor time, defined in the recommendation, longer than the standard.

Table of correction coefficients\*

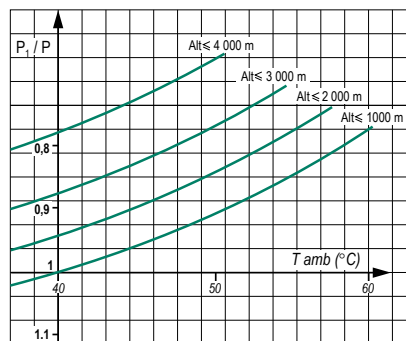

\* For FLSD Ex d(e) IIB or IIC T4, (F)LSN Ex nA II T3 and (F)LSE Ex e II T3 motors.

For (F)LSE Ex e II T4 motors as well as for FLSD Ex d(e) IIB and IIC T5 motors, please consult Leroy-Somer on a case-by-case basis.

### A8.4 - SEVERE ENVIRONMENT

Some operating conditions require special finishes for the environment: very dusty, humid, or harsh atmospheres.

The essential criteria for anti-corrosion protection apply to custom components meeting the requirements of the ATEX Directive (screws and bolts, plates, cover), metal cable glands, protection of working parts (stator and rotor), special finishes.

### A8.5 - V.I.K. VERSION FOR THE GERMAN HEAVY INDUSTRY

ATEX Ex d e IIC T4, Ex e II T3 and Ex nA II T3 motors can be built to comply with the V.I.K. recommendations issued by German











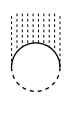
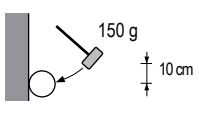

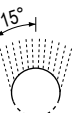
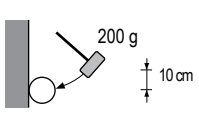
# 3-phase TEFV induction motors ATEX GAS - Zones 1 & 2 Environment

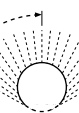
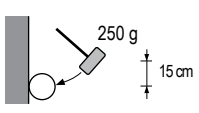
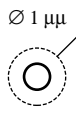

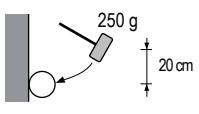
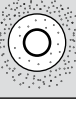
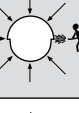
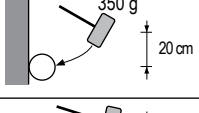
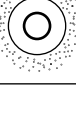
## B1 - Definition of "Index of Protection" (IP/IK)

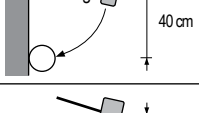
In standard configuration Leroy-Somer ATEX motors are IP 55 and IK 08 \*

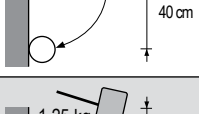
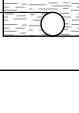
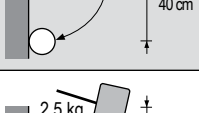
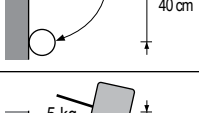
Indices of protection of electrical equipment enclosures  
In accordance with IEC 60034-5 - EN 60034-5 (IP) - EN 50102 (IK)

1st number: Protection against solid objects			2nd number: Protection against liquids			Mechanical protection		
IP	Tests	Definition	IP	Tests	Definition	IK	Tests	Definition
0		No protection	0		No protection	00		No protection
1		Protected against solid objects larger than 50 mm (e.g. accidental contact with the hand)	1		Protected against water drops falling vertically (condensation)	01		Impact energy: 0.15 J
2		Protected against solid objects larger than 12 mm (e.g. a finger)	2		Protected against water drops falling at up to 15° from the vertical	02		Impact energy: 0.20 J
3		Protected against solid objects larger than 2.5 mm (e.g. tools, wires)	3		Protected against rain falling at up to 60° from the vertical	03		Impact energy: 0.37 J
4		Protected against solid objects larger than 1 mm (e.g. thin tools, small wires)	4		Protected against projected water from all directions	04		Impact energy: 0.50 J
5		Protected against dust (no deposits of harmful material)	5		Protected against jets of water from all directions from a hose	05		Impact energy: 0.70 J
6		Totally protected against any dust penetration	6		Protected against projected water comparable to big waves	06		Impact energy: 1 J
			7		Protected against the effects of immersion between 0.15 and 1 m	07		Impact energy: 2 J
			8		Protected against prolonged effects of immersion under pressure	08		Impact energy: 5 J
						09		Impact energy: 10 J
						10		Impact energy: 20 J

Example:

Example of a machine IP 55

IP: Index of protection

5 : Machine protected against dust and accidental contact.

Test result: **no dust enters** in harmful quantities, no risk of direct contact with rotating parts. The test will last for 2 hours.

.5 : Machine protected against jets of water from all directions from hoses at 3 m distance with a flow rate of 12.5 l/min at 0.3 bar.

The test will last for 3 minutes. Test result: **no damage from water** projected onto the machine.

\* Other versions available: IP65 (GD), IP56, IP66, IK10 with prior consultation.

# 3-phase TEFV induction motors ATEX GAS - Zones 1 & 2 Environment



## B2 - Heaters

### B2.1 - SPACE HEATERS

Severe climatic conditions, e.g.  $T_{amb} < -40^{\circ}\text{C}$ ,  $\text{RH} > 95\%$  etc, may require the use of space heaters (fitted to the motor windings) which serve to maintain the average temperature of the motor, provide trouble-free starting, and eliminate problems caused by condensation (loss of insulation).

The heater supply wires are brought out to a terminal block in the motor terminal box. The heaters must be switched off while the motor is running.

Frame size	Power (W)				
	Non-sparking		Increased safety		Flameproof
	LSN	FLSN	LSE	FLSE	FLSD
80	10	25	10	25	25
90 to 132	25	25	25	25	25
160 MP/LR	25	-	25	-	-
160 M/L to 200	50	50	50	-	50
225 ST/MT	50	50	50	50	-
225 MR/MG	50	-	50	-	-
225 S/M	-	80	-	80	100
250 MZ	50	-	50	-	-
250 ME	80	-	80	-	-
250 M	-	80	-	-	100
280 SC/MC/MD	80	-	80	-	-
280 S/M	-	100	-	-	100
315 S/ST/M/L (A,B)	-	100	-	-	100
355 L (A,B,C,D)	-	150	-	-	150

### B2.2 - D.C. INJECTION

An alternative to the use of space heaters is to inject direct current into two of the phases wired in series from a D.C. voltage source which can give the total power indicated in the table above. This method can only be used on motors rated less than 10 kW.

This is easily calculated: if R is the resistance of the windings in series, the D.C. voltage will be given by the equation (Ohm's law):

$$U_{(V)} = \sqrt{P_{(W)} \cdot R_{(\Omega)}}$$

Resistance should be measured with a micro-ohmmeter.

### B2.3 - A.C. INJECTION

A single-phase A.C. voltage (10 to 15% of rated voltage) can be used between 2 phases placed in series.

This method can be used on the whole ATEX range.

# 3-phase TEFV induction motors ATEX GAS - Zones 1 & 2 Environment



## B3 - External finish

LEROY-SOMER motors are protected with a range of surface finishes.  
The surfaces receive appropriate special treatments, as shown below.

The polyvinyl butyral undercoat acts as a primer and base coat from frame size 160 mm.

Surface	Surface treatment
Cast iron	SA 2.5 shot blasting Application of a primer (25 to 30 µm) or a coat of polyvinyl 20 µm or epoxy ester
Steel	Phosphatization + Primer Electrostatic painting or epoxy powder
Aluminium alloy	Shot blasting

### Definition of atmospheres

An atmosphere is said to be harsh when components are attacked by bases, acids or salts. It is said to be corrosive when components are attacked by oxygen.

### Paint systems

Products	Environment	System	Applications	Corrosivity category acc. to ISO 12944-2
Increased safety - Non-sparking  Aluminium frame: LSE - LSN	Non-harsh and not very harsh (indoors, rural or industrial)	Ia	1 polyurethane top coat, 20/30 µm	C3L
	Substantial chemical attack: frequent contact with bases, acids, alkalis neutral environment (not in contact with chlorinated or sulphurous products)	IIIb	1 Epoxy base coat, 30/40 µm 1 Epoxy intermediate coat, 30/40 µm 1 Epoxy top coat, 25/35 µm	C4H
Increased safety - Non-sparking - Flameproof  Aluminium frame: LSE - LSN  Cast iron frame: FLSE - FLSN - FLSD	Moderately corrosive: damp and outdoors (temperate climate)	IIa	1 Epoxy base coat, 30/40 µm 1 polyurethane top coat, 20/30 µm	C3M
	Corrosive: coastal, very humid (tropical climate)	IIIa	1 Epoxy base coat, 30/40 µm 1 Epoxy intermediate coat, 30/40 µm 1 polyurethane top coat, 20/30 µm	C4M
	Special conditions Very harsh, polluted with chlorinated or sulphurous products	IVb  161a/b	1 base coat, 20/30 µm 2 Epoxy intermediate coats, each 35/40 µm 1 Epoxy top coat, 35/40 µm  1 base coat, 50 µm 2 Epoxy intermediate coats, each 80 µm 1 Epoxy top coat, 50 µm	C5I  C5M

System Ia as standard for motors with aluminium frame: LSN - LSE

System IIa as standard for motors with cast iron frame: FLSN - FLSE - FLSD

Some application conditions require special finishes for the environment:

- **extremely harsh environments (chemical industries, refineries, etc):**

paint system IIIa, steel screws with anti-corrosion coating, stainless steel cover (optional).

The standard paint colour for the ATEX Gas range is: **RAL 2004**

# 3-phase TEFV induction motors ATEX GAS - Zones 1 & 2 Construction



## C1 - Description of FLSD flameproof motors: Ex d II B

Component	Materials	Remarks
1 Finned housing	Cast iron	- with integral feet or without feet • 4, 6 or 8 fixing holes for foot mounting • lifting rings for frame size $\geq 90$ - external earth terminal
2 Stator	Insulated low-carbon magnetic steel laminations Insulated electroplated copper	- low carbon content guarantees long-term lamination pack stability - semi-enclosed slots - class F insulation
3 Rotor	Insulated low-carbon magnetic steel laminations Aluminium (A5L) or copper	- squirrel cage with inclined cage bars - rotor cage pressure die-cast in aluminium (or alloy for special applications) or soldered in copper - shrink-fitted to shaft or keyed - rotor balanced dynamically, class A - 1/2 key
4 Shaft	Steel	- for frame size $\leq 132$ : • tapped shaft end • closed keyway - for frame size $\geq 160$ : • tapped shaft end • open keyway
5 End shields	Cast iron	
6 Bearings and lubrication		- bearings preloaded at NDE from 80 to 315 ST and preloaded at DE from 315 M upwards
7 Labyrinth seal Lipseals	Plastic or steel Synthetic rubber	- lipseal or labyrinth seal at drive end and seal at non drive end for frame sizes up to 225 inclusive and 280 - decompression grooves for frame sizes 250 - 315 and 355
8 Fan	Composite material up to frame size 225 inclusive, metal for larger models	- 2 directions of rotation: straight blades
9 Fan cover	Pressed steel	- fitted with a drip cover for operation in vertical position outdoors, shaft end facing down
10 Terminal box	Cast iron Steel for frame size 280	- type "d" in standard version and type "e" as an option (section C2.1) - fitted with a flameproof cable gland (cable $\varnothing$ must be specified at time of ordering) - can be turned: 4 positions - internal earth terminal - terminal plate

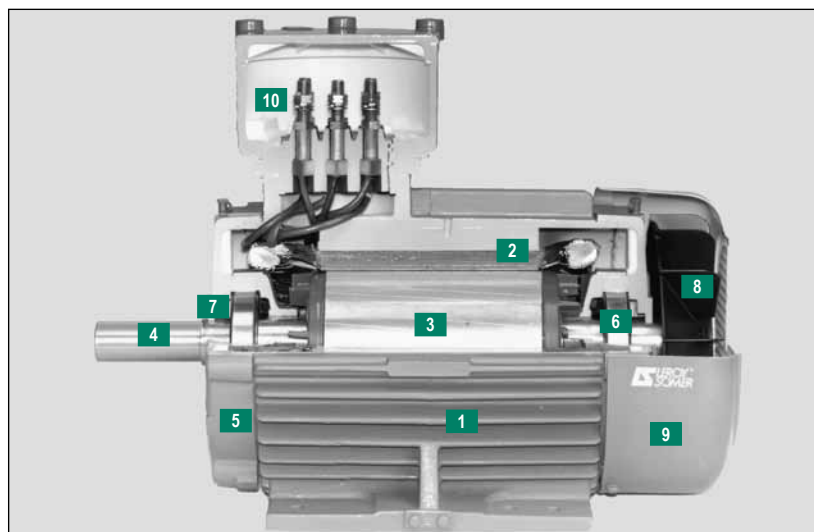

# 3-phase TEFV induction motors ATEX GAS - Zones 1 & 2 Construction



## C2 - Other descriptions of FLSD flameproof motors

### C2.1 - VARIANTS: FLSD CAST IRON MOTORS WITH INCREASED SAFETY TERMINAL BOX Ex d e IIB

These motors have a type "d" flameproof casing and a type "e" increased safety terminal box.

Terminal box	Cast iron	<ul style="list-style-type: none"> <li>- type "e" increased safety</li> <li>- type "d" separation between motor casing and type "e" terminal box</li> <li>- safety terminal block</li> </ul>
--------------	-----------	----------------------------------------------------------------------------------------------------------------------------------------------------------------------------------------------

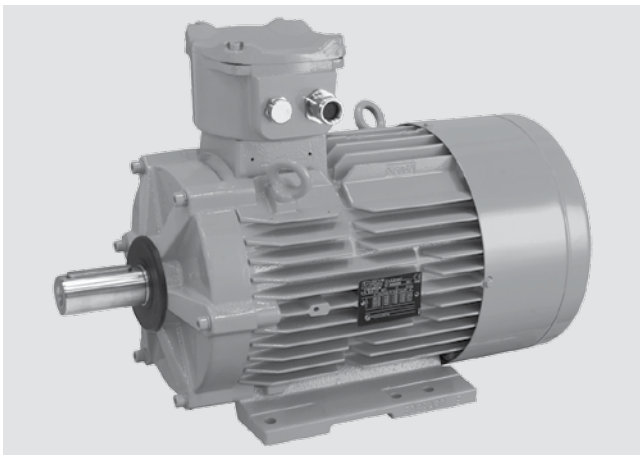

▲ Flameproof motor - Type "d" terminal box

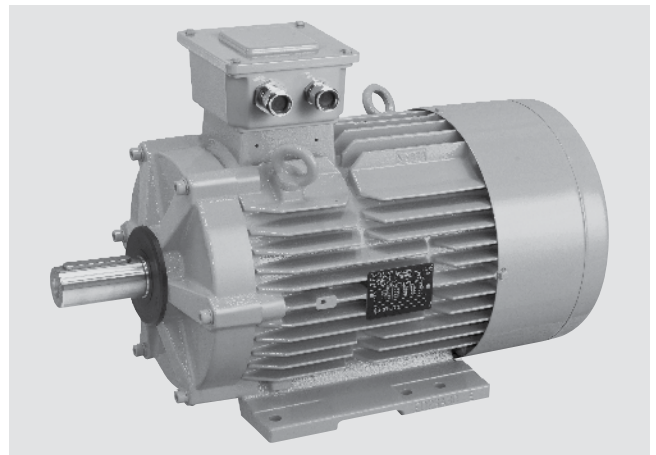

▲ Flameproof motor - Type "e" terminal box

### C2.2 - FLSD CAST IRON MOTORS IN Ex d IIC and Ex d e IIC VERSION (for FRAME SIZE ≤ 250)

These motors are specially machined to comply with the Maximum Experimental Safe Gap (MESG) for group IIC (see sections A4 and A4.5).

# 3-phase TEFV induction motors ATEX GAS - Zones 1 & 2 Construction



## C3 - Description of (F)LSE increased safety motors: Ex "e" and (F)LSN non-sparking motors: Ex "nA"

Component	Materials	Remarks
1 Finned housing	Aluminium alloy or cast iron LSE/LSN FLSE/FLSN	- with integral or screw-on feet, or without feet • 4 or 6 fixing holes for housings with feet • lifting rings for frame size $\geq 132$ M (LSE/LSN) or $\geq 90$ (FLSE/FLSN) - earth terminal
2 Stator	Insulated low-carbon magnetic steel laminations Insulated electroplated copper	- low carbon content guarantees long-term lamination pack stability - welded laminations - semi-enclosed slots - class F insulation
3 Rotor	Insulated low-carbon magnetic steel laminations Aluminium	- inclined cage bars - rotor cage pressure die-cast in aluminium (or alloy for special applications) - shrink-fitted or keyed to shaft - rotor balanced dynamically, class A - 1/2 key
4 Shaft	Steel	- for frame size $\leq 132$ : • shaft end fitted with screw and washer • closed keyway - for frame size $\geq 160$ : • tapped hole • open keyway
5 End shields	Aluminium alloy Cast iron	- LSN-LSE series non drive end frame sizes 80 - 90 - LSN-LSE series frame sizes 80 - 90 drive end (optional for 80 and 90 at non drive end) - LSN-LSE series frame size $\geq 100$ - FLSN-FLSE series all frame sizes
6 Bearings		- bearings preloaded at NDE from 80 to 315 and at DE for FLSN $\geq 315$ M
7 Labyrinth seal Lipseals	Plastic or steel Synthetic rubber	- sealed with gaskets - labyrinth seals, deflector or decompression grooves
8 Fan	Composite material or metal	- 2 directions of rotation: straight blades
9 Fan cover	Pressed steel	- fitted, on request, with a drip cover for operation in vertical position, shaft end facing down
10 Terminal box	Aluminium alloy or cast iron	- IP 55 or IP 65 for "GD" applications - can be turned, opposite the feet - equipped with a block with 6 certified Ex e safety terminals for frame size $\leq 132$ and isolators thereafter - terminal box supplied fitted with certified Ex e safety cable anchor glands - 1 earth terminal in each terminal box (2 from (F)LSN 160 upwards)

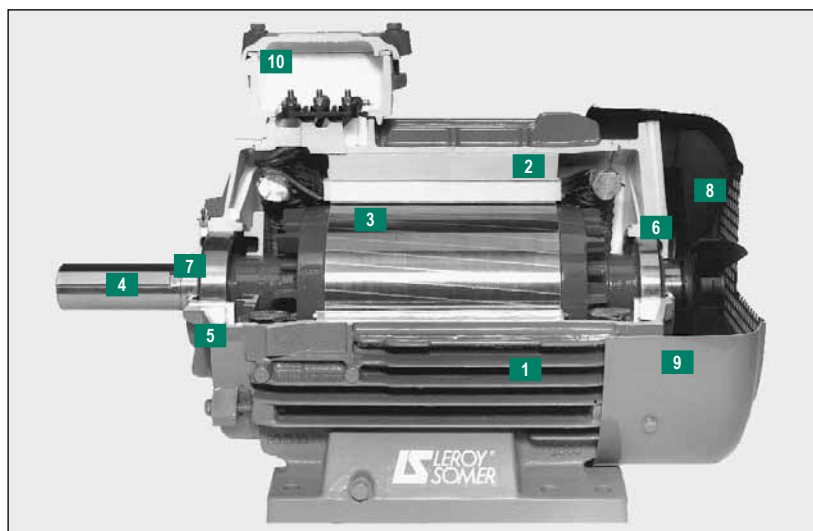

# 3-phase TEFV induction motors ATEX GAS - Zones 1 & 2 Construction



## C4 - Mounting arrangements

Mountings and positions (IEC standard 60034-7)

### Foot mounted motors

**IM 1001** (IM B3)  
- Horizontal shaft  
- Feet on floor

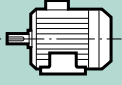

**IM 1071** (IM B8)  
- Horizontal shaft  
- Feet on ceiling

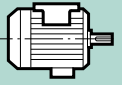

**IM 1051** (IM B6)  
- Horizontal shaft  
- Wall mounted with feet on left when viewed from drive end

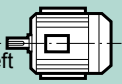

**IM 1011** (IM V5)\*  
- Vertical shaft facing down  
- Feet on wall

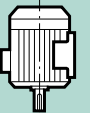

**IM 1061** (IM B7)  
- Horizontal shaft  
- Wall mounted with feet on right when viewed from drive end

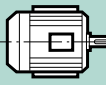

**IM 1031** (IM V6)  
- Vertical shaft facing up  
- Feet on wall

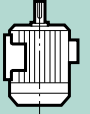

### (FF) flange mounted motors

• All frame sizes  
(except IM 3001, which is limited to frame size 225)

**IM 3001** (IM B5)  
- Horizontal shaft



**IM 2001** (IM B35)  
- Horizontal shaft  
- Feet on floor



**IM 3011** (IM V1)\*  
- Vertical shaft facing down

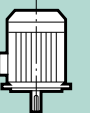

**IM 2011** (IM V15)\*  
- Vertical shaft facing down  
- Feet on wall

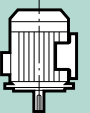

**IM 3031** (IM V3)  
- Vertical shaft facing up

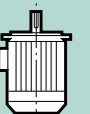

**IM 2031** (IM V36)  
- Vertical shaft facing up  
- Feet on wall

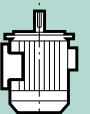

### (FT) face mounted motors

• All frame sizes ≤ 132 mm  
All positions are allowed

**IM 3601** (IM B14)  
- Horizontal shaft



**IM 2101** (IM B34)  
- Horizontal shaft  
- Feet on floor



**IM 3611** (IM V18)\*  
- Vertical shaft facing down

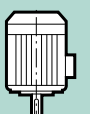

**IM 2111** (IM V58)\*  
- Vertical shaft facing down  
- Feet on wall

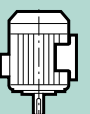

**IM 3631** (IM V19)  
- Vertical shaft facing up

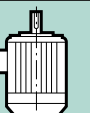

**IM 2131** (IM V69)  
- Vertical shaft facing up  
- Feet on wall



\* All positions with shaft end facing down in an outdoor location require the addition of a drip cover up to frame size 225 (for larger motors, on request).

Frame size	Mounting positions											
	IM 1001	IM 1051	IM 1061	IM 1071	IM 1011	IM 1031	IM 3001	IM 3011	IM 3031	IM 2001	IM 2011	IM 2031
80 to 200	●	●	●	●	●	●	●	●	●	●	●	●
225 and 250	●	●	●	●	●	●	○	●	●	●	●	●
280 and 315	●	○	○	○	○	○	○	●	●	●	●	○
355	●	○	○	○	○	○	□	●	○	●	●	○

● : possible positions    □ : positions not available  
○ : please consult Leroy-Somer specifying the coupling method and the axial and radial loads if applicable

# 3-phase TEFV induction motors ATEX GAS - Zones 1 & 2 Construction



## C5 - Bearings and lubrication

### C5.1 - LUBRICATION OF BEARINGS

▼ Grease life L<sub>10h</sub> in 000's of hours, for frame sizes ≤ 132

#### C5.1.1 - Permanently greased bearings

For motors of frame size ≤ 132 mm, the type and size of the bearings make for long grease life and therefore lubrication for the lifetime of the machine.

The grease life L<sub>10h</sub> according to speed of rotation and ambient temperature is shown on the chart opposite.

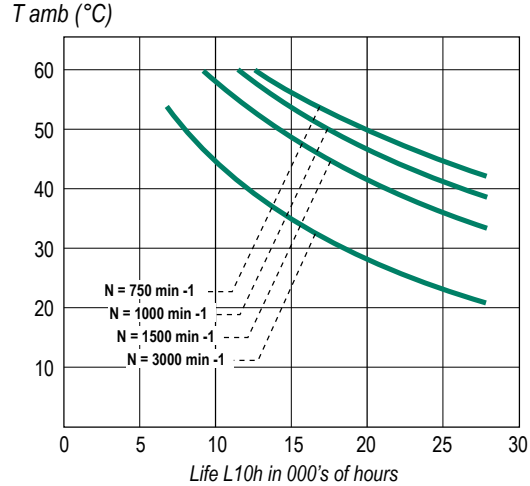

#### C5.1.2 - Bearings without grease nipples only for LSE and LSN

LSE and LSN motors of frame size 160 to 200 are supplied as standard without grease nipples but with permanently greased bearings.

Lubricant lifetime (L<sub>10h</sub>) under normal operating conditions is given in the table below for a machine with horizontal shaft operating at 50 Hz and 60 Hz in ambient temperatures of 25°C or less.

▼ Lubricant lifetime

Frame size \ Speed	3600	3000	1800	1500
160	≥ 40,000	≥ 40,000	≥ 40,000	≥ 40,000
180	≥ 40,000	≥ 40,000	≥ 40,000	≥ 40,000
200	16,000	24,000	32,000	≥ 40,000

**Note:** On request, motors of frame size 90 to 200 mm can be fitted with grease nipples, and motors of frame size 225 and 250 can be supplied without grease nipples.

#### C5.1.3 - Bearings with grease nipples

FLSD and FLSN motors of frame size ≥ 160 mm and also LSE/LSN motors size ≥ 225 mm are fitted with grease nipples. The table in section 5.1.3.1 (on the next page) indicates the type of ball bearing, the quantity of grease and the regreasing intervals according to the type of motor, for an ambient temperature of 25°C.

For vertical shaft machines used in an ambient temperature of 25°C, the regreasing intervals will be approximately 80% of the values stated.

Motors operating in an ambient temperature of 40°C need more frequent lubrication. The regreasing intervals will be around 50% of the values stated (in all cases, comply with the requirements on the motor nameplates).

Grease references: see instructions on nameplate.

The table on the next page is valid for LS motors lubricated with ESSO UNIREX N3 grease, which is used as standard, and also KLUBER BQ72-72 grease for FLSD and FLSN 315 ST/M/L and 355 L, 2-pole versions only.

# 3-phase TEFV induction motors ATEX GAS - Zones 1 & 2 Construction



## C5 - Bearings and lubrication

### C5.1.3.1 - Type of bearing - Quantity of grease - Regreasing intervals for an ambient temperature of 25°C et 40°C

Type	Frame size	No. of poles	Permanently greased bearings		Quantity of grease g	Regreasing intervals in hours							
			N.D.E.	D.E.		3000 rpm		1500 rpm		1000 rpm		750 rpm	
Ex d(e)			Type of bearing for bearings with grease nipples			25°C	40°C	25°C	40°C	25°C	40°C	25°C	40°C
			N.D.E.	D.E.									
	80	2 ; 4 ; 6 ; 8	6204 ZZ C3	6204 ZZ C3									
	90	2 ; 4 ; 6 ; 8	6205 ZZ C3	6205 ZZ C3									
	100	2 ; 4 ; 6 ; 8	6206 ZZ C3	6206 ZZ C3									
	112	2 ; 4 ; 6 ; 8	6206 ZZ C3	6206 ZZ C3									
	132	2 ; 4 ; 6 ; 8	6308 ZZ C3	6308 ZZ C3									
Ex d(e)	160 - 180	2 ; 4 ; 6 ; 8	6310 C3	6310 C3	15	9200	4600	22000	11000	19500	9750	19500	9750
	200	2 ; 4 ; 6 ; 8	6312 C3	6312 C3	19	7200	3600	19400	9700	18000	9000	18000	9000
	225	2 ; 4 ; 6 ; 8	6312 C3	6313 C3	22	6400	3200	18000	9000	16500	8250	16500	8250
	250	2 ; 4 ; 6 ; 8	6314 C3	6314 C3	25	5600	2800	16600	8300	16000	8000	16000	8000
	280	2	6317 C3	6317 C3	36	3400	1700	-	-	-	-	-	-
	280	4 ; 6 ; 8	6318 C3	6318 C3	39	-	-	12400	6200	16000	8000	16000	8000
	315	2	6317 C4	6317 C4	36	3400	1700	-	-	-	-	-	-
	315	4 ; 6 ; 8	6320 C3	6320 C3	49	-	-	10800	5400	16000	8000	16000	8000
	355	2	6317 C4	6317 C4	36	3400	1700	-	-	-	-	-	-
	355	4 ; 6 ; 8	6322 C3	6322 C3	58	-	-	9000	4500	16000	8000	16000	8000

1 cm<sup>3</sup>=0.97 g

Type	Frame size	No. of poles	Permanently greased bearings		Quantity of grease g	Regreasing intervals in hours							
			N.D.E.	D.E.		3000 rpm		1500 rpm		1000 rpm		750 rpm	
Ex e II T3 FLSE & Ex nA II T3 FLSN			Type of bearing for bearings with grease nipples			25°C	40°C	25°C	40°C	25°C	40°C	25°C	40°C
			N.D.E.	D.E.									
	80	2 ; 4 ; 6 ; 8	6203 ZZ C3	6204 ZZ C3									
	90	2 ; 4 ; 6 ; 8	6204 ZZ C3	6205 ZZ C3									
	100	2 ; 4 ; 6 ; 8	6205 ZZ C3	6206 ZZ C3									
	112	2 ; 4 ; 6 ; 8	6205 ZZ C3	6206 ZZ C3									
	132	2 ; 4 ; 6 ; 8	6207 ZZ C3	6308 ZZ C3									
Ex e II T3 FLSE & Ex nA II T3 FLSN	160	2 ; 4 ; 6 ; 8	6210 Z C3	6309 Z C3	13	11600	5800	17000	8500	21000	10500	21000	10500
	180 M	2 ; 4	6210 Z C3	6310 Z C3	15	9400	4700	15500	7750	-	-	-	-
	180 L	4 ; 6 ; 8	6212 Z C3	6310 Z C3	15	-	-	15500	7750	19500	9750	19500	9750
	200 L	2 ; 4 ; 6 ; 8	6313 C3	6313 C3	25	6600	3300	12500	6250	16500	8250	16500	8250
	225 S	4 ; 6 ; 8	6313 C3	6313 C3	25	-	-	12500	6250	16500	8250	16500	8250
	225 MT	2	6313 C3	6313 C3	25	6600	3300	-	-	-	-	-	-
	225 M	4 ; 6 ; 8	6314 C3	6314 C3	25	-	-	12000	6000	16000	8000	16000	8000
	250 M	2 ; 4 ; 6 ; 8	6314 C3	6314 C3	25	6000	3000	12000	6000	16000	8000	16000	8000
	280 S/M	2 ; 4 ; 6 ; 8	6314 C3	6316 C3	32	4000	2000	14400	7200	16000	8000	16000	8000
	315 S	2	6317 C4	6317 C4	36	3400	1700	-	-	-	-	-	-
	315 S	4 ; 6 ; 8	6318 C4	6318 C3	39	-	-	12400	6200	16000	8000	16000	8000
	315 M / L	2	6317 C4	6317 C4	36	3400	1700	-	-	-	-	-	-
	315 M / L	4 ; 6 ; 8	6320 C3	6320 C3	49	-	-	10800	5400	16000	8000	16000	8000
	355 L	2	6317 C4	6317 C4	36	3400	1700	-	-	-	-	-	-
	355 LK	4 ; 6 ; 8	6322 C3	6322 C3	58	-	-	9000	4500	16000	8000	16000	8000

1 cm<sup>3</sup>=0.97 g

Type	Frame size	No. of poles	Permanently greased bearings		Quantity of grease g	Regreasing intervals in hours							
			N.D.E.	D.E.		3000 rpm		1500 rpm		1000 rpm		750 rpm	
Ex e II T3 LSE & Ex nA II T3 LSN			Type of bearing for bearings with grease nipples			25°C	40°C	25°C	40°C	25°C	40°C	25°C	40°C
			N.D.E.	D.E.									
	80 L	2 ; 4 ; 6 ; 8	6203 ZZ CN	6204 ZZ C3									
	90 S - SL - L	2 ; 4 ; 6 ; 8	6204 ZZ C3	6205 ZZ C3									
	100 L	2 ; 4 ; 6 ; 8	6205 ZZ C3	6206 ZZ C3									
	112 M - MR - MG	2 ; 4 ; 6 ; 8	6205 ZZ C3	6206 ZZ C3									
	112 MU	2 ; 4 ; 6 ; 8	6206 ZZ C3	6206 ZZ C3									
	132 S	2 ; 4 ; 6 ; 8	6206 ZZ C3	6208 ZZ C3									
	132 M - SM - MU	2 ; 4 ; 6 ; 8	6207 ZZ C3	6308 ZZ C3									
	160 MP	2 ; 4	6208 ZZ C3	6309 ZZ C3									
	160 M	6 ; 8	6210 ZZ C3	6309 ZZ C3									
	160 LR	4	6308 ZZ C3	6309 ZZ C3									
	160 L	2 ; 4 ; 6 ; 8	6210 ZZ C3	6309 ZZ C3									
	180 MT - LR	2 ; 4	6210 ZZ C3	6310 ZZ C3									
	180 L - LU	4 ; 6 ; 8	6212 Z C3	6310 Z C3									
	200 LT	2 ; 4 ; 6	6212 Z C3	6312 C3									
	200 L	2 ; 6 ; 8	6214 Z C3	6312 C3									
Ex e II T3 LSE & Ex nA II T3 LSN	225 ST - MT	2 ; 4 ; 6 ; 8	6214 Z C3	6313 C3	25	6600	3300	12500	6250	16500	8250	16500	8250
	225 SR - MR	2 ; 4 ; 6 ; 8	6312 C3	6313 C3	25	6600	3300	12500	6250	16500	8250	16500	8250
	250 MZ	2	6312 C3	6313 C3	25	6600	3300	-	-	-	-	-	-
	250 ME	4 ; 6 ; 8	6216 C3	6314 C3	25	-	-	12000	6000	16000	8000	16000	8000
	280 SC - MC	2	6216 C3	6314 C3	25	6000	3000	-	-	-	-	-	-
	280 SC	4 ; 6 ; 8	6216 C3	6316 C3	35	-	-	10500	5250	14500	7250	14500	7250
	280 MD	4 ; 8	6218 C3	6313 C3	25	-	-	10500	5250	14500	7250	14500	7250

# 3-phase TEFV induction motors ATEX GAS - Zones 1 & 2 Construction



## C5 - Bearings and lubrication

### C5.2 - GREASE LIFE

The lifetime of a lubricating grease depends on:

- the characteristics of the grease (type of soap and base oil, etc)
- service stress (type and size of bearing, speed of rotation, operating temperature, etc)
- contamination

### C5.3 - STANDARD BEARING FITTING ARRANGEMENTS

Increased safety/Non-sparking LSE/LSN with aluminium frame		Horizontal shaft	Vertical shaft	
			Shaft facing down	Shaft facing up
	Mounting arrangement	B3 / B6 / B7 / B8	V5	V6
Foot mounted motors	standard mounting	The DE bearing is: - located at DE for frame ≤ 180 - locked for frame ≥ 200	The DE bearing is: - located at DE for frame ≤ 180 - locked for frame ≥ 200	The DE bearing is: - locked for frame ≥ 100
	on request	DE bearing locked	DE bearing locked	
	Mounting arrangement	B5 / B35 / B14 / B34	V1 / V15 / V18 / V58	V3 / V36 / V19 / V69
Flange mounted motors (or foot and flange)	standard mounting	The DE bearing is locked	The DE bearing is locked	The DE bearing is locked

Increased safety/Non-sparking FLSE/FLSN/FLSD with cast iron frame		Horizontal shaft	Vertical shaft	
			Shaft facing down	Shaft facing up
	Mounting arrangement	B3 / B6 / B7 / B8	V5	V6
Foot mounted motors	standard mounting	The DE bearing is: - located at DE for frame ≤ 132 - locked for 160 ≤ frame ≤ 315 S The NDE bearing is locked on frames 315 M to 450.	The DE bearing is: - located at DE for frame ≤ 132 - locked for 160 ≤ frame ≤ 315 S The NDE bearing is locked on frames 315 M to 450.	The DE bearing is: - located at DE for frame ≤ 90 - locked for 100 ≤ frame ≤ 315 S The NDE bearing is locked on frames 315 M to 450.
	on request	DE bearing locked for frame ≤ 132	DE bearing locked for frame ≤ 132	DE bearing locked for frame ≤ 90
	Mounting arrangement	B5 / B35 / B14 / B34	V1 / V15 / V18 / V58	V3 / V36 / V19 / V69
Flange mounted motors (or foot and flange)	standard mounting	The DE bearing is locked for frames 80 to 315 S. The NDE bearing is locked on frames 315 M to 450.	The DE bearing is locked on frames 80 to 315 S. The NDE bearing is locked on frames 315 M to 450.	The DE bearing is locked on frames 80 to 315 S. The NDE bearing is locked on frames 315 M to 450.

# 3-phase TEFV induction motors ATEX GAS - Zones 1 & 2 Construction



## C6 - Axial load of FLSD motors

C6.1 - Permissible axial load (in daN) on main shaft extension for standard bearing assembly in FLSD flameproof motors

Horizontal motor

Nominal bearing lifetime  $L_{10h}$ :  
25,000 hours

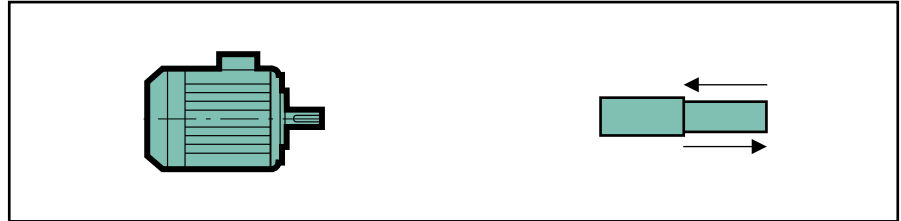

Motor		2 poles N = 3000 min <sup>-1</sup>		4 poles N = 1500 min <sup>-1</sup>		6 poles N = 1000 min <sup>-1</sup>		8 poles N = 750 min <sup>-1</sup>	
Framesize	Type	→	←	→	←	→	←	→	←
		IM B3 / B6 IM B7 / B8 IM B5 / B35 IM B14 / B34	IM B3 / B6 IM B7 / B8 IM B5 / B35 IM B14 / B34	IM B3 / B6 IM B7 / B8 IM B5 / B35 IM B14 / B34	IM B3 / B6 IM B7 / B8 IM B5 / B35 IM B14 / B34	IM B3 / B6 IM B7 / B8 IM B5 / B35 IM B14 / B34	IM B3 / B6 IM B7 / B8 IM B5 / B35 IM B14 / B34	IM B3 / B6 IM B7 / B8 IM B5 / B35 IM B14 / B34	IM B3 / B6 IM B7 / B8 IM B5 / B35 IM B14 / B34
80	FLSD 80 L	21.4	61.4	37.6	77.6	63	63	65	65
90	FLSD 90 S	20.6	(70.6)*	37.3	(87.3)*	82	(110)*	91	(120)*
90	FLSD 90 L	20	(70)*	35.2	(85.2)*	82	(110)*	91	(120)*
100	FLSD 100 L	30.1	(90.1)*	49.6	(109.6)*	103	(138)*	114	(150)*
112	FLSD 112 M	32.1	(92.1)*	32.8	(92.8)*	101	(140)*	112	(150)*
132	FLSD 132 S	93.5	183.5	131.8	221.8	181	230	201	250
132	FLSD 132 M	95	185	136.3	226.3	181	230	201	250
160	FLSD 160 M	160	268	216	324	256	364	286	395
160	FLSD 160 L	160	268	216	324	256	364	286	395
180	FLSD 180 M	160	268	216	324	-	-	-	-
180	FLSD 180 L	-	-	216	324	256	364	286	395
200	FLSD 200 L	230	338	303	411	357	465	396	504
225	FLSD 225 S	-	-	353	461	-	-	458	566
225	FLSD 225 M	269	377	353	461	413	521	458	566
250	FLSD 250 M	334	414	460	540	559	639	638	718
280	FLSD 280 S	358	518	526	686	642	802	713	873
280	FLSD 280 M	505	345	494	654	595	755	685	805
315	FLSD 315 S/M	486	326	746	546	905	705	963	763
315	FLSD 315 LA	504	344	728	528	886	686	940	740
315	FLSD 315 LB	487	327	733	533	847	647	890	690
355	FLSD 355 LA	453	293	788	587	934	694	1006	770
355	FLSD 355 LB	448	288	771	531	892	652	945	705
355	FLSD 355 LC	443	285	751	512	-	-	-	-
355	FLSD 355 LD	440	280	736	496	805	565	871	631

(\* The axial loads in brackets are the permissible axial loads for locked DE bearings (non-standard assembly, special order).

# 3-phase TEFV induction motors ATEX GAS - Zones 1 & 2 Construction



## C6 - Axial load of FLSD motors

C6.2 - Permissible axial load (in daN) on main shaft extension for standard bearing assembly in FLSD flameproof motors

Vertical motor  
Shaft facing down

Nominal bearing lifetime  $L_{10h}$ :  
25,000 hours

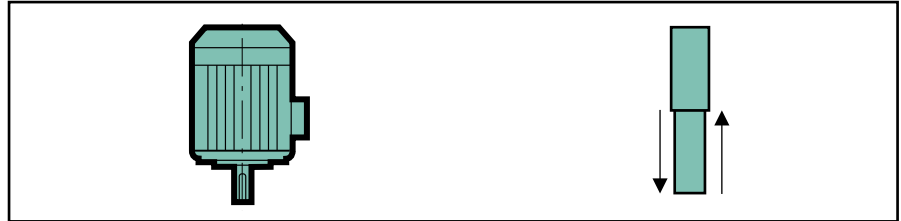

Motor		2 poles N = 3000 min <sup>-1</sup>		4 poles N = 1500 min <sup>-1</sup>		6 poles N = 1000 min <sup>-1</sup>		8 poles N = 750 min <sup>-1</sup>	
Framesize	Type	↓	↑	↓	↑	↓	↑	↓	↑
		IM V5 IM V1 / V15 IM V18 / V58..	IM V5 IM V1 / V15 IM V18 / V69..	IM V5 IM V1 / V15 IM V18 / V69..	IM V5 IM V1 / V15 IM V18 / V69..	IM V5 IM V1 / V15 IM V18 / V69..	IM V5 IM V1 / V15 IM V18 / V69..	IM V5 IM V1 / V15 IM V18 / V69..	IM V5 IM V1 / V15 IM V18 / V69..
80	FLSD 80 L	19.8	64.1	35.1	81.7	59	68	60	69
90	FLSD 90 S	18	(74.9)*	34.7	(92)*	76	(117)*	85	(126)*
90	FLSD 90 L	17.3	(74.8)*	32.1	(90.5)*	75	(117)*	84	(126)*
100	FLSD 100 L	26.7	(95.9)*	44.5	(118.3)*	95	(146)*	106	(157)*
112	FLSD 112 M	26.9	(100.9)*	25.2	(105)*	89	(152)*	100	(163)*
132	FLSD 132 S	84.9	199.3	119.2	242.8	156	255	184	267
132	FLSD 132 M	84.1	202.7	122.5	248.7	156	255	180	271
160	FLSD 160 M	133	295	184	355	222	400	251	428
160	FLSD 160 L	128	300	177	363	214	406	247	433
180	FLSD 180 M	121	307	171	368	-	-	-	-
180	FLSD 180 L	-	-	166	373	203	417	236	443
200	FLSD 200 L	168	400	238	477	281	540	311	590
225	FLSD 225 S	-	-	275	538	-	-	369	655
225	FLSD 225 M	195	450	265	548	319	615	357	667
250	FLSD 250 M	268	481	376	627	460	740	538	620
280	FLSD 280 S	424	493	552	727	676	831	726	941
280	FLSD 280 M	400	500	504	734	616	824	639	926
315	FLSD 315 S/M	361	545	582	861	764	976	800	1084
315	FLSD 315 LA	344	572	546	876	726	988	756	1090
315	FLSD 315 LB	306	596	514	909	644	1018	680	1100
355	FLSD 355 LA	244	648	512	1050	684	1175	720	1340
355	FLSD 355 LB	222	667	475	1067	605	1199	618	1367
355	FLSD 355 LC	195	692	425	1081	-	-	-	-
355	FLSD 355 LD	175	707	391	1107	432	1259	494	1397

(\*) The axial loads in brackets are the permissible axial loads for locked DE bearings (non-standard assembly, special order).

# 3-phase TEFV induction motors ATEX GAS - Zones 1 & 2 Construction



## C6 - Axial load of FLSD motors

**C6.3 - Permissible axial load (in daN) on main shaft extension for standard bearing assembly in FLSD flameproof motors**

Vertical motor  
Shaft facing up

Nominal bearing lifetime  $L_{10h}$ :  
25,000 hours

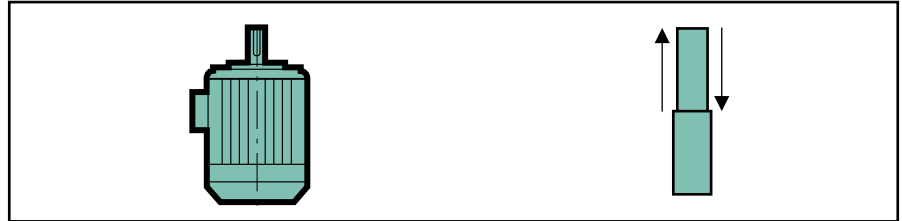

Motor		2 poles N = 3000 min <sup>-1</sup>		4 poles N = 1500 min <sup>-1</sup>		6 poles N = 1000 min <sup>-1</sup>		8 poles N = 750 min <sup>-1</sup>	
Framesize	Type	↓	↑	↓	↑	↓	↑	↓	↑
		IM V6 IM V3 / V36 IM V19 / V69..	IM V6 IM V3 / V36 IM V19 / V69..	IM V6 IM V3 / V36 IM V19 / V69..	IM V6 IM V3 / V36 IM V19 / V69..	IM V6 IM V3 / V36 IM V19 / V69..	IM V6 IM V3 / V36 IM V19 / V69..	IM V6 IM V3 / V36 IM V19 / V69..	IM V6 IM V3 / V36 IM V19 / V69..
80	FLSD 80 L	24.1	59.8	35.1	81.7	59	68	60	69
90	FLSD 90 S	(24.9)*	68	(42)*	84.7	(105)*	87	(115)*	97
90	FLSD 90 L	(24.8)*	67.3	(40.5)*	82.1	(105)*	88	(114)*	97
100	FLSD 100 L	(35.9)*	86.7	(58.3)*	104.5	(130)*	110	(142)*	122
112	FLSD 112 M	(40.9)*	86.9	(45)*	85.2	(128)*	112	(140)*	123
132	FLSD 132 S	107.3	175.5	152.8	209.2	205	206	233	218
132	FLSD 132 M	114.2	175.6	158.7	212.5	205	206	230	222
160	FLSD 160 M	240	187	292	247	330	290	360	320
160	FLSD 160 L	236	192	285	255	322	300	355	325
180	FLSD 180 M	229	200	280	260	-	-	-	-
180	FLSD 180 L	-	-	275	265	310	310	344	335
200	FLSD 200 L	277	286	346	370	390	432	420	481
225	FLSD 225 S	-	-	383	430	-	-	477	547
225	FLSD 225 M	303	343	373	440	427	507	466	560
250	FLSD 250 M	348	400	456	547	540	660	618	740
280	FLSD 280 S	424	493	552	727	676	831	726	941
280	FLSD 280 M	401	502	504	735	616	824	639	926
315	FLSD 315 S/M	361	545	582	861	764	976	800	1084
315	FLSD 315 LA	344	572	546	876	726	988	756	1091
315	FLSD 315 LB	306	596	514	909	644	1018	681	1098

355: prior consultation

(\*) The axial loads in brackets are the permissible axial loads for locked DE bearings (non-standard assembly, special order).

# 3-phase TEFV induction motors ATEX GAS - Zones 1 & 2 Construction



## C7 - Axial load of LSE/LSN motors

C7.1 - Permissible axial load (in daN) on main shaft extension for standard bearing assembly in LSE/LSN increased safety and non-sparking motors with aluminium frame

Horizontal motor

Nominal bearing lifetime  $L_{10h}$ :  
25,000 hours

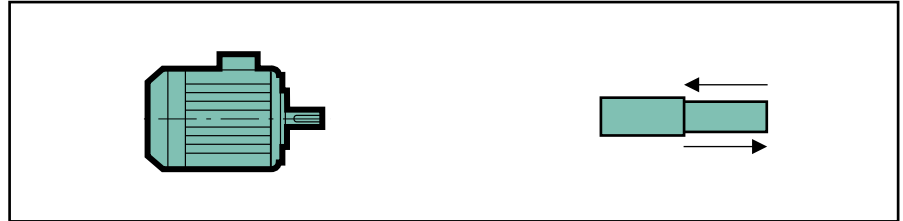

Motor		2 poles N = 3000 min <sup>-1</sup>		4 poles N = 1500 min <sup>-1</sup>		6 poles N = 1000 min <sup>-1</sup>		8 poles N = 750 min <sup>-1</sup>	
Framesize	Type	→	←	→	←	→	←	→	←
		IM B3 / B6 IM B7 / B8 IM B5 / B35 IM B14 / B34	IM B3 / B6 IM B7 / B8 IM B5 / B35 IM B14 / B34	IM B3 / B6 IM B7 / B8 IM B5 / B35 IM B14 / B34	IM B3 / B6 IM B7 / B8 IM B5 / B35 IM B14 / B34	IM B3 / B6 IM B7 / B8 IM B5 / B35 IM B14 / B34	IM B3 / B6 IM B7 / B8 IM B5 / B35 IM B14 / B34	IM B3 / B6 IM B7 / B8 IM B5 / B35 IM B14 / B34	IM B3 / B6 IM B7 / B8 IM B5 / B35 IM B14 / B34
80	LSE/LSN 80 L	23	(61)*	37	(75)*	45	(83)*	55	(93)*
90	LSE/LSN 90 SR	19	(69)*	35	(85)*	44	(94)*	55	(105)*
90	LSE/LSN 90 S	19	(69)*	35	(85)*	44	(94)*	55	(105)*
90	LSE/LSN 90 L	19	(69)*	35	(85)*	44	(94)*	55	(105)*
100	LSE/LSN 100 L	34	(90)*	57	(113)*	68	(124)*	83	(139)*
112	LSE/LSN 112 M*	32	(88)*	46	(102)*	63	(119)*	78	(134)*
132	LSE/LSN 132 S	59	(137)*	92	(170)*	114	(192)*	-	-
132	LSE/LSN 132 M	86	(188)*	125	(227)*	159	(261)*	192	(294)*
160	LSE/LSN 160 M	-	-	-	-	237	(337)*	268	(368)*
160	LSE/LSN 160 MP	147	(227)*	197	(277)*	-	-	-	-
160	LSE/LSN 160 LR	-	-	188	(278)*	-	-	-	-
160	LSE/LSN 160 L	131	(231)*	-	-	219	(319)*	249	(349)*
180	LSE/LSN 180 MT	159	(259)*	207	(307)*	-	-	-	-
180	LSE/LSN 180 LR	-	-	193	(293)*	-	-	-	-
180	LSE/LSN 180 L	-	-	-	-	270	(318)*	318	(366)*
200	LSE/LSN 200 LT	255	303	312	360	372	420	-	-
200	LSE/LSN 200 L	247	313	-	-	366	432	455	521
225	LSE/LSN 225 ST	-	-	366	432	-	-	501	567
225	LSE/LSN 225 MT	278	344	-	-	-	-	-	-
225	LSE/LSN 225 MR	-	-	350	413	370	433	477	540
250	LSE/LSN 250 MZ	275	338	-	-	-	-	-	-
250	LSE/LSN 250 ME	-	-	392	462	451	521	523	593
280	LSE/LSN 280 SC	294	364	464	534	538	608	627	697
280	LSE/LSN 280 MC	291	361	-	-	524	594	-	-
280	LSE/LSN 280 MD	-	-	437	507	-	-	569	657

(\*) The axial loads shown above for IM B3/B6/B7/B8 forms with frame size ≤ 180 are the permissible axial loads for locked DE bearings (non-standard assembly, special order).

\* Also applies to 112 MG and MU.

# 3-phase TEFV induction motors ATEX GAS - Zones 1 & 2 Construction



## C7 - Axial load of LSE/LSN motors

C7.2 - Permissible axial load (in daN) on main shaft extension for standard bearing assembly in LSE/LSN increased safety and non-sparking motors with aluminium frame

Vertical motor  
Shaft facing down

Nominal bearing lifetime  $L_{10h}$ :  
25,000 hours

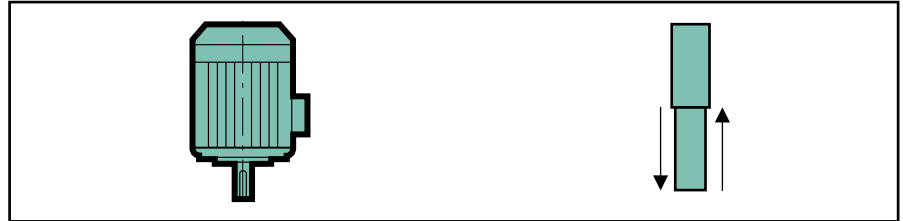

Motor		2 poles N = 3000 min <sup>-1</sup>		4 poles N = 1500 min <sup>-1</sup>		6 poles N = 1000 min <sup>-1</sup>		8 poles N = 750 min <sup>-1</sup>	
Framesize	Type	↓	↑	↓	↑	↓	↑	↓	↑
		IM V5 IM V1 / V15 IM V18 / V58..	IM V5 IM V1 / V15 IM V18 / V69..	IM V5 IM V1 / V15 IM V18 / V69..	IM V5 IM V1 / V15 IM V18 / V69..	IM V5 IM V1 / V15 IM V18 / V69..	IM V5 IM V1 / V15 IM V18 / V69..	IM V5 IM V1 / V15 IM V18 / V69..	IM V5 IM V1 / V15 IM V18 / V69..
80	LSE/LSN 80 L	22	(63)*	35	(79)*	42	(89)*	52	(99)*
90	LSE/LSN 90 SR	17	(73)*	31	(91)*	41	(100)*	52	(111)*
90	LSE/LSN 90 S	17	(73)*	31	(91)*	41	(100)*	52	(111)*
90	LSE/LSN 90 L	17	(73)*	31	(91)*	41	(100)*	52	(111)*
100	LSE/LSN 100 L	32	(94)*	54	(119)*	64	(131)*	79	(146)*
112	LSE/LSN 112 M*	29	(93)*	41	(111)*	57	(129)*	72	(144)*
132	LSE/LSN 132 S	51	(149)*	83	(185)*	105	(207)*	-	-
132	LSE/LSN 132 M	73	(207)*	110	(251)*	140	(291)*	176	(321)*
160	LSE/LSN 160 M	-	-	-	-	213	(376)*	245	(408)*
160	LSE/LSN 160 MP	129	(245)*	177	(297)*	-	-	-	-
160	LSE/LSN 160 LR	-	-	165	(301)*	-	-	-	-
160	LSE/LSN 160 L	111	(261)*	-	-	191	(370)*	224	(397)*
180	LSE/LSN 180 MT	136	(293)*	182	(353)*	-	-	-	-
180	LSE/LSN 180 LR	-	-	166	(345)*	-	-	-	-
180	LSE/LSN 180 L	-	-	-	-	232	(385)*	279	(438)*
200	LSE/LSN 200 LT	222	352	276	429	329	504	-	-
200	LSE/LSN 200 L	209	370	-	-	314	521	403	606
225	LSE/LSN 225 ST	-	-	314	517	-	-	443	670
225	LSE/LSN 225 MT	236	408	-	-	-	-	-	-
225	LSE/LSN 225 MR	-	-	292	514	310	553	414	661
250	LSE/LSN 250 MZ	225	414	-	-	-	-	-	-
250	LSE/LSN 250 ME	-	-	311	607	363	687	424	778
280	LSE/LSN 280 SC	224	481	360	707	436	795	511	904
280	LSE/LSN 280 MC	209	492	-	-	406	804	-	-
280	LSE/LSN 280 MD	-	-	315	718	-	-	439	908

(\*) The axial loads shown above for IM V5 form with frame size ≤ 180 are the permissible axial loads for locked DE bearings (non-standard assembly, special order).

\* Also applies to 112 MG and MU.

# 3-phase TEFV induction motors ATEX GAS - Zones 1 & 2 Construction



## C7 - Axial load of LSE/LSN motors

**C7.3 - Permissible axial load (in daN) on main shaft extension for standard bearing assembly in LSE/LSN increased safety and non-sparking motors with aluminium frame**

Vertical motor  
Shaft facing up

Nominal bearing lifetime  $L_{10h}$ :  
25,000 hours

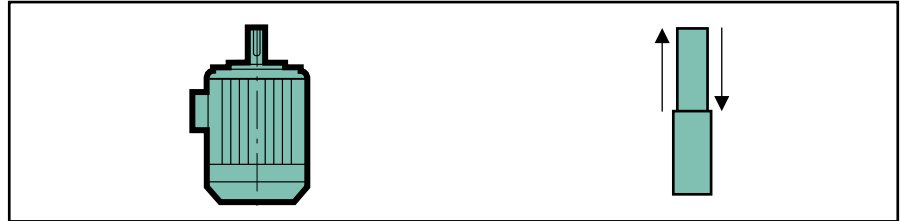

Motor		2 poles N = 3000 min <sup>-1</sup>		4 poles N = 1500 min <sup>-1</sup>		6 poles N = 1000 min <sup>-1</sup>		8 poles N = 750 min <sup>-1</sup>	
Framesize	Type	↓	↑	↓	↑	↓	↑	↓	↑
		IM V6 IM V3 / V36 IM V19 / V69..	IM V6 IM V3 / V36 IM V19 / V69..	IM V6 IM V3 / V36 IM V19 / V69..	IM V6 IM V3 / V36 IM V19 / V69..	IM V6 IM V3 / V36 IM V19 / V69..	IM V6 IM V3 / V36 IM V19 / V69..	IM V6 IM V3 / V36 IM V19 / V69..	IM V6 IM V3 / V36 IM V19 / V69..
80	LSE/LSN 80 L	60	25	73	41	80	51	90	61
90	LSE/LSN 90 SR	67	23	81	41	91	50	102	61
90	LSE/LSN 90 S	67	23	81	41	91	50	102	61
90	LSE/LSN 90 L	67	23	81	41	91	50	102	61
100	LSE/LSN 100 L	88	38	110	63	120	75	135	90
112	LSE/LSN 112 M*	85	37	97	55	113	73	128	88
132	LSE/LSN 132 S	129	71	161	107	183	129	-	-
132	LSE/LSN 132 M	175	105	212	149	242	189	278	219
160	LSE/LSN 160 M	-	-	-	-	313	276	345	308
160	LSE/LSN 160 MP	209	165	257	217	-	-	-	-
160	LSE/LSN 160 LR	-	-	(255)*	211	-	-	-	-
160	LSE/LSN 160 L	211	161	-	-	291	270	324	297
180	LSE/LSN 180 MT	236	193	282	253	-	-	-	-
180	LSE/LSN 180 LR	-	-	266	245	-	-	-	-
180	LSE/LSN 180 L	-	-	-	-	280	337	327	390
200	LSE/LSN 200 LT	270	304	324	381	377	456	-	-
200	LSE/LSN 200 L	275	304	-	-	380	455	469	540
225	LSE/LSN 225 ST	-	-	380	451	-	-	509	604
225	LSE/LSN 225 MT	302	342	-	-	-	-	-	-
225	LSE/LSN 225 MR	-	-	355	451	373	490	477	598
250	LSE/LSN 250 MZ	288	351	-	-	-	-	-	-
250	LSE/LSN 250 ME	-	-	381	537	433	617	494	708
280	LSE/LSN 280 SC	294	411	430	637	506	725	834	581
280	LSE/LSN 280 MC	279	422	-	-	476	734	-	-
280	LSE/LSN 280 MD	-	-	385	648	-	-	820	527

(\*) The axial loads shown above for IM V6 form with frame size ≤ 180 are the permissible axial loads for locked DE bearings (non-standard assembly, special order).

\*Also applies to 112 MG and MU.

# 3-phase TEFV induction motors ATEX GAS - Zones 1 & 2 Construction



## C8 - Axial load of FLSE/FLSN motors

C8.1 - Permissible axial load (in daN) on main shaft extension for standard bearing assembly in FLSE/FLSN increased safety and non-sparking motors with cast iron frame

Horizontal motor

Nominal bearing lifetime  $L_{10h}$ :  
25,000 hours

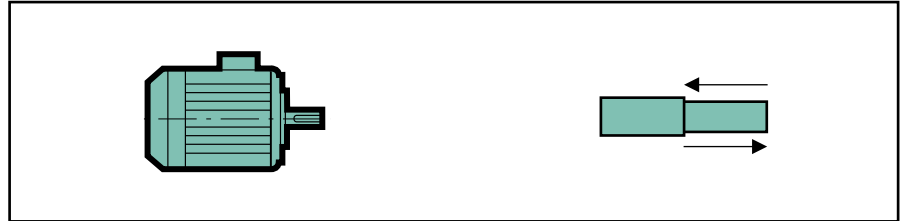

Motor		2 poles N = 3000 min <sup>-1</sup>		4 poles N = 1500 min <sup>-1</sup>		6 poles N = 1000 min <sup>-1</sup>		8 poles N = 750 min <sup>-1</sup>	
		→	←	→	←	→	←	→	←
Framesize	Type	IM B3 / B6 IM B7 / B8 IM B5 / B35 IM B14 / B34		IM B3 / B6 IM B7 / B8 IM B5 / B35 IM B14 / B34		IM B3 / B6 IM B7 / B8 IM B5 / B35 IM B14 / B34		IM B3 / B6 IM B7 / B8 IM B5 / B35 IM B14 / B34	
		80	FLSE/FLSN 80	23	(61)*	37	(75)*	45	(83)*
90	FLSE/FLSN 90 S/L	19	(69)*	35	(85)*	44	(94)*	55	(105)*
100	FLSE/FLSN 100 LK	32	(88)*	46	(102)*	63	(119)*	78	(134)*
112	FLSE/FLSN 112 M	32	(88)*	46	(102)*	63	(119)*	78	(134)*
132	FLSE/FLSN 132 S/M	86	(188)*	125	(227)*	159	(261)*	192	(294)*
160	FLSN 160 M/MA/MB	163	195	224	256	272	304	299	331
160	FLSN 160 L	154	186	210	242	253	285	282	314
180	FLSN 180 MR	188	220	240	272	-	-	-	-
180	FLSN 180 L	-	-	241	287	276	322	313	359
200	FLSN 200 L/LA/LB	270	342	370	442	424	496	483	555
225	FLSN 225 ST/MT	261	333	355	427	-	-	456	528
225	FLSN 225 M	-	-	400	480	468	548	533	613
250	FLSN 250 M	296	376	400	480	468	548	533	613
280	FLSN 280 S	343	423	461	541	532	612	579	659
280	FLSN 280 M	325	405	423	503	455	535	526	606
315	FLSN 315 ST	492	332	461	621	546	706	570	730
315	FLSN 315 M	486	326	746	546	905	705	963	763
315	FLSN 315 LA	504	344	728	528	886	686	938	738
315	FLSN 315 LB	487	327	733	533	847	647	890	690
355	FLSN 355 LA	453	293	788	587	934	694	1006	766
355	FLSN 355 LB	448	288	771	531	892	652	945	705
355	FLSN 355 LC	443	285	751	512	-	-	-	-
355	FLSN 355 LD	440	280	736	496	805	565	871	631

(\* The axial loads shown above for IM B3/B6/B7/B8 forms with frame size ≤ 132 are the permissible axial loads for locked DE bearings (non-standard assembly, special order).

# 3-phase TEFV induction motors ATEX GAS - Zones 1 & 2 Construction



## C8 - Axial load of FLSE/FLSN motors

C8.2 - Permissible axial load (in daN) on main shaft extension for standard bearing assembly in FLSE/FLSN increased safety and non-sparking motors with cast iron frame

Vertical motor  
Shaft facing down

Nominal bearing lifetime  $L_{10h}$ :  
25,000 hours

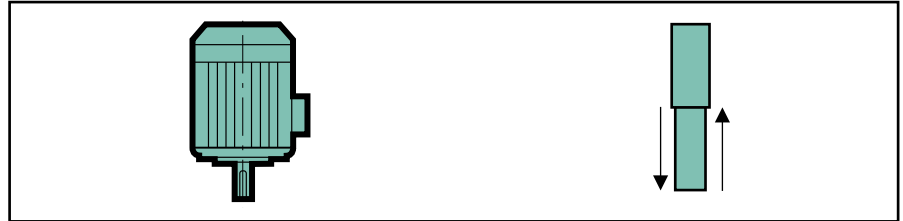

Motor		2 poles N = 3000 min <sup>-1</sup>		4 poles N = 1500 min <sup>-1</sup>		6 poles N = 1000 min <sup>-1</sup>		8 poles N = 750 min <sup>-1</sup>	
Framesize	Type	↓	↑	↓	↑	↓	↑	↓	↑
		IM V5 IM V1 / V15 IM V18 / V69..	IM V5 IM V1 / V15 IM V18 / V69..	IM V5 IM V1 / V15 IM V18 / V69..	IM V5 IM V1 / V15 IM V18 / V69..	IM V5 IM V1 / V15 IM V18 / V69..	IM V5 IM V1 / V15 IM V18 / V69..	IM V5 IM V1 / V15 IM V18 / V69..	IM V5 IM V1 / V15 IM V18 / V69..
80	FLSE/FLSN 80 L	22	(63)*	35	(79)*	42	(89)*	52	(99)*
90	FLSE/FLSN 90 S/L	17	(73)*	31	(91)*	41	(100)*	52	(111)*
100	FLSE/FLSN 100 LK	29	(93)*	41	(111)*	57	(129)*	72	(144)*
112	FLSE/FLSN 112 M	29	(93)*	41	(111)*	57	(129)*	72	(144)*
132	FLSE/FLSN 132 S/M	73	(207)*	110	(251)*	140	(291)*	176	(321)*
160	FLSN 160 M/MA/MB	145	223	204	287	249	339	278	369
160	FLSN 160 L	134	220	187	281	226	332	259	359
180	FLSN 180 MR	164	257	214	320	-	-	-	-
180	FLSN 180 L	-	-	208	342	240	384	276	426
200	FLSN 200 L/LA/LB	230	402	324	517	374	581	432	646
225	FLSN 225 ST/MT	218	402	303	515	-	-	401	634
225	FLSN 225 M	-	-	324	600	382	689	449	753
250	FLSN 250 M	238	465	324	600	382	689	449	753
280	FLSN 280 S	265	545	362	699	491	790	463	869
280	FLSN 280 M	281	507	307	701	347	761	389	869
315	FLSN 315 ST	380	509	457	737	554	814	551	903
315	FLSN 315 M	361	545	582	861	764	976	800	1084
315	FLSN 315 LA	344	572	546	876	726	988	756	1091
315	FLSN 315 LB	306	596	514	909	644	1018	681	1098
355	FLSN 355 LA	244	648	512	1050	684	1175	721	1341
355	FLSN 355 LB	222	667	475	1067	605	1199	618	1367
355	FLSN 355 LC	195	692	425	1081	-	-	-	-
355	FLSN 355 LD	175	707	391	1107	432	1259	494	1397

(\*) The axial loads shown above for IM V6 forms with frame size ≤ 132 are the permissible axial loads for locked DE bearings (non-standard assembly, special order).

# 3-phase TEFV induction motors ATEX GAS - Zones 1 & 2 Construction



## C8 - Axial load of FLSE/FLSN motors

C8.3 - Permissible axial load (in daN) on main shaft extension for standard bearing assembly in FLSE/FLSN increased safety and non-sparking motors with cast iron frame

Vertical motor  
Shaft facing up

Nominal bearing lifetime  $L_{10h}$ :  
25,000 hours

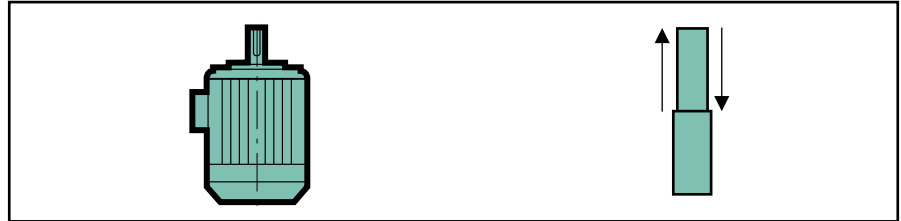

Motor		2 poles N = 3000 min <sup>-1</sup>		4 poles N = 1500 min <sup>-1</sup>		6 poles N = 1000 min <sup>-1</sup>		8 poles N = 750 min <sup>-1</sup>	
Framesize	Type	↓	↑	↓	↑	↓	↑	↓	↑
		IM V6 IM V3 / V36 IM V19 / V69..	IM V6 IM V3 / V36 IM V19 / V69..	IM V6 IM V3 / V36 IM V19 / V69..	IM V6 IM V3 / V36 IM V19 / V69..	IM V6 IM V3 / V36 IM V19 / V69..	IM V6 IM V3 / V36 IM V19 / V69..	IM V6 IM V3 / V36 IM V19 / V69..	IM V6 IM V3 / V36 IM V19 / V69..
80	FLSE/FLSN 80 L	(60)*	25	(73)*	41	(80)*	51	(90)*	51
90	FLSE/FLSN 90 S/L	(67)*	23	(81)*	41	(91)*	50	(102)*	61
100	FLSE/FLSN 100 LK	85	37	97	55	113	73	128	88
112	FLSE/FLSN 112 M	85	37	97	55	113	73	128	88
132	FLSE/FLSN 132 S/M	175	105	212	149	242	189	278	219
160	FLSN 160 M/MA/MB	177	191	236	255	281	307	310	337
160	FLSN 160 L	166	188	219	249	258	300	291	327
180	FLSN 180 MR	196	225	246	288	-	-	-	-
180	FLSN 180 L	-	-	254	296	286	338	322	380
200	FLSN 200 L/LA/LB	302	330	396	445	446	509	504	574
225	FLSN 225 ST/MT	290	330	375	443	-	-	493	562
225	FLSN 225 M	-	-	404	520	462	609	529	673
250	FLSN 250 M	318	385	404	520	462	609	529	673
280	FLSN 280 S	345	465	442	619	511	710	543	789
280	FLSN 280 M	321	467	387	621	427	681	469	789
315	FLSN 315 ST	380	509	457	737	554	814	551	903
315	FLSN 315 M	361	545	582	861	764	976	800	1084
315	FLSN 315 LA	344	572	546	876	726	988	756	1091
315	FLSN 315 LB	306	596	514	909	644	1018	681	1098

355 to 450: prior consultation

(\*) The axial loads shown above for IM V6 forms with frame size ≤ 90 are the permissible axial loads for locked DE bearings (non-standard assembly, special order).

# 3-phase TEFV induction motors ATEX GAS - Zones 1 & 2 Construction



## C9 - Mains connection

### C9.1 - TERMINAL BOX AND CABLE GLAND POSITIONS

Placed as standard on the top of the motor, the terminal box has IP 55 protection and is fitted with a cable gland C9.3 and C9.4. The standard position of the cable gland is on the right, seen from the drive end (position A1) but, owing to the symmetrical construction of the box, it can usually be placed in any of the 4 directions (see table below).

▼ Positions of the terminal box in relation to the drive end (motor in IM 1001 position)

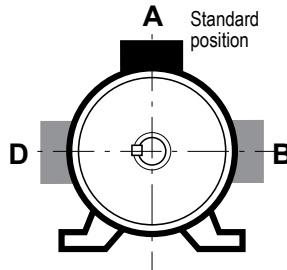

▼ Positions of the cable gland in relation to the motor drive shaft

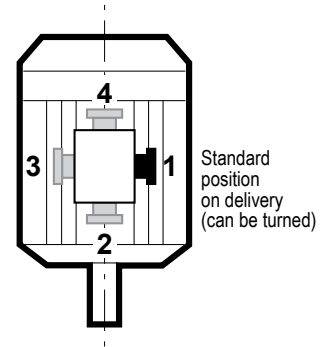

### Type of terminal box used on ATEX motors

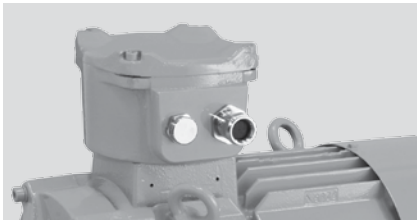

▲ Type "d" terminal box for FLSD frame size 80 to 355 mm

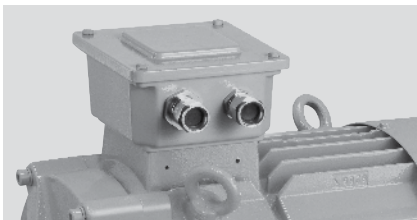

▲ Type "e" terminal box for FLSD/FLSE/FLSN frame size 80 to 132 mm

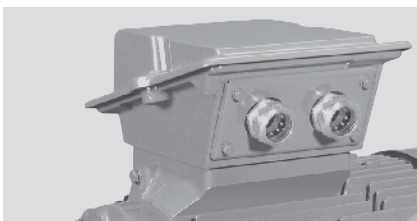

▲ Type "e" terminal box for LSE\*/LSN\*FLSN frame size 160 to 355 mm

\* except 160 MP and 160 LR

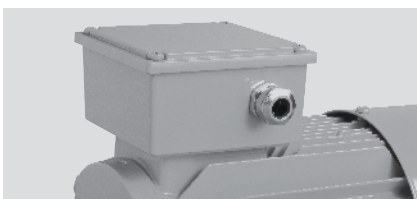

▲ Type "e" terminal box for LSE\*/LSN\* frame size 80 to 160 mm

\* except 160 M and 160 L

Terminal box position	A	B	D
LSN - LSE	●	●	●
FLSE	●	-	-
FLSN 80 to 225 MT	●	-	-
FLSN 225 M to 355	●	●*	●*
FLSD 80 to 280	●	-	-
FLSD 315 to 355	●	○	○

\* except the FLSN 315 ST

● standard    ● fixed-price option    ○ please consult Leroy-Somer    - not possible

Cable gland position	1	2*	3	4
(F)LSN - (F)LSE	●	●	●	●
FLSD	●	-	●	●

\* not recommended (impossible on (FF) flange mounted motors and on the FLSN 355 LK)

● standard    ● possible by simply turning round the terminal box<sup>1</sup>    - not possible

<sup>1</sup> **Important:** Take the necessary precautions when dismantling and re-assembling the terminal box, in order to maintain safety of the equipment. This is the responsibility of the person carrying out the operation.

# 3-phase TEFV induction motors ATEX GAS - Zones 1 & 2 Construction



## C9 - Mains connection

### C9.2 - POWER SUPPLY CABLES (diameters to be supplied for selection of the cable gland)

**Non-armoured cable**  
(used in conjunction with cable gland type 1F)

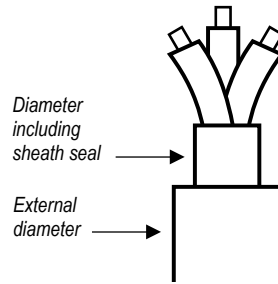
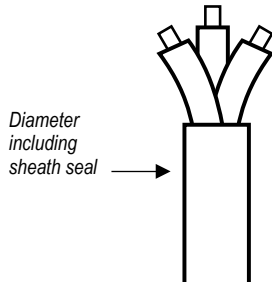

**Armoured cable**  
(used in conjunction with cable gland type 4F)

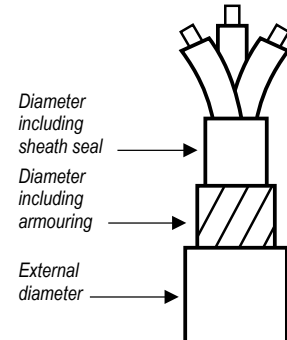

The sheath seal diameter of the power supply cable is compressed by an approved cable gland ring, thus creating the flameproof seal. Anchoring generally affects the external diameter of the cable.

The sheath seal diameter must correspond to a permissible diameter for the cable gland.  
THIS CONDITION IS ESSENTIAL FOR MAINTAINING THE FLAMEPROOF PROPERTIES OF THE MOTOR.

### C9.3 - NUMBER AND TYPE OF ADAPTABLE CABLE GLANDS ON TYPE "d" terminal box FOR FLSD FLAMEPROOF MOTORS

The following table indicates for standard terminal boxes:

- the cable gland normally supplied
- the largest size of cable gland which can be supplied for connecting a single cable
- the largest size of cable gland which can be supplied for connecting two cables

Terminal box for frame size	Standard cable gland		Largest size for 1 cable gland		Largest size for 2 cable glands	
	Type	Permissible cable Ø (mm)	Type	Permissible cable Ø (mm)	Type	Permissible cable Ø (mm)
FLSD 80 - 90 - 100	ISO M20 x 1.5	8.5 to 16	ISO M25 x 1.5	12 to 20.5	ISO M25 x 1.5	12 to 20.5
FLSD 112 - 132	ISO M25 x 1.5	8.5 to 16	ISO M25 x 1.5	12 to 20.5	ISO M25 x 1.5	12 to 20.5
FLSD 160 - 180	ISO M32 x 1.5	16 to 27.5	ISO M50 x 1.5	27 to 41	ISO M50 x 1.5	27 to 41
FLSD 200 - 225	ISO M40 x 1.5	21 to 34	ISO M50 x 1.5	27 to 41	ISO M50 x 1.5	27 to 41
FLSD 250	ISO M40 x 1.5	21 to 34	ISO M75 x 1.5	47 to 65	ISO M75 x 1.5	47 to 65
FLSD 280	ISO M50 x 1.5	27 to 41	ISO M75 x 1.5	47 to 65	ISO M75 x 1.5	47 to 65
FLSD 315 S/M	ISO M63 x 1.5	33 to 48	ISO M75 x 1.5	47 to 65	ISO M75 x 1.5	47 to 65
FLSD 315 L	ISO M75 x 1.5	47 to 65	ISO M75 x 1.5	47 to 65	ISO M75 x 1.5	47 to 65
FLSD 355	2 x M63 x 1.5	33 to 48	ISO M75 x 1.5	47 to 65	ISO M75 x 1.5	47 to 65

Cable gland for accessories (PTC, Pt100, heating resistors): ISO M20 x 1.5 for sheath seal cable diameter between 8.5 and 16 mm.  
The cable glands supplied are made of brass and certified Ex d.

### C9.4 - TYPE OF ADAPTABLE CABLE GLANDS ON TYPE "e" TERMINAL BOX FOR FLSD FLAMEPROOF - (F) LSE INCREASED SAFETY - (F)LSN NON-SPARKING MOTORS

Terminal box for frame size	Standard cable gland	
	Type	Permissible cable Ø (mm)
(F)LSE - (F)LSN 80 - 90 - 100 - 112	ISO M20 x 1.5	7.5 to 13
(F)LSE - (F)LSN 132 - LSE - (F)LSN 160	ISO M25 x 1.5	12.5 to 18
LSE - (F)LSN 180 - 200	ISO M32 x 1.5	17.5 to 25
LSE - (F)LSN 225	ISO M40 x 1.5	24.5 to 33.5
LSE - (F)LSN 250	ISO M40 x 1.5	21 to 34
LSE - (F)LSN 250 - 315	ISO M50 x 1.5	33 to 43
FLSN 355	CMA 3" GC	40 to 62

The cable glands supplied are made of brass and cable anchor type certified Ex e  
\* LSE-LSN up to 280

# 3-phase TEFV induction motors ATEX GAS - Zones 1 & 2 Construction



## C9 - Mains connection

### C9.5 - POWER SUPPLY

#### TERMINALS - DIRECTION OF ROTATION

The motors have a block of 6 terminals or isolators.

The terminal markings comply with IEC 60034-8 (or NFC 51 118). When the motor is powered by U1, V1, W1 or 1U, 1V, 1W from a direct mains supply L1, L2, L3, it turns clockwise when seen from the drive shaft end. If 2 phases of the power supply are changed over, the motor will run in an anti-clockwise direction (make sure the motor has been designed to run in both directions of rotation). If the motor is fitted with thermal protection or space heaters, these are connected in the main terminal box to auxiliary terminal blocks compatible with the box protection type.

#### C9.5.1 - Terminal block

The terminal blocks are selected according to the motor rated current, the supply voltage and the protection method («d» or «e»), «n» motors being fitted with type «e» boxes.

The terminals must be tightened sufficiently with a torque wrench to avoid any risk of electric arcs or mechanical breakdown, as indicated in the table below.

#### FLSD with "d" or "e" terminal box

Frame size	Terminals	Material	Tightening torque (Nm)
80L to 112M	M5	steel	3.5
132S & 132M	M6	steel	5
160M to 225M	M8	steel	10
250M & 280M	M10	steel	20
315S & 355L	M12	steel	35

#### FLSE-FLSN

Frame size	Terminals	Material	Tightening torque (Nm)
80 to 112	M5	steel	3.2
132	M6	steel	5
160 to 225	M8	steel	10
225 to 250	M10	steel	20
280 S to 355 L	M12	steel	35
355 LK	M14	steel	50

### C9.6 - WIRING DIAGRAMS

All motors are supplied with a wiring diagram in the terminal box.

The diagrams normally used are shown opposite.

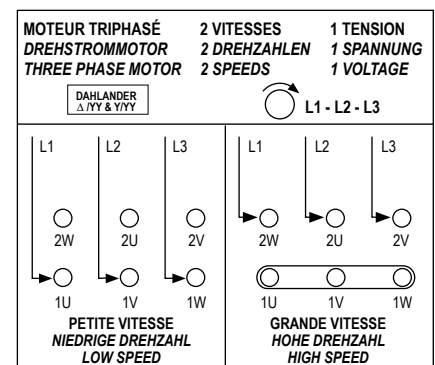
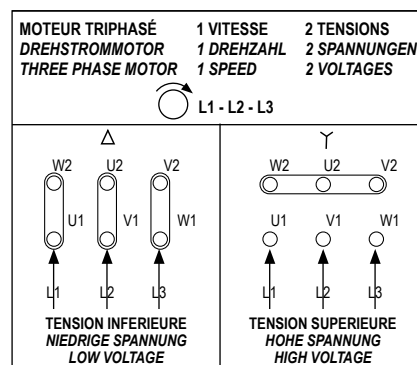

### C9.7 - EARTH TERMINALS

In accordance with general safety standards for machines, the motors are fitted with one earth terminal inside the terminal box and

another on the outside, on one of the motor feet, flange or casing.

They are marked:  $\perp$

# 3-phase TEFV induction motors ATEX GAS - Zones 1 & 2 Operation



## D1 - Weighted sound level [dB(A)]

Under IEC 60034-9, the guaranteed values are given for a machine operating at no-load under normal supply conditions (IEC 60034-1), in the actual operating position, or sometimes in the direction of rotation as specified in the design.

This being the case, standardized sound power level limits are shown for the values obtained for the machines described in this catalogue.

(Measurements were taken in conformity with standard ISO 1680).

Expressed as sound power level ( $L_w$ ) according to the standard, the level of sound is also shown as sound pressure level ( $L_p$ ) in the selection data.

The maximum standard tolerance for all these values is + 3 dB(A).



The noise levels of the motors in this catalogue are indicated in the pages relating to the technical characteristics in selection data.

# 3-phase TEFV induction motors ATEX GAS - Zones 1 & 2 Operation



## D2 - Motor vibration levels - Balancing

Inaccuracies due to construction (magnetic, mechanical and air-flow) lead to sinusoidal (or pseudo sinusoidal) vibrations over a wide range of frequencies. Other sources of vibration can also affect motor operation: such as poor mounting, incorrect drive coupling, end shield misalignment, etc.

We shall first of all look at the vibrations emitted at the operating frequency, corresponding to an unbalanced load, whose amplitude swamps all other frequencies and on which the dynamic balancing of the mass in rotation has a decisive effect.

Under standard ISO 8821, rotating machines can be balanced with or without a key or with a half-key on the shaft extension.

Standard ISO 8821 requires the balancing method to be marked on the shaft extension as follows:

- Half-key balancing: letter H
- Full key balancing: letter F
- No-key balancing: letter N

The machines in this catalogue are classed as level A balancing - level B is available on request.

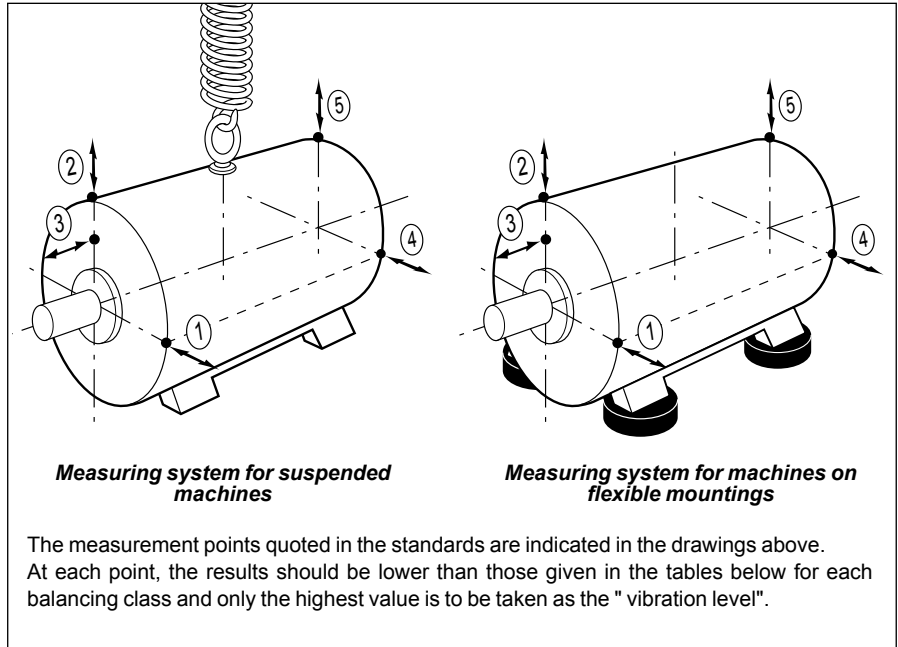

### Measured parameters

The vibration speed can be chosen as the variable to be measured. This is the speed at which the machine moves either side of its static position. It is measured in mm/s.

As the vibratory movements are complex and non-harmonic, it is the root mean square (rms) value of the speed of vibration which is used to express the vibration level.

Other variables that could also be measured are the vibratory displacement amplitude (in  $\mu\text{m}$ ) or vibratory acceleration (in  $\text{m/s}^2$ ).

If the vibratory displacement is measured against frequency, the measured value decreases with the frequency: high-frequency vibrations cannot be measured here.

If the vibratory acceleration is measured, the measured value increases with the frequency: low-frequency vibrations (unbalanced loads) cannot be measured here.

The rms speed of vibration is the variable chosen by the standards.

However, if preferred, the table of vibration amplitudes may still be used (for measuring sinusoidal and similar vibrations).

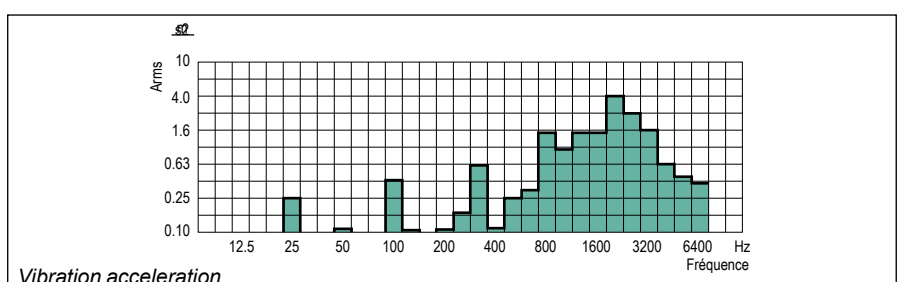
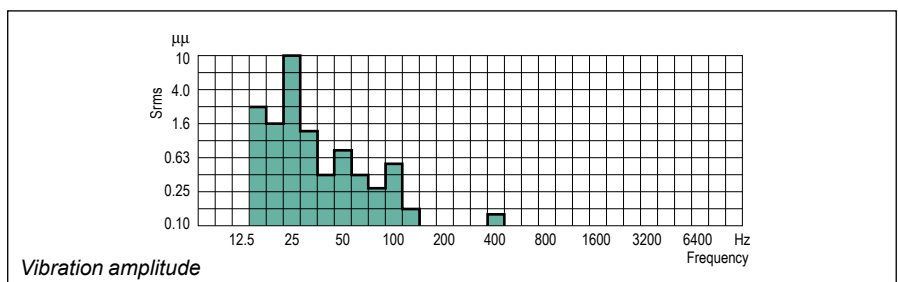
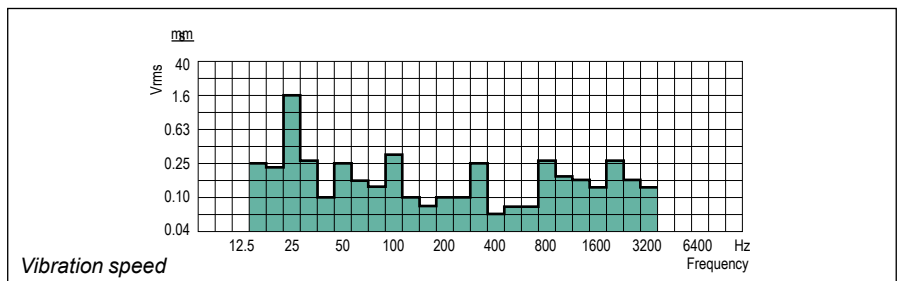

# 3-phase TEFV induction motors ATEX GAS - Zones 1 & 2 Operation



## D2 - Motor vibration levels - Balancing

Maximum vibration magnitude limits (rms values) in terms of displacement, speed and acceleration for a frame size H (IEC 60034-14)

Vibration level	Frame size $H$ (mm)								
	$56 < H \leq 132$			$132 < H \leq 280$			$H > 280$		
	Displacement $\mu\text{m}$	Speed mm/s	Acceleration $\text{m/s}^2$	Displacement $\mu\text{m}$	Speed mm/s	Acceleration $\text{m/s}^2$	Displacement $\mu\text{m}$	Speed mm/s	Acceleration $\text{m/s}^2$
A	25	1.6	2.5	35	2.2	3.5	45	2.8	4.4
B	11	0.7	1.1	18	1.1	1.7	29	1.8	2.8

For large machines and special requirements with regard to vibration, balancing can be carried out *in situ* (finished assembly).

Prior consultation is essential, as the machine dimensions may be modified by the necessary addition of balancing disks mounted on the shaft extensions.



# TEFV induction motors FLSD flameproof - Zone 1 Electromechanical characteristics



PAGE

## E1 - Selection data

E1.1 - 2 poles - 3000 min <sup>-1</sup> .....	44
E1.2 - 4 poles - 1500 min <sup>-1</sup> .....	45
E1.3 - 6 poles - 1000 min <sup>-1</sup> .....	46
E1.4 - 8 poles - 750 min <sup>-1</sup> .....	47

## E2 - Dimensions

E2.1 - Shaft extensions .....	48
E2.2 - Foot mounted <b>IM B3 (IM 1001)</b> .....	49
E2.3 - Foot and flange mounted <b>IM B35 (IM 2001)</b> .....	50
E2.4 - Flange mounted <b>IM B5 (IM 3001) IM V1 (IM 3011)</b> .....	51
E2.5 - Foot and face mounted <b>IM B34 (IM 2101)</b> .....	52
E2.6 - Face mounted <b>IM B14 (IM 3601)</b> .....	53

# TEFV induction motors FLSD flameproof - Zone 1 Selection data



## E1.1 - 2 poles - 3000 min<sup>-1</sup>

**2**  
poles  
3000 min<sup>-1</sup>

Ex d IIB T4

IP 55  
Cl. F - ΔT 80K  
400 V ± 10%

### MAINS SUPPLY Δ 230 / Y 400 V or Δ 400 V 50 Hz

Type	Rated power	Rated speed	Rated torque	Rated current	Power factor			Efficiency IEC 60034-2; 1996			Starting current/ Rated current	Starting torque/ Rated torque	Maximum torque/ Rated torque	Moment of inertia	Weight	Noise
	P <sub>N</sub> kW	N <sub>N</sub> min <sup>-1</sup>	M <sub>N</sub> N.m	I <sub>N(400V)</sub> A	Cos φ			η			Id/In	Md/Mn	M <sub>m</sub> /Mn	J kg.m <sup>2</sup>	IM B3 kg	LP db(A)
FLSD 80 L	0.75	2860	2.51	1.6	0.89	0.84	0.75	78.4	78.5	75.4	5.4	2.9	2.6	0.00087	23	61
FLSD 80 L	1.1	2850	3.67	2.4	0.84	0.77	0.64	77.8	77.9	75.5	6.1	3.4	3.1	0.00087	23	61
FLSD 90 S	1.5	2867	4.99	3	0.88	0.84	0.74	80.9	81.1	77.3	7.4	3.5	3.3	0.00171	31	64
FLSD 90 L	2.2	2849	7.37	4.4	0.88	0.84	0.74	81.4	81.6	79.2	7.8	3.9	2.9	0.00199	32	64
FLSD 100 L	3	2865	10	6.2	0.85	0.81	0.67	81.26	80.5	77.8	7.6	4.3	4.8	0.00227	38	66
FLSD 112 M	4	2891	13.2	8	0.86	0.8	0.7	82.9	82.6	79.7	7.0	2.3	3.9	0.00652	47	69
FLSD 132 S	5.5	2898	18.1	10.9	0.87	0.86	0.83	86.1	86.2	84	8.1	2.3	3.4	0.01191	76	72
FLSD 132 S	7.5	2920	24.5	14.8	0.84	0.81	0.73	86.3	86.6	85.03	7.5	2.1	3.5	0.01443	81	72
FLSD 132 M	9	2938	29.3	16.8	0.89	0.82	0.73	87.2	86.8	84.1	8.3	2.9	3.5	0.01847	88	72
FLSD 132 M	11	2934	35.8	21	0.85	0.79	0.69	87.1	86.5	84	8.2	3.5	3.4	0.01847	88	72
FLSD 160 M	11	2940	35.7	21	0.87	0.85	0.81	86	86	84.1	7.6	3.3	3.2	0.044	125	84
FLSD 160 M	15	2930	49	28	0.88	0.86	0.82	88	88	85.4	7.9	3.4	3.3	0.0515	137	84
FLSD 160 L	18.5	2930	60	34	0.88	0.86	0.82	88.5	88.2	85.3	8.3	3.4	3.4	0.059	170	84
FLSD 180 M	22	2935	72	40	0.88	0.85	0.82	89	89.1	87	9.1	4.1	3.8	0.075	180	85
FLSD 200 L	30	2960	97	53	0.9	0.87	0.82	91	89.8	87.2	9.1	3.0	3.5	0.142	305	85
FLSD 200 L	37	2960	119	65	0.9	0.88	0.81	91.5	91.5	88	8.7	2.9	3.3	0.163	325	85
FLSD 225 M	45	2949	145	77	0.91	0.88	0.82	92.5	92.4	91	8.8	2.9	3.4	0.204	365	83
FLSD 250 M	55	2951	177	99	0.85	0.83	0.77	94.6	94.5	93.9	7.7	2.6	2.7	0.223	490	82
FLSD 280 S	75	2970	241	127	0.9	0.85	0.81	94.5	93.1	94.5	6.8	2.2	2.4	0.75	760	76
FLSD 280 M	90	2975	289	152	0.9	0.86	0.8	95	94.9	94	7.4	2.3	2.5	0.85	800	76
FLSD 315 S	110	2970	353	188	0.89	0.86	0.8	95.2	94.9	94	8.0	2.1	2.6	1.5	1070	84
FLSD 315 M	132	2955	427	229	0.87	0.84	0.79	95.5	94.9	94.1	8.7	2.4	2.7	1.5	1070	84
FLSD 315 LA	160	2955	517	279	0.87	0.85	0.81	95.4	94.8	93.5	7.0	1.9	2.6	1.8	1120	84
FLSD 315 LB	200	2960	645	345	0.88	0.85	0.79	95.3	94.6	93.4	8.0	2.3	2.6	2.1	1220	84
FLSD 355 LA	250	2957	807	421	0.9	0.86	0.81	95.2	94.5	93.3	7.8	1.7	2.5	3.3	1470	84
FLSD 355 LB	315	2960	1016	530	0.9	0.86	0.8	95.5	94.9	94.2	7.2	1.6	2.5	3.85	1570	84
FLSD 355 LC	355	2982	1137	605	0.88	0.86	0.8	96.3	96	95	7.9	1.9	2.6	4.2	1985	84
FLSD 355 LD	400	2980	1282	676	0.89	0.85	0.8	96.3	95.9	94.8	7.8	2.0	2.7	4.2	1995	84

The values described also apply to the Ex d IIC T4 finish.  
For T5 applications, please consult Leroy-Somer.

# TEFV induction motors FLSD flameproof - Zone 1 Selection data



E1.2 - 4 poles - 1500 min<sup>-1</sup>

**4**  
poles  
1500 min<sup>-1</sup>

Ex d IIB T4

IP 55  
Cl. F - ΔT 80K  
400 V ± 10%

MAINS SUPPLY Δ 230 / Y 400 V or Δ 400 V 50 Hz

Type	Rated power	Rated speed	Rated torque	Rated current	Power factor			Efficiency IEC 60034-2; 1996			Starting current/ Rated current	Starting torque/ Rated torque	Maximum torque/ Rated torque	Moment of inertia	Weight	Noise
	P <sub>N</sub> kW	N <sub>N</sub> min <sup>-1</sup>	M <sub>N</sub> N.m	I <sub>N(400V)</sub> A	Cos φ			η			Id/In	Md/Mn	M <sub>m</sub> /Mn	J kg.m <sup>2</sup>	IM B3 kg	LP db(A)
FLSD 80 L	0.55	1430	3.67	1.45	0.7	0.61	0.5	74	72.8	68.3	5.0	2.9	3.3	0.00167	22	44
FLSD 80 L	0.75	1420	5	2	0.74	0.66	0.54	75.1	74.1	69.7	5.4	3.1	3.6	0.00212	24	44
FLSD 90 S	1.1	1427	7.4	2.4	0.86	0.79	0.67	76.1	76.4	73.4	5.0	1.8	2.3	0.00264	28	50
FLSD 90 L	1.5	1432	10	3.23	0.86	0.79	0.65	77.8	77.9	75	5.4	2.0	2.7	0.00321	30	50
FLSD 100 L	2.2	1435	14.6	4.6	0.85	0.78	0.65	80.5	80.4	77.6	6.1	2.5	3.1	0.00432	38	52
FLSD 100 L	3	1439	20	6.8	0.806	0.74	0.61	81.2	81.2	78.7	6.6	2.7	3.1	0.00557	41	52
FLSD 112 M	4	1458	26.2	8.5	0.81	0.76	0.67	84.6	84.3	82	7.5	2.3	3.2	0.01226	51	52
FLSD 132 S	5.5	1450	36.2	10	0.89	0.87	0.81	86.8	87.3	86.2	7.0	2.3	2.4	0.02507	89	59
FLSD 132 M	7.5	1460	49.1	14.7	0.85	0.84	0.8	87.8	88.2	87.2	7.7	2.3	3.1	0.02776	93	59
FLSD 160 M	11	1450	73	21	0.85	0.79	0.71	87.5	87.7	86.5	6.2	2.4	2.5	0.0666	130	66
FLSD 160 L	15	1450	99	29	0.85	0.82	0.72	88.5	88.6	87.7	6.9	2.3	2.4	0.0913	155	66
FLSD 180 M	18.5	1450	122	35	0.85	0.83	0.74	89.5	89.5	88.7	7.2	3.0	3.1	0.1053	175	68
FLSD 180 L	22	1455	145	42	0.85	0.81	0.71	89.5	89.5	88.9	7.6	3.0	3.1	0.1205	195	68
FLSD 200 L	30	1470	195	56	0.84	0.79	0.67	91.5	91.6	90.2	7.5	2.8	2.9	0.2147	305	74
FLSD 225 S	37	1470	241	69	0.84	0.78	0.69	92	91.4	89.7	7.7	2.9	2.8	0.2613	330	73
FLSD 225 M	45	1470	293	84	0.84	0.8	0.7	92.5	92.5	91.2	7.8	3.0	2.8	0.3136	365	73
FLSD 250 M	55	1480	355	101	0.85	0.79	0.69	92.5	92.6	91.6	7.8	2.5	2.6	0.399	540	80
FLSD 280 S	75	1487	484	141	0.81	0.75	0.65	95.2	94.8	93.5	8.2	3.3	2.6	1.45	780	70
FLSD 280 M	90	1488	581	169	0.81	0.75	0.65	95	94.5	93	10.0	3.3	2.6	1.75	830	70
FLSD 315 S	110	1482	710	199	0.84	0.81	0.73	95	94.5	93	7.7	2.7	2.6	2.7	1070	73
FLSD 315 M	132	1483	850	238	0.84	0.8	0.72	95.2	94.8	93.7	7.4	2.8	2.6	2.7	1070	73
FLSD 315 LA	160	1483	1032	286	0.85	0.82	0.72	95	94.4	93	7.0	2.0	2.4	3.2	1120	73
FLSD 315 LB	200	1485	1291	357	0.85	0.8	0.69	95.2	94.8	93.6	9.0	2.8	3.0	4.1	1220	73
FLSD 355 LA	250	1483	1611	420	0.9	0.86	0.78	95.5	95.2	94	7.8	2.0	2.4	6.9	1580	80
FLSD 355 LB	300	1489	1930	520	0.87	0.84	0.77	95.7	95.4	94.2	6.7	1.6	2.4	8	1630	80
FLSD 355 LC	355	1489	2279	610	0.87	0.84	0.78	96.5	96.3	95.1	6.8	1.8	2.4	8.4	1870	80
FLSD 355 LD	400	1489	2564	688	0.87	0.83	0.77	96.5	96.3	95	7.4	2.1	2.4	8.7	1990	80

The values described also apply to the Ex d IIC T4 finish.  
For T5 applications, please consult Leroy-Somer.

# TEFV induction motors FLSD flameproof - Zone 1 Selection data



## E1.3 - 6 poles - 1000 min<sup>-1</sup>



Ex d IIB T4

IP 55  
Cl. F - ΔT 80K  
400 V ± 10%

### MAINS SUPPLY Δ 230 / Y 400 V or Δ 400 V 50 Hz

Type	Rated power	Rated speed	Rated torque	Rated current	Power factor			Efficiency IEC 60034-2; 1996			Starting current/ Rated current	Starting torque/ Rated torque	Maximum torque/ Rated torque	Moment of inertia	Weight	Noise
	P <sub>N</sub> kW	N <sub>N</sub> min <sup>-1</sup>	M <sub>N</sub> N.m	I <sub>N(400V)</sub> A	Cos φ			η			Id/In	Md/Mn	M <sub>m</sub> /Mn	J kg.m <sup>2</sup>	IM B3 kg	LP db(A)
FLSD 80 L	0.25	950	2.51	0.8	0.74	0.68	0.55	60.3	58.2	54.0	3.6	2.0	1.9	0.0022	22	40
FLSD 80 L	0.37	940	3.76	1.2	0.74	0.68	0.55	61.0	59.9	55.2	3.8	1.9	2.1	0.0028	24	40
FLSD 80 L	0.55	955	5.5	1.8	0.67	0.59	0.46	65.1	64.0	59.0	4.4	2.5	2.6	0.0036	24	40
FLSD 90 S	0.75	940	7.62	2.1	0.8	0.75	0.65	70.5	69.3	63.5	3.5	2.0	2.2	0.0031	28	45
FLSD 90 L	1.1	940	11.2	2.7	0.81	0.76	0.66	70.7	71.0	66.7	4.8	1.8	2.2	0.0037	30	45
FLSD 100 L	1.5	955	15	3.5	0.78	0.72	0.61	75.7	76.4	75.2	6.3	2.2	2.8	0.0056	38	48
FLSD 112 M	2.2	960	21.9	5.2	0.77	0.71	0.59	77.7	78.2	76.3	5.5	2.3	2.4	0.012	51	48
FLSD 132 S	3	953	30.1	6.9	0.76	0.74	0.63	79.7	81.0	79.7	5.3	2.2	2.4	0.0199	89	55
FLSD 132 M	4	970	39.4	9	0.78	0.72	0.61	82.4	83.3	81.9	6.7	2.8	2.7	0.0275	93	55
FLSD 132 M	5.5	970	54.1	12.2	0.79	0.74	0.63	83.1	84.0	82.7	7.1	3.2	2.7	0.0343	93	55
FLSD 160 M	7.5	965	75	17	0.76	0.70	0.58	86.0	85.7	83.6	5.5	2.0	2.6	0.085	125	58
FLSD 160 L	11	970	109	24	0.77	0.72	0.59	87.0	86.7	84.5	6.1	2.1	2.8	0.118	145	58
FLSD 180 L	15	970	148	34	0.74	0.67	0.53	87.0	86.1	84.0	6.8	2.2	2.4	0.158	180	60
FLSD 200 L	18.5	975	182	37	0.8	0.75	0.5	90.0	90.1	85.6	7.5	1.9	2.7	0.305	305	66
FLSD 200 L	22	970	217	45	0.79	0.73	0.62	90.0	90.2	89.9	7.5	2.2	3.2	0.305	305	66
FLSD 225 M	30	970	295	60	0.8	0.73	0.6	90.0	89.5	87.3	7.7	2.3	3.1	0.394	350	65
FLSD 250 M	37	982	360	74.5	0.78	0.73	0.6	92.0	91.9	90.4	7.2	2.4	2.2	0.56	530	71
FLSD 280 S	45	987	440	83	0.87	0.84	0.76	93.9	94.0	93.0	6.1	1.9	2.3	1.1	780	72
FLSD 280 M	55	987	536	100	0.84	0.8	0.71	95.0	94.9	94.0	6.4	2.1	2.4	1.25	830	72
FLSD 315 S	75	987	731	130	0.87	0.83	0.77	95.0	95.0	94.1	7.2	1.7	2.3	3.1	1080	76
FLSD 315 M	90	983	875	161	0.86	0.83	0.75	94.0	93.9	92.5	7.1	1.5	2.5	3.1	1080	76
FLSD 315 LA	110	985	1067	197	0.86	0.82	0.74	94.3	93.0	86.0	6.8	1.6	2.5	4	1130	76
FLSD 315 LB	132	986	1280	234	0.86	0.83	0.74	94.9	94.7	93.3	7.5	1.7	2.5	4.4	1195	76
FLSD 315 LB	150	985	1454	265	0.86	0.82	0.72	94.7	94.4	93.0	6.8	1.5	2.4	4.4	1215	76
FLSD 355 LA	185	991	1783	329	0.86	0.83	0.74	94.2	94.2	93.1	7.5	1.7	2.7	5	1485	78
FLSD 355 LB	220	987	2129	384	0.87	0.84	0.75	95.0	95.0	93.7	7.5	1.8	2.7	6	1610	78
FLSD 355 LD	300	993	2885	553	0.82	0.79	0.71	95.5	95.3	94.0	7.6	1.6	2.6	8	1995	78

The values described also apply to the Ex d IIC T4 finish.  
For T5 applications, please consult Leroy-Somer.

# TEFV induction motors FLSD flameproof - Zone 1 Selection data



E1.4 - 8 poles - 750 min<sup>-1</sup>

**8**  
poles  
750 min<sup>-1</sup>

Ex d IIB T4

IP 55  
Cl. F - ΔT 80K  
400 V ± 10%

MAINS SUPPLY Δ 230 / Y 400 V or Δ 400 V 50 Hz

Type	Rated power	Rated speed	Rated torque	Rated current	Power factor			Efficiency IEC 60034-2; 1996			Starting current/ Rated current	Starting torque/ Rated torque	Maximum torque/ Rated torque	Moment of inertia	Weight	Noise
	P <sub>N</sub> kW	N <sub>N</sub> min <sup>-1</sup>	M <sub>N</sub> N.m	I <sub>N(400V)</sub> A	Cos φ			η			Id/In	Md/Mn	M <sub>m</sub> /Mn	J kg.m <sup>2</sup>	IM B3 kg	LP db(A)
FLSD 80 L	0.18	710	2.42	0.8	0.64	0.58	0.46	52.3	51	45	3	1.7	1.7	0.0028	22	40
FLSD 80 L	0.25	720	3.32	1.1	0.6	0.55	0.44	54.5	54	46	3.18	2.0	2.4	0.0036	24	40
FLSD 90 S	0.37	685	5.16	1.2	0.71	0.57	0.45	64	63	59	3.5	1.6	1.6	0.0031	28	48
FLSD 90 L	0.55	695	7.56	1.7	0.72	0.59	0.46	63	58	54	3.29	1.8	1.8	0.0037	30	48
FLSD 100 L	0.75	720	9.95	2.3	0.68	0.6	0.47	70.9	70	66	4.09	1.9	1.9	0.0085	38	46
FLSD 100 L	1.1	720	14.6	3.8	0.62	0.56	0.44	68	66	60	4.11	1.8	2.4	0.0117	41	46
FLSD 112 M	1.5	725	19.8	4.8	0.63	0.57	0.45	72.5	72	68	4	2.1	2.2	0.0150	51	49
FLSD 132 S	2.2	715	29.4	7.2	0.6	0.55	0.44	74	74	72	3.19	1.4	1.8	0.0253	89	56
FLSD 132 M	3	705	40.6	9.1	0.63	0.57	0.46	76	76	73	3.1	1.3	1.9	0.0334	93	56
FLSD 160 M	4	724	54	11	0.65	0.58	0.46	82.0	81.7	80.2	3.7	2.1	2.0	0.0761	140	58
FLSD 160 M	5.5	710	75	15	0.65	0.58	0.47	82	82.1	80.6	3.6	2.0	1.9	0.0761	140	58
FLSD 160 L	7.5	710	102	21	0.63	0.56	0.45	82.0	82.4	81.0	3.8	2.2	2.0	0.0913	155	58
FLSD 180 L	11	710	148	31	0.63	0.54	0.43	82.0	82.5	81.0	3.9	1.9	2.0	0.1205	195	60
FLSD 200 L	15	725	198	34	0.72	0.65	0.52	89.0	88.3	86.5	5.4	1.9	2.4	0.39	305	66
FLSD 225 S	18.5	725	244	43	0.7	0.64	0.53	88.5	88.5	86.9	5.5	2.0	2.5	0.393	320	65
FLSD 225 M	22	725	290	50	0.71	0.67	0.57	88.5	88.7	87.2	5.3	1.9	2.4	0.466	350	65
FLSD 250 M	30	733	391	61	0.78	0.74	0.64	91.3	91.4	90.5	5.5	1.6	2.0	0.57	530	71
FLSD 280 S	37	740	480	72	0.8	0.73	0.63	93.9	94.2	93.7	7.0	1.8	2.3	1.6	780	72
FLSD 280 M	45	741	585	90	0.77	0.72	0.63	94.0	93.2	91.4	7.5	2.0	2.3	1.75	810	72
FLSD 315 S	55	743	715	108	0.78	0.72	0.63	94.8	94.8	94.1	7.3	2.0	2.5	3.1	1070	78
FLSD 315 M	75	737	972	140	0.83	0.74	0.65	93.5	93.8	93.2	7.4	2.0	2.6	3.1	1070	78
FLSD 315 LA	90	735	1169	167	0.83	0.74	0.64	94.0	94.2	93.5	7.3	2.0	2.5	4.2	1100	78
FLSD 315 LB	110	740	1420	204	0.82	0.74	0.63	94.2	94.1	93.3	7.2	1.6	2.2	5.1	1195	78
FLSD 355 LA	132	740	1703	244	0.83	0.75	0.64	94.2	94.3	93.4	6.7	1.7	2.7	5.5	1485	78
FLSD 355 LB	160	740	2065	296	0.82	0.74	0.63	95.2	95.0	93.5	6.9	1.8	2.7	6	1605	78
FLSD 355 LD	200	740	2581	360	0.84	0.75	0.65	95.4	95.2	93.6	6.7	1.6	2.6	6.5	1995	78

The values described also apply to the Ex d IIC T4 finish.  
For T5 applications, please consult Leroy-Somer.

# TEFV induction motors FLSD flameproof - Zone 1 Dimensions



## E2.1 - Shaft extensions

Dimensions in millimetres

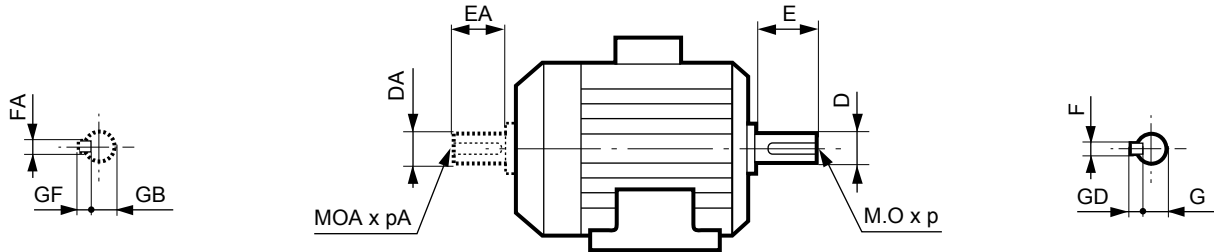

Type	Main shaft extensions													
	4, 6 and 8 poles							2 poles						
	F	GD	D	G	E	O	p	F	GD	D	G	E	O	p
FLSD 80 L	6	6	19j6	15.5	40	6	16	6	6	19j6	15.5	40	6	16
FLSD 90 S/L	8	7	24j6	20	50	8	19	8	7	24j6	20	50	8	19
FLSD 100 L	8	7	28j6	24	60	10	22	8	7	28j6	24	60	10	22
FLSD 112 M	8	7	28j6	24	60	10	22	8	7	28j6	24	60	10	22
FLSD 132 S/M	10	8	38k6	33	80	12	28	10	8	38k6	33	80	12	28
FLSD 160 M/L	12	8	42k6	37	110	16	36	12	8	42k6	37	110	16	36
FLSD 180 M/L	14	9	48k6	42.5	110	16	36	14	9	48k6	42.5	110	16	36
FLSD 200 L	16	10	55m6	49	110	20	42	16	10	55m6	49	110	20	42
FLSD 225 S/M	18	11	60m6	53	140	20	42	16	10	55m6	49	110	20	42
FLSD 250 M	18	11	65m6	58	140	20	42	18	11	60m6	53	140	20	42
FLSD 280 S/M	20	12	75m6	67.5	140	20	53	18	11	65m6	58	140	20	53
FLSD 315 S/M	22	14	80m6	71	170	20	53	18	11	65m6	58	140	20	53
FLSD 315 L	25	14	90m6	81	170	24	53	20	12	70m6	62.5	140	20	53
FLSD 355 L	28	16	100m6	90	210	24	53	22	14	80m6	71	170	20	53

Type	Secondary shaft extensions													
	4, 6 and 8 poles							2 poles						
	FA	GF	DA	GB	EA	OA	pA	FA	GF	DA	GB	EA	OA	pA
FLSD 80 L	5	5	16j6	13	40	5	12	5	5	16j6	13	40	5	12
FLSD 90 S/L	8	7	24j6	20	50	8	19	8	7	24j6	20	50	8	19
FLSD 100 L	8	7	24j6	20	50	8	19	8	7	24j6	20	50	8	19
FLSD 112 M	8	7	28j6	24	60	10	22	8	7	28j6	24	60	10	22
FLSD 132 S/M	10	8	38k6	33	80	12	28	10	8	38k6	33	80	12	28
FLSD 160 M/L	12	8	42k6	37	110	16	36	12	8	42k6	37	110	16	36
FLSD 180 M/L	14	9	48k6	42.5	110	16	36	14	9	48k6	42.5	110	16	36
FLSD 200 L	16	10	55m6	49	110	20	42	16	10	55m6	49	110	20	42
FLSD 225 S/M	16	10	55m6	49	110	20	42	16	10	55m6	49	110	20	42
FLSD 250 M	18	11	60m6	58	140	20	42	18	11	60m6	53	140	20	42
FLSD 280 S/M	20	12	60m6	67.5	140	20	53	18	11	65m6	58	140	20	53
FLSD 315 S/M	22	14	80m6	71	170	20	53	18	11	65m6	58	140	20	53
FLSD 315 L	25	14	90m6	81	170	24	53	20	12	70m6	62.5	140	20	53
FLSD 355 L	28	16	100m6	90	210	24	53	22	14	80m6	71	170	20	53

# TEFV induction motors FLSD flameproof - Zone 1 Dimensions



## E2.2 - Foot mounted IM B3 (IM 1001)

Dimensions in millimetres

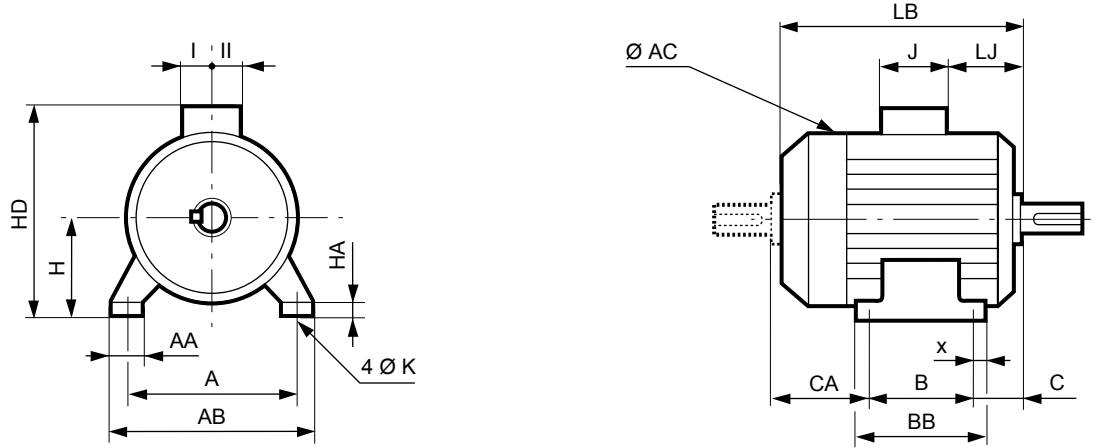

Type	Main dimensions																
	A	AB	B	BB	C	X	AA	K	HA	H	HD	LB	LJ	J	I	II*	
FLSD 80 L	125	157	100	132	50	10	34	9	10	80	167	283	258	26	142	71	77
FLSD 90 S	140	170	100	155	56	11	33	12	10	90	184	306	297	32	142	71	77
FLSD 90 L	140	170	125	155	56	11	33	12	10	90	184	306	297	32	142	71	77
FLSD 100 L	160	196	140	201	63	19	40	12	13	100	195	316	345	32	142	71	77
FLSD 112 M	190	230	140	186	70	14	47	12	14	112	220	357	346	34	142	71	77
FLSD 132 S	216	255	140	243	89	14	63	12	16	132	264	371	462	56	142	71	77
FLSD 132 M	216	256	178	243	89	14	63	12	16	132	264	371	462	56	142	71	77
FLSD 160 M	254	310	210	322	108	30	75	15	18	160	310	490	549	19	250	125	145
FLSD 160 L	254	310	254	322	108	30	75	15	18	160	310	490	549	19	250	125	145
FLSD 180 M	279	340	241	364	121	30	80	15	20	180	310	510	617	19	250	125	145
FLSD 180 L	279	340	279	364	121	30	80	15	20	180	310	510	617	19	250	125	145
FLSD 200 L	318	380	305	385	133	40	90	19	24	200	385	565	648	33	250	125	145
FLSD 225 S	356	445	286	400	149	44	90	19	30	225	385	590	718	33	250	125	145
FLSD 225 M	356	445	311	400	149	44	90	19	30	225	385	590	718	33	250	125	145
FLSD 250 M	406	510	349	455	168	43	105	22	40	250	465	720	827	173	360	208	208
FLSD 280 S	457	537	368	499	190	40	80	22	40	280	540	768	1065	77	330	165	271
FLSD 280 M	457	537	419	499	190	40	80	22	40	280	540	768	1065	77	330	165	271
FLSD 315 S	508	600	406	598	216	45	100	27	38	315	624	952	1203	96	400	195	340
FLSD 315 M	508	600	457	598	216	45	100	27	38	315	624	952	1203	96	400	195	340
FLSD 315 LA/LB	508	600	508	598	216	45	100	27	38	315	624	952	1203	96	400	195	340
FLSD 355 LA/LB	610	710	630	710	254	40	110	27	38	355	700	1027	1302	88	400	195	340
FLSD 355 LC/LD	610	710	630	710	254	40	110	27	38	355	700	1027	1426	88	400	195	340

\* Dimensions not including cable gland

# TEFV induction motors FLSD flameproof - Zone 1 Dimensions



## E2.3 - Foot and flange mounted IM B35 (IM 2001)

Dimensions in millimetres

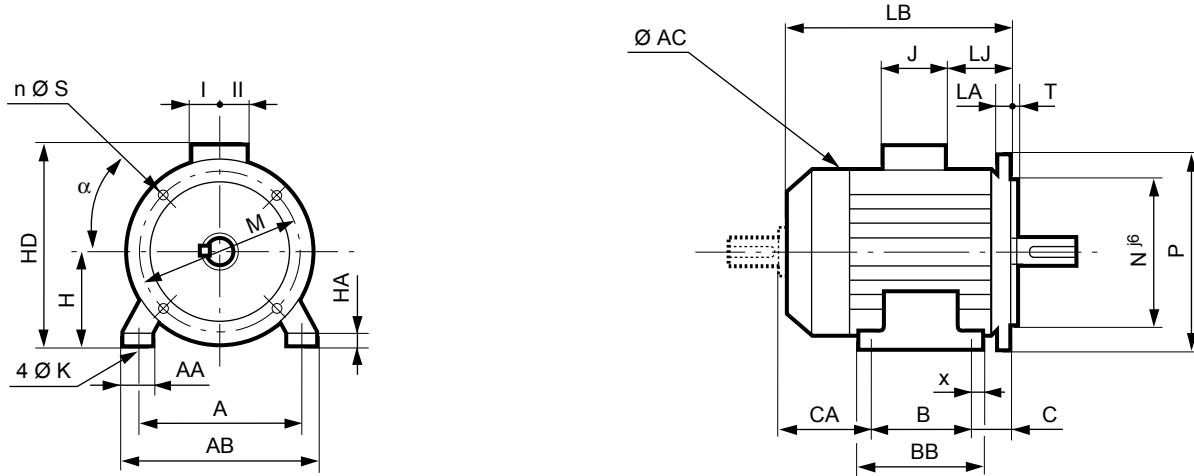

Type	Main dimensions																	
	A	AB	B	BB	C	X	AA	K	HA	H	AC	HD	LB	LJ	J	I	II*	Symbol
FLSD 80 L	125	157	100	132	50	10	34	9	10	80	167	283	258	26	142	71	77	FF165
FLSD 90 S	140	170	100	155	56	11	33	12	10	90	184	306	297	32	142	71	77	FF165
FLSD 90 L	140	170	125	155	56	11	33	12	10	90	184	306	297	32	142	71	77	FF165
FLSD 100 L	160	196	140	201	63	19	40	12	13	100	195	316	345	32	142	71	77	FF215
FLSD 112 M	190	230	140	186	70	14	47	12	14	112	220	357	346	34	142	71	77	FF215
FLSD 132 S	216	255	140	243	89	14	63	12	16	132	264	371	462	56	142	71	77	FF265
FLSD 132 M	216	256	178	243	89	14	63	12	16	132	264	371	462	56	142	71	77	FF265
FLSD 160 M	254	310	210	322	108	30	75	15	18	160	310	490	549	19	250	125	145	FF300
FLSD 160 L	254	310	254	322	108	30	75	15	18	160	310	490	549	19	250	125	145	FF300
FLSD 180 M	279	340	241	364	121	30	80	15	20	180	310	510	617	19	250	125	145	FF300
FLSD 180 L	279	340	279	364	121	30	80	15	20	180	310	510	617	19	250	125	145	FF300
FLSD 200 L	318	380	305	385	133	40	90	19	24	200	385	565	648	33	250	125	145	FF350
FLSD 225 S	356	445	286	400	149	44	90	19	30	225	385	590	718	33	250	125	145	FF400
FLSD 225 M	356	445	311	400	149	44	90	19	30	225	385	590	718	33	250	125	145	FF400
FLSD 250 M	406	510	349	455	168	43	105	22	40	250	465	720	827	173	360	208	208	FF500
FLSD 280 S	457	537	368	499	190	40	80	22	40	280	540	768	1065	77	330	165	271	FF500
FLSD 280 M	457	537	419	499	190	40	80	22	40	280	540	768	1065	77	330	165	271	FF500
FLSD 315 S	508	600	406	598	216	45	100	27	38	315	624	952	1203	96	400	195	340	FF600
FLSD 315 M	508	600	457	598	216	45	100	27	38	315	624	952	1203	96	400	195	340	FF600
FLSD 315 LA/LB	508	600	508	598	216	45	100	27	38	315	624	952	1203	96	400	195	340	FF600
FLSD 355 LA/LB	610	710	630	710	254	40	110	27	38	355	700	1027	1302	88	400	195	340	FF740
FLSD 355 LC/LD	610	710	630	710	254	40	110	27	38	355	700	1027	1426	88	400	195	340	FF740

\* Dimensions not including cable gland

# TEFV induction motors FLSD flameproof - Zone 1 Dimensions



## E2.4 - Flange mounted IM B5 (IM 3001) IM V1 (IM 3011)

Dimensions in millimetres

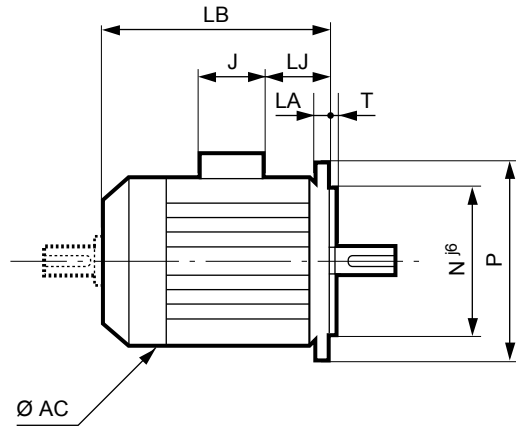
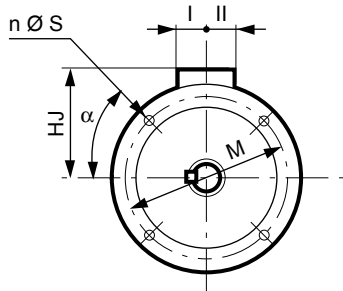

IEC symbol	Flange dimensions							
	M	N	P	T	n	α°	S	LA
FF 165	165	130	200	3.5	4	45	12	10
FF 165	165	130	200	3.5	4	45	12	10
FF 165	165	130	200	3.5	4	45	12	10
FF 215	215	180	250	4	4	45	15	11
FF 215	215	180	250	4	4	45	15	11
FF 265	265	230	300	4	4	45	14.5	13
FF 265	265	230	300	4	4	45	14.5	13
FF 300	300	250	350	5	4	45	18.5	13
FF 300	300	250	350	5	4	45	18.5	13
FF 300	300	250	350	5	4	45	18.5	13
FF 300	300	250	350	5	4	45	18.5	13
FF 350	350	300	400	5	4	45	19	15
FF 400	400	350	450	5	8	22.3	19	16
FF 400	400	350	450	5	8	22.3	19	16
FF 500	500	450	550	5	8	22.3	18	18
FF 500	500	450	550	5	8	22.3	18	22
FF 500	500	450	550	5	8	22.3	18	22
FF 600	600	550	660	6	8	22.3	22	25
FF 600	600	550	660	6	8	22.3	22	25
FF 600	600	550	660	6	8	22.3	22	25
FF 740	740	680	800	6	8	22.3	22	25
FF 740	740	680	800	6	8	22.3	22	25

Type	Main dimensions						
	AC	LB	HJ	LJ	J	I	II*
FLSD 80 L	167	258	203	26	142	71	77
FLSD 90 S	184	297	216	32	142	71	77
FLSD 90 L	184	297	216	32	142	71	77
FLSD 100 L	195	345	216	32	142	71	77
FLSD 112 M	220	346	225	34	142	71	77
FLSD 132 S	264	462	239	56	142	71	77
FLSD 132 M	264	462	239	56	142	71	77
FLSD 160 M	310	549	330	19	250	125	145
FLSD 160 L	310	549	330	19	250	125	145
FLSD 180 M	310	617	330	19	250	125	145
FLSD 180 L	310	617	330	19	250	125	145
FLSD 200 L	385	648	365	33	250	125	145
FLSD 225 S	385	718	365	33	250	125	145
FLSD 225 M	385	718	365	33	250	125	145
FLSD 250 M	465	827	470	173	360	208	208
FLSD 280 S	540	1065	547	77	330	165	271
FLSD 280 M	540	1065	547	77	330	165	271
FLSD 315 S	624	1203	637	96	400	195	340
FLSD 315 M	624	1203	637	96	400	195	340
FLSD 315 LA/LB	624	1203	637	96	400	195	340
FLSD 355 LA/LB	700	1302	672	88	400	195	340
FLSD 355 LC/LD	700	1426	672	88	400	195	340

\* Dimensions not including cable gland

Flange mounted motors FF in position IM 3001 are only available up to frame size 225. See section C4 for mounting arrangements.

# TEFV induction motors FLSD flameproof - Zone 1 Dimensions



## E2.5 - Foot and face mounted IM B34 (IM 2101)

Dimensions in millimetres

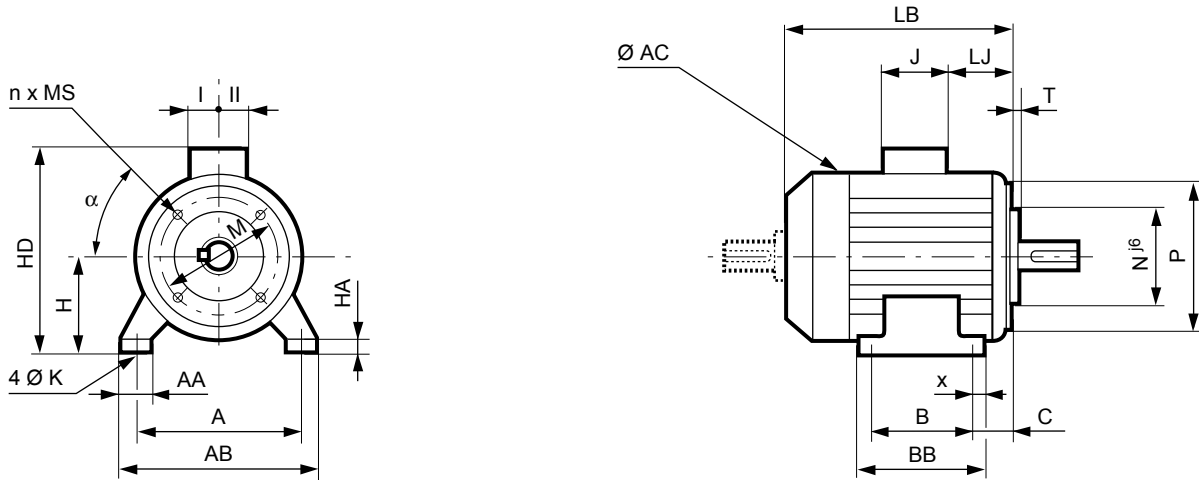

Type	Main dimensions																	
	A	AB	B	BB	C	X	AA	K	HA	H	AC	HD	LB	LJ	J	I	II*	Symbol
FLSD 80 L	125	157	100	132	50	10	34	9	10	80	167	283	258	26	142	71	77	FT100
FLSD 90 S	140	170	100	155	56	11	33	12	10	90	184	306	297	32	142	71	77	FT115
FLSD 90 L	140	170	125	155	56	11	33	12	10	90	184	306	297	32	142	71	77	FT115
FLSD 100 L	160	196	140	201	63	19	40	12	13	100	195	316	345	32	142	71	77	FT130
FLSD 112 M	190	230	140	186	70	14	47	12	14	112	220	357	346	34	142	71	77	FT130
FLSD 132 S	216	255	140	243	89	14	63	12	16	132	264	371	462	56	142	71	77	FT215
FLSD 132 M	216	256	178	243	89	14	63	12	16	132	264	371	462	56	142	71	77	FT215

\* Dimensions not including cable gland

# TEFV induction motors FLSD flameproof - Zone 1 Dimensions



## E2.6 - Face mounted IM B14 (IM 3601)

Dimensions in millimetres

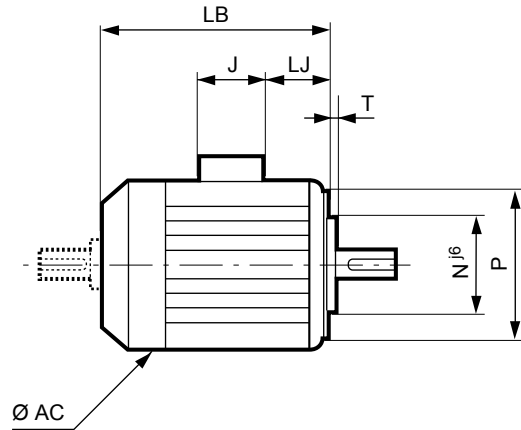
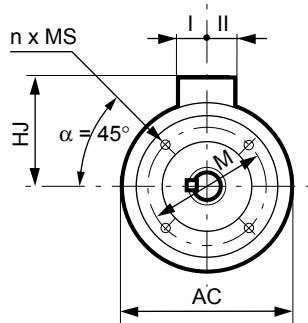

IEC symbol	Faceplate dimensions						
	M	N	P	T	n	$\alpha^\circ$	Thread x length
<b>FT 100</b>	100	80	120	3	4	45	M6 x 13
<b>FT 115</b>	115	95	140	3	4	45	M8 x 13
<b>FT 115</b>	115	95	140	3	4	45	M8 x 13
<b>FT 130</b>	130	110	160	3.5	4	45	M8 x 13
<b>FT 130</b>	130	110	160	3.5	4	45	M8 x 13
<b>FT 215</b>	215	180	250	4	4	45	M12 x 20
<b>FT 215</b>	215	180	250	4	4	45	M12 x 20

Type	Main dimensions						
	AC	LB	HJ	LJ	J	I	II*
<b>FLSD 80 L</b>	167	258	203	26	142	71	77
<b>FLSD 90 S</b>	184	297	216	32	142	71	77
<b>FLSD 90 L</b>	184	297	216	32	142	71	77
<b>FLSD 100 L</b>	195	345	216	32	142	71	77
<b>FLSD 112 M</b>	220	346	225	34	142	71	77
<b>FLSD 132 S</b>	264	462	239	56	142	71	77
<b>FLSD 132 M</b>	264	462	239	56	142	71	77

\* Dimensions not including cable gland

IEC symbol	Faceplate dimensions						
	M	N	P	T	n	$\alpha^\circ$	Thread x length
<b>FT 165</b>	165	130	200	3.5	4	45	M10 x 20

# 3-phase TEFV induction motors ATEX GAS - Zones 1 & 2



# TEFV induction motors - Cast iron frame

## FLSE increased safety - FLSN non-sparking

### Electromechanical characteristics



PAGE

## F1 - Selection data - FLSE increased safety - Zone 1

F1.1 - 2 poles - 3000 min <sup>-1</sup> - Ex e II T3 .....	56
F1.2 - 4 poles - 1500 min <sup>-1</sup> - Ex e II T3 .....	57
F1.3 - 6 poles - 1000 min <sup>-1</sup> - Ex e II T3 .....	58
F1.4 - 2 poles - 3000 min <sup>-1</sup> - Ex e II T4 .....	59
F1.5 - 4 poles - 1500 min <sup>-1</sup> - Ex e II T4 .....	60

## F2 - Selection data - FLSN non-sparking - Zone 2

F2.1 - 2 poles - 3000 min <sup>-1</sup> - Ex nA II T3 .....	62
F2.2 - 4 poles - 1500 min <sup>-1</sup> - Ex nA II T3 .....	63
F2.3 - 6 poles - 1000 min <sup>-1</sup> - Ex nA II T3 .....	64
F2.4 - 8 poles - 750 min <sup>-1</sup> - Ex nA II T3 .....	65

## F3 - Dimensions

F3.1 - Shaft extensions .....	66
F3.2 - Foot mounted <b>IM B3 (IM 1001)</b> .....	67
F3.3 - Foot and flange mounted <b>IM B35 (IM 2001)</b> .....	68
F3.4 - Flange mounted <b>IM B5 (IM 3001)</b> .....	69
F3.5 - Foot and face mounted <b>IM B34 (IM 2101)</b> .....	70
F3.6 - Face mounted <b>IM B14 (IM 3601)</b> .....	71

# TEFV induction motors - Cast iron frame

## FLSE increased safety - Zone 1

### Selection data



F1.1 - 2 poles - 3000 min<sup>-1</sup>

**2**  
poles  
3000 min<sup>-1</sup>

Ex e II T3

IP 55  
Cl. F - ΔT 80K  
400 V ± 10%

MAINS SUPPLY Δ 230 / Y 400 V or Δ 400 V **50 Hz**

Type	Rated power	Rated speed	Rated torque	Rated current	Power factor	Efficiency IEC 60034-2; 1996	Starting current/ Rated current	Starting torque/ Rated torque	Maximum torque/ Rated torque	Locked rotor time	Moment of inertia	Weight	Noise
	P <sub>N</sub> kW	N <sub>N</sub> min <sup>-1</sup>	M <sub>N</sub> N.m	I <sub>N(400V)</sub> A	Cos φ	η %	I <sub>d</sub> /I <sub>n</sub>	M <sub>d</sub> /M <sub>n</sub>	M <sub>m</sub> /M <sub>n</sub>	t <sub>ε</sub> s	J kg.m <sup>2</sup>	IM B3 kg	LP db(A)
<b>FLSE 80 L</b>	0.75	2872	2.5	1.6	0.84	79.4	6.8	2.9	3.0	7.6	0.0007	15	61
<b>FLSE 80 L</b>	1.1	2870	3.75	2.3	0.86	78.5	7.9	3.2	3.1	7.5	0.0009	16	61
<b>FLSE 90 L</b>	1.5	2860	5	2.9	0.88	83.6	7.8	3.1	3.1	7	0.0019	25	64
<b>FLSE 90 L</b>	2.2	2884	7.5	4.2	0.87	85.7	8.5	2.4	3.1	6	0.0019	25	64
<b>FLSE 100 LK</b>	3	2900	10.1	5.5	0.91	86.2	7.6	1.8	2.5	8	0.0069	42	66
<b>FLSE 112 MU</b>	4	2928	13.5	7.1	0.92	88.6	9.6	2.0	3.0	7	0.0099	54	69
<b>FLSE 132 SM</b>	5.5	2926	18.6	9.7	0.91	89.8	7.7	1.7	2.6	8.6	0.0263	71	72
<b>FLSE 132 SM</b>	7.5	2929	25.4	13.1	0.92	90.4	8.5	1.7	2.6	8.5	0.031	75	72

# TEFV induction motors - Cast iron frame

## FLSE increased safety - Zone 1

### Selection data



F1.2 - 4 poles - 1500 min<sup>-1</sup>

**4**  
poles  
1500 min<sup>-1</sup>

Ex e II T3

IP 55  
Cl. F - ΔT 80K  
400 V ± 10%

MAINS SUPPLY Δ 230 / Y 400 V or Δ 400 V 50 Hz

Type	Rated power	Rated speed	Rated torque	Rated current	Power factor	Efficiency IEC 60034-2; 1996	Starting current/ Rated current	Starting torque/ Rated torque	Maximum torque/ Rated torque	Locked rotor time	Moment of inertia	Weight	Noise
	P <sub>N</sub> kW	N <sub>N</sub> min <sup>-1</sup>	M <sub>N</sub> N.m	I <sub>N(400V)</sub> A	Cos φ	η %	I <sub>d</sub> /I <sub>n</sub>	M <sub>d</sub> /M <sub>n</sub>	M <sub>m</sub> /M <sub>n</sub>	t <sub>ε</sub> s	J kg.m <sup>2</sup>	IM B3 kg	LP db(A)
<b>FLSE 80 L</b>	0.75	1430	5	2	0.72	74	5.3	2.2	2.3	10	0.0024	17	44
<b>FLSE 90 L</b>	1.1	1440	7.5	2.5	0.83	78.8	6.0	2.2	2.6	8.1	0.0032	22	50
<b>FLSE 90 L</b>	1.5	1450	10	3.7	0.75	78	6.2	1.7	2.0	7.2	0.0037	23	50
<b>FLSE 100 LK</b>	2.2	1460	15	4.4	0.84	85.2	6.0	1.5	1.9	9.5	0.0077	41	52
<b>FLSE 100 LK</b>	3	1457	20	5.9	0.85	86	6.4	1.6	1.9	8	0.0107	44	52
<b>FLSE 112 MU</b>	4	1458	27.2	7.7	0.86	86.9	7.6	2.0	2.1	8.4	0.0137	52	52
<b>FLSE 132 SM</b>	5.5	1464	37.4	10.3	0.87	88.4	7.9	1.8	2.5	9	0.0196	66	59
<b>FLSE 132 M</b>	7.5	1457	50	14.8	0.85	86	7.9	1.9	2.6	5.5	0.023	71	59

# TEFV induction motors - Cast iron frame

## FLSE increased safety - Zone 1

### Selection data



F1.3 - 6 poles - 1000 min<sup>-1</sup>

**6**  
poles  
1000 min<sup>-1</sup>

Ex e II T3

IP 55  
Cl. F - ΔT 80K  
400 V ± 10%

MAINS SUPPLY Δ 230 / Y 400 V or Δ 400 V 50 Hz

Type	Rated power P <sub>N</sub> kW	Rated speed N <sub>N</sub> min <sup>-1</sup>	Rated torque M <sub>N</sub> N.m	Rated current I <sub>N(400V)</sub> A	Power factor Cos φ	Efficiency IEC 60034-2; 1996 η %	Starting current/ Rated current I <sub>d</sub> /I <sub>n</sub>	Starting torque/ Rated torque M <sub>d</sub> /M <sub>n</sub>	Maximum torque/ Rated torque M <sub>m</sub> /M <sub>n</sub>	Locked rotor time t <sub>ε</sub> s	Moment of inertia J kg.m <sup>2</sup>	Weight IM B3 kg	Noise LP db(A)
FLSE 80 L	0.37	948	3.7	1.2	0.68	65.3	3.7	1.6	2.0	12	0.0028	16	40
FLSE 80 L	0.55	955	5.5	1.8	0.64	68.6	4.5	2.1	2.4	8.4	0.0036	18	40
FLSE 90 L	0.75	935	7.5	2.2	0.67	75	4.6	2.6	2.6	10.5	0.0037	23	45
FLSE 90 LU	1.1	915	11.5	2.9	0.79	72.8	5.6	2.8	2.9	9	0.0048	25	45
FLSE 100 LK	1.5	947	15	3.8	0.71	80.4	5.0	2.2	7.0	8.5	0.0136	41	48
FLSE 112 M	2.2	960	22.7	5.3	0.76	81	6.2	2.2	2.7	7.3	0.012	44	48
FLSE 132 SM	3	963	30	7	0.74	84.6	4.3	1.2	1.6	6.9	0.023	68	55
FLSE 132 M	4	966	40	9.1	0.74	85.9	4.6	1.3	1.6	7.1	0.0275	72	55
FLSE 132 MU	5.5	963	55	12.3	0.75	86.4	4.7	1.4	1.6	7.1	0.0343	78	55

# TEFV induction motors - Cast iron frame

## FLSE increased safety - Zone 1

### Selection data



F1.4 - 2 poles - 3000 min<sup>-1</sup>

**2**  
poles  
3000 min<sup>-1</sup>

Ex e II T4

IP 55  
Cl. F - ΔT 80K  
400 V ± 10%

MAINS SUPPLY Δ 230 / Y 400 V or Δ 400 V 50 Hz

Type	Rated power	Rated speed	Rated torque	Rated current	Power factor	Efficiency IEC 60034-2; 1996	Starting current/ Rated current	Starting torque/ Rated torque	Maximum torque/ Rated torque	Locked rotor time	Moment of inertia	Weight	Noise
	P <sub>N</sub> kW	N <sub>N</sub> min <sup>-1</sup>	M <sub>N</sub> N.m	I <sub>N(400V)</sub> A	Cos φ	η %	I <sub>d</sub> /I <sub>n</sub>	M <sub>d</sub> /M <sub>n</sub>	M <sub>m</sub> /M <sub>n</sub>	t <sub>E</sub> s	J kg.m <sup>2</sup>	IM B3 kg	LP db(A)
<b>FLSE 80 L</b>	0.75	2879	2.5	1.5	0.84	83.2	7.3	2.5	3.0	5	0.0007	15	61
<b>FLSE 90 L</b>	1.1	2865	3.7	2.1	0.91	83.9	7.6	2.1	2.7	5	0.0019	25	64
<b>FLSE 90 L</b>	1.5	-	-	-	-	-	8.6	2.3	2.3	5	0.0021	25	64
<b>FLSE 100 LK</b>	2.2	2919	7.5	4	0.91	87.2	8.8	2.5	3.2	5	0.0069	42	66
<b>FLSE 112 MU</b>	3	2924	10.1	5.3	0.94	86.7	9.1	2.7	3.4	5	0.0099	54	69
<b>FLSE 132 SM</b>	4	2944	13.5	7.5	0.87	88.4	9.7	2.1	3.2	5	0.0263	71	72
<b>FLSE 132 SM</b>	5.5	2953	18.6	9.7	0.92	89.5	8.9	1.7	2.7	5	0.031	75	72

- Please consult Leroy-Somer

# TEFV induction motors - Cast iron frame

## FLSE increased safety - Zone 1

### Selection data



F1.5 - 4 poles - 1500 min<sup>-1</sup>

**4**  
poles  
1500 min<sup>-1</sup>

Ex e II T4

IP 55  
Cl. F - ΔT 80K  
400 V ± 10%

MAINS SUPPLY Δ 230 / Y 400 V or Δ 400 V 50 Hz

	Rated power	Rated speed	Rated torque	Rated current	Power factor	Efficiency IEC 60034-2; 1996	Starting current/ Rated current	Starting torque/ Rated torque	Maximum torque/ Rated torque	Locked rotor time	Moment of inertia	Weight	Noise
Type	P <sub>N</sub> kW	N <sub>N</sub> min <sup>-1</sup>	M <sub>N</sub> N.m	I <sub>N(400V)</sub> A	Cos φ	η %	I <sub>d</sub> /I <sub>n</sub>	M <sub>d</sub> /M <sub>n</sub>	M <sub>m</sub> /M <sub>n</sub>	t <sub>E</sub> s	J kg.m <sup>2</sup>	IM B3 kg	LP db(A)
<b>FLSE 80 L</b>	0.55	1425	3.75	1.4	0.76	75	5.2	1.9	2.2	9	0.0024	17	44
<b>FLSE 90 L</b>	0.75	1450	5	1.7	0.81	80.5	6.5	2.0	2.7	6	0.0032	22	50
<b>FLSE 90 L</b>	1.1	1447	7.5	2.5	0.78	82.1	6.7	1.8	2.3	5.5	0.0037	23	50
<b>FLSE 100 LK</b>	1.5	1466	10	3.1	0.82	85.5	6.6	1.6	2.1	6	0.0077	41	52
<b>FLSE 100 LK</b>	2.2	1466	15	4.4	0.84	87.3	7.3	1.8	2.2	5	0.0107	44	52
<b>FLSE 112 MU</b>	3	1464	20	5.9	0.85	87.8	7.6	2.0	2.2	5	0.0137	52	52
<b>FLSE 132 SM</b>	4	1465	27.5	7.4	0.89	88	7.7	1.8	2.6	5	0.0154	65	59
<b>FLSE 132 SM</b>	5.5	1466	37.5	10.4	0.87	89.1	8.1	2.0	2.7	5	0.0196	68	59
<b>FLSE 132 MU</b>	7.5	1461	50	13.8	0.88	89.2	7.4	1.6	2.3	5	0.0256	79	62

**TEFV induction motors - Cast iron frame**  
**FLSE increased safety - Zone 1**  
**Selection data**



# TEFV induction motors - Cast iron frame

## FLSN non-sparking - Zone 2

### Selection data



## F2.1 - 2 poles - 3000 min<sup>-1</sup>

**2**  
poles  
3000 min<sup>-1</sup>

Ex nA II T3

IP 55  
Cl. F - ΔT 80K  
400 V ± 10%

### MAINS SUPPLY Δ 230 / Y 400 V or Δ 400 V 50 Hz

Type	Rated power	Rated speed	Rated torque	Rated current	Power factor			Efficiency IEC 60034-2; 1996			Starting current/ Rated current	Starting torque/ Rated torque	Maximum torque/ Rated torque	Moment of inertia	Weight	Noise
	P <sub>N</sub> kW	N <sub>N</sub> min <sup>-1</sup>	M <sub>N</sub> N.m	I <sub>N(400V)</sub> A	Cos φ			η			Id/In	Md/Mn	M <sub>m</sub> /Mn	J kg.m <sup>2</sup>	IM B3 kg	LP db(A)
FLSN 80 L	0.75	2840	2.5	1.6	0.86	0.84	0.76	75.4	75.4	72.3	5.9	2.4	2.2	0.0007	15	61
FLSN 80 L	1.1	2837	3.7	2.4	0.84	0.77	0.65	78.3	78.1	76.1	5.6	2.7	2.4	0.0009	16	61
FLSN 90 S	1.5	2870	5.0	3.3	0.81	0.75	0.64	80.8	79.8	75.7	7.3	3.0	3.1	0.0014	22	64
FLSN 90 L	2.2	2862	7.3	4.3	0.88	0.82	0.71	83.3	83.9	82.3	8.1	3.8	3.6	0.0019	25	64
FLSN 100 L	3	2925	9.8	5.5	0.91	0.89	0.85	82.6	82.3	79.5	8.4	2.5	3.1	0.0022	30	66
FLSN 112 M	4	2940	13.0	7.5	0.89	0.87	0.81	84.3	84.0	81.6	8.7	3.0	3.5	0.0065	40	69
FLSN 132 S	5.5	2940	17.9	10.6	0.86	0.84	0.79	86.3	86.7	85.3	7.6	2.4	3.0	0.0117	61	72
FLSN 132 S	7.5	2950	24.3	14.1	0.87	0.85	0.81	87.2	87.7	86.6	8.9	2.7	3.5	0.0142	66	72
FLSN 160 MA	11	2948	35.8	20	0.90	0.88	0.82	88.9	88.8	87.2	8.4	2.8	2.4	0.037	97	74
FLSN 160 MB	15	2940	48.8	27	0.90	0.88	0.82	90.1	90.0	88.4	8.1	2.8	2.3	0.043	108	74
FLSN 160 L	18.5	2939	60.1	33	0.90	0.88	0.82	90.8	90.6	89.0	7.7	2.6	2.2	0.057	126	74
FLSN 180 MR	22	2941	71.5	40	0.87	0.87	0.80	90.5	90.3	88.4	8.6	3.5	2.6	0.065	135	75
FLSN 200 LA	30	2950	97.1	52	0.90	0.91	0.89	91.5	91.4	90.0	7.7	2.5	2.0	0.13	245	75
FLSN 200 LB	37	2954	119	63.3	0.90	0.89	0.84	93	92.9	91.9	8.0	2.9	2.3	0.16	265	75
FLSN 225 MT	45	2950	145	77.1	0.90	0.89	0.85	93.6	93.5	92.6	7.8	2.7	2.2	0.19	290	76
FLSN 250 M	55	2966	177	95	0.89	0.87	0.81	93.7	93.7	92.8	7.9	2.5	2.3	0.44	405	77
FLSN 280 S	75	2961	245	127.5	0.90	0.89	0.81	94.2	93.7	92.2	8.3	2.6	3.0	0.47	505	77
FLSN 280 M	90	2961	290	147.3	0.92	0.91	0.88	94.9	95	94.4	7.7	2.6	2.4	0.53	560	77
FLSN 315 ST	110	2974	353	178.5	0.93	0.91	0.86	95.5	95.3	94.5	8.7	2.8	3.0	1.08	850	77
FLSN 315 M	132	2962	426	221	0.90	0.89	0.87	95.4	95.4	94.7	6.9	1.8	2.1	1.71	1000	84
FLSN 315 LA	160	2969	515	272	0.89	0.87	0.85	95.4	94.9	92.8	7.4	2.0	2.3	1.71	1050	84
FLSN 315 LB	200	2967	644	342	0.88	0.86	0.80	95.3	95.1	93.8	7.9	2.3	2.2	1.99	1150	84
FLSN 355 LA	250	2978	802	421	0.89	0.87	0.85	95.2	94.9	94	7.3	2.1	2.3	3.39	1400	84
FLSN 355 LB	275	2980	881	466	0.89	0.90	0.86	95.8	95.6	94.6	8.3	2.3	2.9	3.39	1500	84
FLSN 355 LB •	315	2976	1011	529	0.90	0.89	0.89	95	94.7	94.7	7.1	1.8	2.1	3.39	1500	84
FLSN 355 LC	330	2980	1058	562	0.88	0.86	0.81	96.3	96	95.1	7.9	1.9	2.6	3.39	1915	84
FLSN 355 LC	355	2979	1138	593	0.90	0.88	0.83	95.4	95.1	95.1	8.4	2.3	2.4	4.03	1915	84
FLSN 355 LD •	400	2977	1283	669	0.89	0.87	0.82	95.9	95.6	95.6	7.3	2.0	2.1	4.03	1915	84

• Class F temperature rise  
For power ratings above 400 kW, please consult Leroy-Somer.

# TEFV induction motors - Cast iron frame

## FLSN non-sparking - Zone 2

### Selection data



F2.2 - 4 poles - 1500 min<sup>-1</sup>

**4**  
poles  
1500 min<sup>-1</sup>

Ex nA II T3

IP 55  
Cl. F - ΔT 80K  
400 V ± 10%

MAINS SUPPLY Δ 230 / Y 400 V or Δ 400 V 50 Hz

Type	Rated power	Rated speed	Rated torque	Rated current	Power factor			Efficiency IEC 60034-2; 1996			Starting current/ Rated current	Starting torque/ Rated torque	Maximum torque/ Rated torque	Moment of inertia	Weight	Noise
	P <sub>N</sub> kW	N <sub>N</sub> min <sup>-1</sup>	M <sub>N</sub> N.m	I <sub>N(400V)</sub> A	Cos φ			η			Id/In	Md/Mn	M <sub>m</sub> /Mn	J kg.m <sup>2</sup>	IM B3 kg	LP db(A)
FLSN 80 L	0.55	1410	3.7	1.6	0.74	0.69	0.56	69.2	69.4	65.0	4.4	2.1	2.3	0.0013	15	44
FLSN 80 L	0.75	1425	5.0	2	0.75	0.70	0.58	75.4	73.9	68.8	5.7	3.0	2.8	0.0016	16	44
FLSN 90 S	1.1	1429	7.4	2.5	0.83	0.77	0.68	76.9	78.5	76.7	4.9	1.6	2.0	0.0026	21	50
FLSN 90 L	1.5	1428	10.0	3.3	0.82	0.74	0.62	79.1	79.5	77.0	5.3	1.8	2.3	0.0032	22	50
FLSN 90 L	1.8	1438	12.0	4	0.82	0.75	0.63	79.6	79.9	77.3	5.9	2.2	3.3	0.0037	24	50
FLSN 100 L	2.2	1457	14.4	4.6	0.83	0.78	0.67	80.4	81.0	79.0	6.3	2.0	2.5	0.0043	30	52
FLSN 100 L	3	1454	19.7	6.2	0.82	0.76	0.64	82.7	83.1	81.3	6.5	2.1	2.6	0.0055	33	52
FLSN 112 M	4	1462	26.1	8.4	0.81	0.74	0.62	85.1	84.9	82.8	7.4	2.6	3.1	0.012	45	52
FLSN 132 S	5.5	1467	35.8	10.9	0.84	0.78	0.66	86.9	86.8	85.1	8.0	2.8	3.8	0.0196	66	59
FLSN 132 M	7.5	1450	49.4	14.3	0.87	0.82	0.75	86.7	87.3	86.3	7.3	1.9	2.9	0.023	71	59
FLSN 132 M	9	1449	59.3	16.8	0.88	0.80	0.72	87.9	88.6	87.9	7.6	2.9	3.0	0.025	74	59
FLSN 160 M	11	1464	72.2	21.4	0.83	0.79	0.68	88.9	88.9	87.3	7.8	2.6	3.3	0.06	103	65
FLSN 160 L	15	1467	98.4	29.6	0.82	0.75	0.64	89.5	89.3	87.5	7.9	2.6	3.2	0.079	120	65
FLSN 180 MR	18.5	1461	121	35.5	0.83	0.78	0.67	90.6	90.9	89.7	8.8	3.3	2.7	0.095	135	64
FLSN 180 L	22	1466	143	41	0.86	0.82	0.72	91.8	92.0	91.1	7.0	3.0	3.0	0.137	184	64
FLSN 200 L	30	1471	195	55	0.85	0.80	0.70	91.8	91.1	89.7	6.5	2.8	2.3	0.24	260	66
FLSN 225 ST	37	1476	239	69.5	0.82	0.76	0.64	93	93.3	92.8	7.1	3.2	3.3	0.28	290	66
FLSN 225 M	45	1483	290	78.6	0.87	0.83	0.74	93.8	93.8	93.2	7.0	2.6	2.9	0.7	388	68
FLSN 250 M	55	1479	355	102	0.82	0.80	0.71	94	93.8	93.4	6.6	2.4	2.0	0.7	395	68
FLSN 280 S	75	1483	482.9	142.4	0.82	0.79	0.66	94.4	94.5	93.8	7.7	3.0	3.0	0.815	475	68
FLSN 280 M	90	1478	581.5	163.6	0.85	0.81	0.72	94.2	93.7	93.1	7.4	2.9	2.5	1.015	565	68
FLSN 315 ST	110	1482	708.8	205.0	0.83	0.79	0.71	94.3	96.3	96.5	7.3	2.9	2.7	1.83	850	70
FLSN 315 M	132	1489	846.5	250.2	0.81	0.75	0.65	93.8	93.1	91.6	8.5	3.2	2.7	2.91	1000	73
FLSN 315 LA	160	1489	1026.1	300.8	0.81	0.76	0.64	95.1	94.9	93.9	8.3	2.5	3.2	3.4	1050	73
FLSN 315 LB •	200	1486	1285.2	379.8	0.80	0.74	0.66	95.2	95	94.5	8.2	2.3	3.5	3.4	1150	73
FLSN 355 LA •	250	1490	1602.2	436.2	0.88	0.85	0.78	95.4	95.1	94.1	8.2	1.9	3.2	6.2	1510	80
FLSN 355 LB •	300	1490	1922.7	519.1	0.88	0.87	0.81	95.5	95.3	94.6	7.4	1.8	2.9	6.2	1550	80
FLSN 355 LC	315	1491	2017.5	593.4	0.81	0.75	0.63	95	94.5	93.1	9.7	2.2	3.7	6.5	1800	80
FLSN 355 LC •	355	1491	2273.6	661.9	0.82	0.76	0.65	94.7	94.2	92.7	8.9	2.0	3.3	6.5	1800	80
FLSN 355 LD •	400	1491	2561.9	705.9	0.86	0.84	0.77	96	95.7	95	7.0	2.1	2.3	7.4	1930	80

• Class F temperature rise  
For power ratings above 400 kW, please consult Leroy-Somer.

# TEFV induction motors - Cast iron frame

## FLSN non-sparking - Zone 2

### Selection data



## F2.3 - 6 poles - 1000 min<sup>-1</sup>

**6**  
poles  
1000 min<sup>-1</sup>

Ex nA II T3

IP 55  
Cl. F - ΔT 80K  
400 V ± 10%

### MAINS SUPPLY Δ 230 / Y 400 V or Δ 400 V 50 Hz

Type	Rated power	Rated speed	Rated torque	Rated current	Power factor			Efficiency IEC 60034-2; 1996			Starting current/ Rated current	Starting torque/ Rated torque	Maximum torque/ Rated torque	Moment of inertia	Weight	Noise
	P <sub>N</sub> kW	N <sub>N</sub> min <sup>-1</sup>	M <sub>N</sub> N.m	I <sub>N(400V)</sub> A	Cos φ			η			Id/In	Md/Mn	M <sub>m</sub> /Mn	J kg.m <sup>2</sup>	IM B3 kg	LP db(A)
FLSN 80 L	0.25	950	2.5	0.8	0.74	0.68	0.55	60.3	58.0	54.0	3.6	2.0	1.9	0.0022	14	40
FLSN 80 L	0.37	940	3.8	1.2	0.74	0.68	0.55	61.0	59.0	55.0	3.8	1.9	2.1	0.0028	16	40
FLSN 80 L	0.55	955	5.5	1.8	0.67	0.59	0.46	65.0	64.0	60.0	4.4	2.5	2.6	0.0036	18	40
FLSN 90 S	0.75	940	7.6	2.1	0.80	0.75	0.65	70.4	69.1	63.1	3.5	2.0	2.2	0.0031	22	45
FLSN 90 L	1.1	940	11.2	2.7	0.81	0.76	0.66	70.2	69.9	65.1	4.8	1.8	2.2	0.0037	23	45
FLSN 100 L	1.5	955	15.0	3.5	0.78	0.72	0.61	77.9	78.0	76.0	6.3	2.2	2.8	0.0056	30	48
FLSN 112 M	2.2	960	21.9	5.2	0.77	0.71	0.59	79.7	79.6	76.9	5.5	2.3	2.4	0.012	44	48
FLSN 132 S	3	953	30.1	6.9	0.76	0.74	0.63	81.9	82.2	80.0	5.3	2.2	2.4	0.0199	61	55
FLSN 132 M	4	970	39.4	9	0.78	0.72	0.61	84.0	83.9	81.5	6.7	2.8	2.7	0.0275	72	55
FLSN 132 MU	5.5	970	54.1	12.2	0.79	0.74	0.63	83.5	83.5	81.1	7.1	3.2	2.7	0.0343	78	55
FLSN 160 M	7.5	968	74.0	16	0.79	0.72	0.59	85.0	84.6	82.0	4.3	1.5	2.3	0.085	100	56
FLSN 160 L	11	966	109	23	0.80	0.74	0.63	85.4	85.4	83.4	5.0	1.5	2.3	0.12	128	56
FLSN 180 L	15	975	147	30	0.81	0.78	0.69	88.5	88.7	87.8	6.8	2.1	3.1	0.2	170	63
FLSN 200 LA	18.5	975	181	36	0.83	0.77	0.68	90.1	90.2	89.0	7.0	2.2	2.4	0.29	240	65
FLSN 200 LB	22	973	216	44	0.81	0.74	0.65	90.7	89.6	88.3	6.7	2.5	1.7	0.31	260	65
FLSN 225 M	30	984	293	59	0.80	0.74	0.62	92.9	92.9	91.7	7.2	2.5	2.6	0.94	392	66
FLSN 250 M	37	983	362	73	0.79	0.74	0.62	92.7	92.8	91.6	7.0	2.4	2.5	0.94	394	66
FLSN 280 S	45	979	438.9	87.4	0.81	0.76	0.67	92.4	92.8	92.1	6.2	2.3	2.1	1.13	455	66
FLSN 280 M	55	983	534.3	106.0	0.81	0.75	0.64	93.1	93.0	92.1	7.3	2.5	2.6	1.26	532	66
FLSN 315 ST	75	987	725.6	135.9	0.86	0.85	0.79	94.5	94.7	94.2	6.3	2.4	2.3	1.8	850	76
FLSN 315 M	90	987	870.8	165.4	0.85	0.80	0.73	95.1	95.0	94.6	6.6	1.8	2.7	2.6	1000	76
FLSN 315 LA	110	983	1068.6	200.2	0.85	0.83	0.73	94.0	94.2	93.4	5.9	1.6	2.5	2.6	1050	76
FLSN 315 LB	132	988	1275.8	244.5	0.83	0.77	0.67	95.4	95.3	94.6	7.3	2.0	3.4	3.5	1125	76
FLSN 315 LB	150	992	1443.9	295.3	0.78	0.73	0.60	95.2	94.9	93.7	7.8	1.8	3.0	3.5	1125	76
FLSN 355 LA	185	987	1789.9	349.2	0.81	0.77	0.65	95.6	95.5	94.9	7.2	2.0	3.6	5.4	1415	78
FLSN 355 LB	220	988	2126.4	417.1	0.81	0.76	0.66	95.1	94.8	93.8	7.2	2.0	2.6	6.3	1535	78
FLSN 355 LD	250	993	2404.2	465.7	0.82	0.79	0.72	96.1	96.0	95.3	7.2	1.8	2.3	8.6	1935	78
FLSN 355 LD	300	992	2887.9	558.8	0.82	0.79	0.71	95.7	95.6	94.7	6.1	1.6	2.1	8.6	1935	78

For power ratings above 300 kW, please consult Leroy-Somer.

# TEFV induction motors - Cast iron frame

## FLSN non-sparking - Zone 2

### Selection data



F2.4 - 8 poles - 750 min<sup>-1</sup>

**8**  
poles  
750 min<sup>-1</sup>

Ex nA II T3

IP 55  
Cl. F - ΔT 80K  
400 V ± 10%

MAINS SUPPLY Δ 230 / Y 400 V or Δ 400 V 50 Hz

Type	Rated power	Rated speed	Rated torque	Rated current	Power factor			Efficiency IEC 60034-2; 1996			Starting current/ Rated current	Starting torque/ Rated torque	Maximum torque/ Rated torque	Moment of inertia	Weight	Noise
	P <sub>N</sub> kW	N <sub>N</sub> min <sup>-1</sup>	M <sub>N</sub> N.m	I <sub>N(400V)</sub> A	Cos φ			η			Id/In	Md/Mn	M <sub>m</sub> /Mn	J kg.m <sup>2</sup>	IM B3 kg	LP db(A)
FLSN 80 L	0.18	710	2.42	0.8	0.64	0.58	0.46	52.3	51	45	3.0	1.7	1.7	0.0028	15.5	40
FLSN 80 L	0.25	720	3.32	1.1	0.6	0.55	0.44	54.5	54	46	3.2	2.0	2.4	0.0036	17	40
FLSN 90 S	0.37	685	5.16	1.2	0.71	0.57	0.45	64	63	59	3.5	1.6	1.6	0.00314	22	45
FLSN 90 L	0.55	695	7.56	1.7	0.72	0.59	0.46	63	58	54	3.3	1.8	1.8	0.0037	23	45
FLSN 100 LK	0.75	720	9.95	2.3	0.68	0.6	0.47	70.9	70	66	4.1	1.9	1.9	0.0085	41	48
FLSN 100 LK	1.1	720	14.6	3.8	0.62	0.56	0.44	68	66	60	4.1	1.8	2.4	0.0117	43	48
FLSN 112 M	1.5	725	19.8	4.8	0.63	0.57	0.45	72.5	72	68	4.0	2.1	2.2	0.015	45	49
FLSN 132 S	2.2	715	29.4	7.2	0.6	0.55	0.44	74	74	72	3.2	1.4	1.8	0.0253	71	54
FLSN 132 M	3	705	40.6	9.1	0.63	0.57	0.46	76	76	73	3.1	1.3	1.9	0.0334	81	54
FLSN 160 MA	4	710	53.8	11.3	0.63	0.56	0.44	81.5	82	80.1	3.8	1.4	1.7	0.062	105	56
FLSN 160 MB	5.5	710	74	15	0.65	0.58	0.46	82	82.5	80.6	3.8	1.4	1.7	0.071	111	56
FLSN 160 L	7.5	715	100	20	0.65	0.58	0.46	83	93.5	81.6	3.8	1.5	1.8	0.086	128	56
FLSN 180 L	11	724	145	27	0.7	0.63	0.51	85.1	84.9	82.4	3.9	1.4	1.7	0.21	175	62
FLSN 200 L	15	729	197	34	0.72	0.66	0.53	88.1	88	86.2	5.0	1.8	2.6	0.32	265	62
FLSN 225 ST	18.5	727	243	41	0.73	0.67	0.54	89	88.9	87.1	5.0	1.6	2.3	0.38	285	65
FLSN 225 M	22	732	287	48	0.72	0.68	0.58	92.1	92.6	91.7	5.9	1.8	2.5	0.83	388	65
FLSN 250 M	30	729	393	61	0.78	0.74	0.64	91.2	91.7	90.8	6.2	1.8	2.5	0.83	393	65
FLSN 280 S	37	723	489	75	0.78	0.74	0.64	92	92.1	91	4.5	1.3	1.8	1.4	472	65
FLSN 280 M	45	730	589	102	0.7	0.66	0.55	91.7	91.8	90.7	6.0	2.3	3.2	1.75	563	65
FLSN 315 ST	55	738	712	102	0.83	0.8	0.71	94.2	94.5	94	7.4	2.1	3.0	2.7	850	75
FLSN 315 M	75	743	964	147	0.78	0.76	0.68	94.8	95	94.3	7.4	2.0	2.2	3.1	1000	78
FLSN 315 LA	90	742	1158	177	0.78	0.76	0.68	94.7	94.9	94.2	6.7	1.9	2.1	4.2	1030	78
FLSN 315 LB	110	742	1416	222	0.76	0.74	0.66	94.8	95	94.3	7.2	2.0	2.2	5.1	1125	78
FLSN 355 LA	132	741	1701	258	0.78	0.75	0.68	95.3	95.2	94.2	6.7	2.0	2.2	5.5	1415	78
FLSN 355 LB	160	741	2062	312	0.78	0.75	0.68	95.3	95.2	94.2	6.9	2.0	2.2	6	1535	78
FLSN 355 LD	200	741	2577	364	0.84	0.81	0.74	95	94.9	93.9	6.7	1.6	1.7	6.5	1935	78

For power ratings above 200 kW, please consult Leroy-Somer.

# TEFV induction motors - Cast iron frame

## FLSE increased safety - FLSN non-sparking

### Dimensions



## F3.1 - Shaft extensions

Dimensions in millimetres

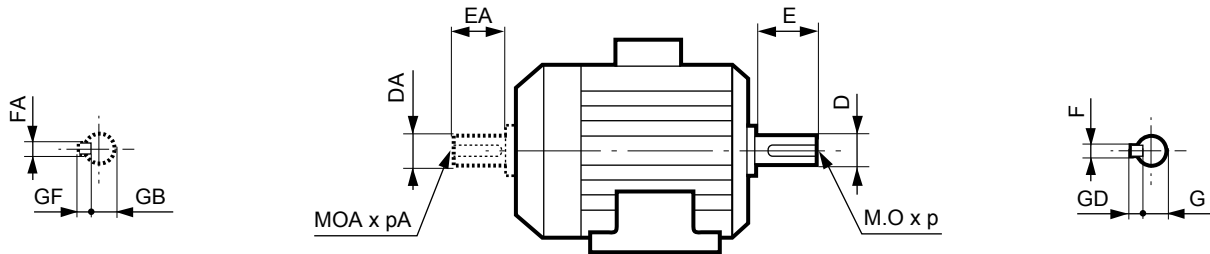

Type	Main shaft extension																	
	4, 6 and 8 poles									2 poles								
	F	GD	D	G	E	O	p	L	LO	F	GD	D	G	E	O	p	L	LO
FLSE/FLSN 80 L	6	6	19j6	15.5	40	6	16	30	6	6	6	19j6	15.5	40	6	16	30	6
FLSE/FLSN 90 S/L/LU	8	7	24j6	20	50	8	19	40	6	8	7	24j6	20	50	8	19	40	6
FLSE/FLSN 100 L/LK	8	7	28j6	24	60	10	22	50	6	8	7	28j6	24	60	10	22	50	6
FLSE/FLSN 112 M/MU	8	7	28j6	24	60	10	22	50	6	8	7	28j6	24	60	10	22	50	6
FLSE/FLSN 132 S/SM/M/MR/MU	10	8	38k6	33	80	12	28	63	10	10	8	38k6	33	80	12	28	63	10
FLSN 160 M/L	12	8	42k6	37	110	16	36	90	20	12	8	42k6	37	110	16	36	90	20
FLSN 180 MR/L	14	9	48k6	42.5	110	16	36	90	20	14	9	48k6	42.5	110	16	36	90	20
FLSN 200 L	16	10	55m6	49	110	20	42	90	20	16	10	55m6	49	110	20	42	90	20
FLSN 225 ST/MT/M	18	11	60m6	53	140	20	42	125	15	16	10	55m6	49	110	20	42	90	20
FLSN 250 M	18	11	65m6	58	140	20	42	125	15	18	11	60m6	53	140	20	42	125	15
FLSN 280 S/M	20	12	75m6	67.5	140	20	42	125	15	18	11	65m6	58	140	20	42	125	15
FLSN 315 ST/M	22	14	80m6	71	170	20	42	140	30	18	11	65m6	58	140	20	42	125	15
FLSN 315 L	25	14	90m6	81	170	24	50	140	30	20	12	70m6	62.5	140	20	42	125	15
FLSN 355 L	28	16	100m6	90	210	24	50	180	30	22	14	80m6	71	170	20	42	140	30

Type	Secondary shaft extension																	
	4, 6 and 8 poles									2 poles								
	FA	GF	DA	GB	EA	OA	pA	L'	LO'	FA	GF	DA	GB	EA	OA	pA	L'	LO'
FLSE/FLSN 80 L	5	5	14j6	11	30	5	15	25	3.5	5	5	14j6	11	30	5	15	25	3.5
FLSE/FLSN 90 S/L/LU	6	6	19j6	15.5	40	6	16	30	6	6	6	19j6	15.5	40	6	16	30	6
FLSE/FLSN 100 L/LK	8	7	24j6	20	50	8	19	40	6	8	7	24j6	20	50	8	19	40	6
FLSE/FLSN 112 M/MU	8	7	24j6	20	50	8	19	40	6	8	7	24j6	20	50	8	19	40	6
FLSE/FLSN 132 S/SM/M/MR/MU	8	7	28k6	24	60	10	22	50	6	8	7	28j6	24	60	10	22	50	6
FLSN 160 M/L	12	8	42k6	37	110	16	36	90	20	12	8	42k6	37	110	16	36	90	20
FLSN 180 MR/L	14	9	48k6	42.5	110	16	36	90	20	14	9	48k6	42.5	110	16	36	90	20
FLSN 200 L	16	10	55m6	49	110	20	42	90	20	16	10	55m6	49	110	20	42	90	20
FLSN 225 ST/MT/M	18	11	60m6	53	140	20	42	125	15	16	10	55m6	49	110	20	42	90	20
FLSN 250 M	18	11	60m6	53	140	20	42	125	15	18	11	60m6	53	140	20	42	125	15
FLSN 280 S/M	20	12	60m6	53	140	20	42	125	15	18	11	60m6	53	140	20	42	125	15
FLSN 315 ST/M	22	14	80m6	71	170	20	42	140	30	18	11	65m6	58	140	20	42	125	15
FLSN 315 L	25	14	90m6	81	170	24	50	140	30	20	12	70m6	62.5	140	20	42	125	15
FLSN 355 L	28	16	100m6	90	210	24	50	180	30	22	14	80m6	71	170	20	42	140	30

# TEFV induction motors - Cast iron frame

## FLSE increased safety - FLSN non-sparking

### Dimensions



## F3.2 - Foot mounted IM B3 (IM 1001)

Dimensions in millimetres

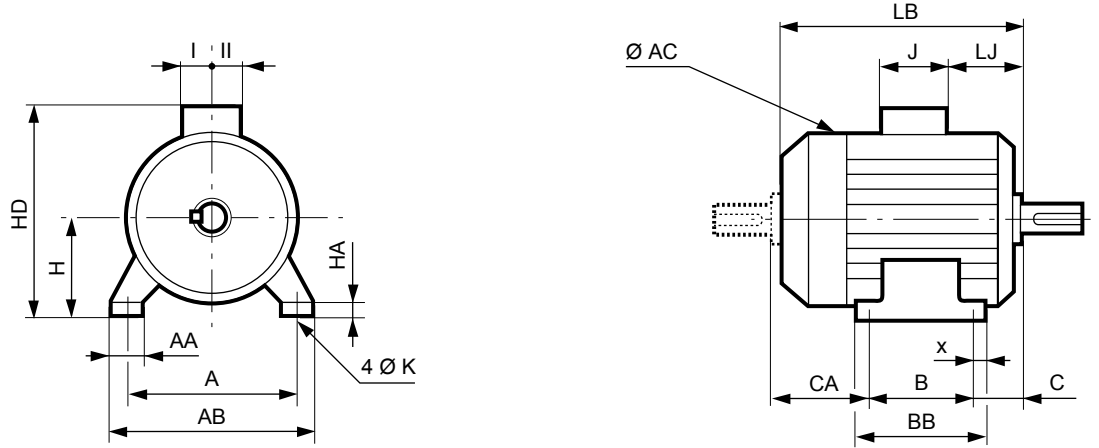

Type	Main dimensions																	
	A	AB	B	BB	C	X	AA	K	HA	H	AC	HD	LB	LJ	J	I	II*	CA
FLSE/FLSN 80 L	125	157	100	130	50	20	32	9	11	80	170	231	216	7	136	68	68	83
FLSE/FLSN 90 S	140	170	100	162	37	27	26	9	10	90	185	251	251	9	136	68	68	126
FLSE/FLSN 90 L	140	170	125	162	52	27	26	9	10	90	185	251	251	9	136	68	68	110
FLSE 90 LU	140	172	125	160	52	27	26	9	11	90	185	251	271	9	136	68	68	130
FLSE/FLSN 100 L	160	196	140	185	63	29	40	12	12	100	204	258	300	8	136	68	68	-
FLSE/FLSN 100 LK	160	200	140	174	63	22	42	12	12	100	226	288	323	55	114	57	57	119
FLSE/FLSN 112 M	190	230	140	185	70	32	48	12	12	112	231	294	309	18	136	68	68	-
FLSE/FLSN 112 MU	190	230	140	185	70	32	48	12	12	112	231	294	328	18	136	68	68	-
FLSE/FLSN 132 S	216	255	140	240	89	50	63	12	16	132	264	347	385	22	136	68	68	170
FLSE/FLSN 132 M	216	255	178	240	89	50	63	12	16	132	264	347	385	22	136	68	68	170
FLSE/FLSN 132 MU	216	255	178	240	89	50	63	12	16	132	264	347	412	22	136	68	68	170
FLSN 160 M	254	294	210	294	108	20	65	14	20	160	310	440	495	30	246	126	147	182
FLSN 160 L	254	294	254	294	108	20	65	14	20	160	310	440	495	30	246	126	147	138
FLSN 180 MR	279	324	241	295	121	25	80	14	25	180	310	460	515	30	246	126	147	158
FLSN 180 L	279	330	279	335	121	28	70	14	28	180	350	481	555	42	246	126	147	160
FLSN 200 L	318	374	305	361	133	28	80	18	44	200	394	530	681	51	246	126	147	248
FLSN 225 ST	356	420	286	367	149	28	100	18	35	225	394	555	681	51	246	126	147	251
FLSN 225 MT	356	420	311	367	149	28	100	18	35	225	394	555	681	51	246	126	147	226
FLSN 225 M	356	426	311	375	149	32	80	18	27	225	540	656	780	70	352	173	210	326
FLSN 250 M	406	476	349	413	168	32	80	22	27	250	540	681	780	70	352	173	210	269
FLSN 280 S	457	527	368	432	190	32	80	22	27	280	540	711	860	70	352	173	210	302
FLSN 280 M	457	527	419	483	190	32	80	22	27	280	540	711	960	70	352	173	210	357
FLSN 315 ST	508	598	406	547	216	45	90	27	45	315	556	761	1068	68	352	173	210	452
FLSN 315 M	508	600	457	598	216	45	100	27	45	315	624	835	1203	70	452	217	269	536
FLSN 315 L	508	600	508	598	216	45	100	27	45	315	632	835	1203	70	452	217	269	485
FLSN 355 LA/LB	610	710	630	710	254	40	110	27	35	355	700	910	1305	61	452	217	269	427
FLSN 355 LC/LD	610	710	630	710	254	40	110	27	35	355	700	910	1430	61	452	217	269	552

\* Dimensions not including cable gland

# TEFV induction motors - Cast iron frame

## FLSE increased safety - FLSN non-sparking

### Dimensions



## F3.3 - Foot and flange mounted IM B35 (IM 2001)

Dimensions in millimetres

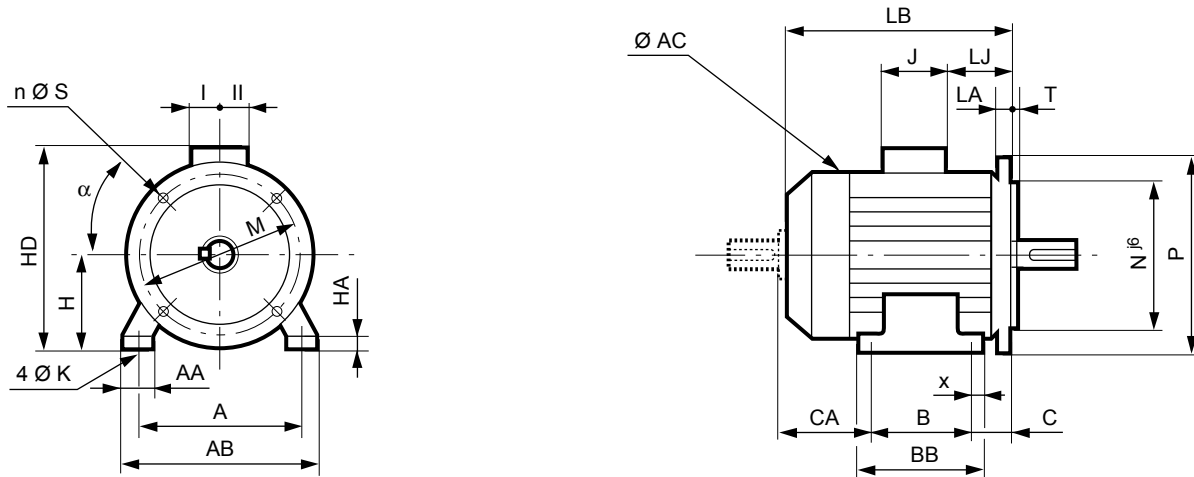

Type	Main dimensions																		
	A	AB	B	BB	C	X	AA	K	HA	H	AC	HD	LB	LJ	J	I	II*	CA	Symbol
FLSE/FLSN 80 L	125	157	100	130	50	20	32	9	11	80	170	231	216	7	136	68	68	83	FF165
FLSE/FLSN 90 S	140	170	100	162	37	27	26	9	10	90	185	251	251	9	136	68	68	126	FF165
FLSE/FLSN 90 L	140	170	125	162	52	27	26	9	10	90	185	251	251	9	136	68	68	110	FF165
FLSE 90 LU	140	172	125	160	52	27	26	9	11	90	185	251	271	9	136	68	68	130	FF165
FLSE/FLSN 100 L	160	196	140	185	63	29	40	12	12	100	204	258	300	8	136	68	68	-	FF215
FLSE/FLSN 100 LK	160	200	140	174	63	22	42	12	12	100	226	288	323	55	114	57	57	119	FF215
FLSE/FLSN 112 M	190	230	140	185	70	32	48	12	12	112	231	294	309	18	136	68	68	-	FF215
FLSE/FLSN 112 MU	190	230	140	185	70	32	48	12	12	112	231	294	328	18	136	68	68	-	FF215
FLSE/FLSN 132 S	216	255	140	240	89	50	63	12	16	132	264	347	385	22	136	68	68	170	FF265
FLSE/FLSN 132 M	216	255	178	240	89	50	63	12	16	132	264	347	385	22	136	68	68	170	FF265
FLSE/FLSN 132 MU	216	255	178	240	89	50	63	12	16	132	264	347	412	22	136	68	68	170	FF265
FLSN 160 M	254	294	210	294	108	20	65	14	20	160	310	440	495	30	246	126	147	182	FF300
FLSN 160 L	254	294	254	294	108	20	65	14	20	160	310	440	495	30	246	126	147	138	FF300
FLSN 180 MR	279	324	241	295	121	25	80	14	25	180	310	460	515	30	246	126	147	158	FF300
FLSN 180 L	279	330	279	335	121	28	70	14	28	180	350	481	555	42	246	126	147	160	FF300
FLSN 200 L	318	374	305	361	133	28	80	18	44	200	394	530	681	51	246	126	147	248	FF350
FLSN 225 ST	356	420	286	367	149	28	100	18	35	225	394	555	681	51	246	126	147	251	FF400
FLSN 225 MT	356	420	311	367	149	28	100	18	35	225	394	555	681	51	246	126	147	226	FF400
FLSN 225 M	356	426	311	375	149	32	80	18	27	225	540	656	780	70	352	173	210	326	FF400
FLSN 250 M	406	476	349	413	168	32	80	22	27	250	540	681	780	70	352	173	210	269	FF500
FLSN 280 S	457	527	368	432	190	32	80	22	27	280	540	711	860	70	352	173	210	302	FF500
FLSN 280 M	457	527	419	483	190	32	80	22	27	280	540	711	960	70	352	173	210	357	FF500
FLSN 315 ST	508	598	406	547	216	45	90	27	45	315	556	761	1068	68	352	173	210	452	FF600
FLSN 315 M	508	600	457	598	216	45	100	27	45	315	624	835	1203	70	452	217	269	536	FF600
FLSN 315 L	508	600	508	598	216	45	100	27	45	315	632	835	1203	70	452	217	269	485	FF600
FLSN 355 LA/LB	610	710	630	710	254	40	110	27	35	355	700	910	1305	61	452	217	269	427	FF740
FLSN 355 LC/LD	610	710	630	710	254	40	110	27	35	355	700	910	1430	61	452	217	269	552	FF740

\* Dimensions not including cable gland

# TEFV induction motors - Cast iron frame

## FLSE increased safety - FLSN non-sparking

### Dimensions



## F3.4 - Flange mounted IM B5 (IM 3001)

Dimensions in millimetres

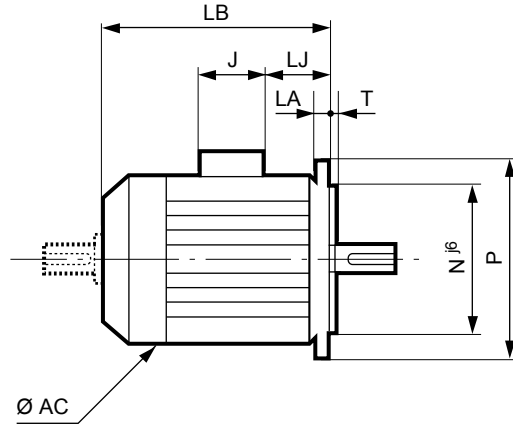
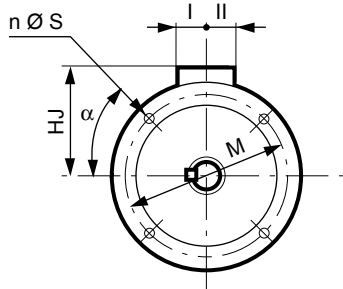

IEC symbol	Flange dimensions							
	M	N	P	T	n	α°	S	LA
FF 165	165	130	200	3.5	4	45	12	10
FF 165	165	130	200	3.5	4	45	12	10
FF 165	165	130	200	3.5	4	45	12	10
FF 165	165	130	200	3.5	4	45	12	10
FF 215	215	180	250	4	4	45	15	11
FF 215	215	180	250	4	4	45	15	11
FF 215	215	180	250	4	4	45	15	11
FF 215	215	180	250	4	4	45	15	11
FF 265	265	230	300	5	4	45	18.5	13
FF 265	265	230	300	5	4	45	18.5	13
FF 265	265	230	300	5	4	45	18.5	13
FF 300	300	250	350	5	4	45	18.5	13
FF 300	300	250	350	5	4	45	18.5	13
FF 300	300	250	350	5	4	45	18.5	13
FF 300	300	250	350	5	4	45	18.5	13
FF 350	350	300	400	5	4	45	19	15
FF 400	400	350	450	5	8	22.3	19	16
FF 400	400	350	450	5	8	22.3	19	16
FF 400	400	350	450	5	8	22.3	19	16
FF 500	500	450	550	5	8	22.3	18	18
FF 500	500	450	550	5	8	22.3	18	22
FF 500	500	450	550	5	8	22.3	18	22
FF 600	600	550	660	6	8	22.3	22	25
FF 600	600	550	660	6	8	22.3	22	25
FF 600	600	550	660	6	8	22.3	22	25
FF 740	740	680	800	6	8	22.3	22	25
FF 740	740	680	800	6	8	22.3	22	25

Type	Main dimensions						
	AC	LB	HJ	LJ	J	I	II*
FLSE/FLSN 80 L	170	216	152	7	136	68	68
FLSE/FLSN 90 S	185	251	158	9	136	68	68
FLSE/FLSN 90 L	185	251	158	9	136	68	68
FLSE 90 LU	185	271	158	9	136	68	68
FLSE/FLSN 100 L	204	300	158	8	136	68	68
FLSE/FLSN 100 LK	226	323	176	55	114	57	57
FLSE/FLSN 112 M	231	309	182	18	136	68	68
FLSE/FLSN 112 MU	231	328	182	18	136	68	68
FLSE/FLSN 132 S	264	385	205	22	136	68	68
FLSE/FLSN 132 M	264	385	205	22	136	68	68
FLSE/FLSN 132 MU	264	412	205	22	136	68	68
FLSN 160 M	310	495	280	30	246	126	147
FLSN 160 L	310	495	280	30	246	126	147
FLSN 180 MR	310	515	280	30	246	126	147
FLSN 180 L	350	555	301	42	246	126	147
FLSN 200 L	394	681	330	51	246	126	147
FLSN 225 ST	394	681	330	51	246	126	147
FLSN 225 MT	394	681	330	51	246	126	147
FLSN 225 M	540	780	431	70	352	173	210
FLSN 250 M	540	780	431	70	352	173	210
FLSN 280 S	540	860	431	70	352	173	210
FLSN 280 M	540	960	431	70	352	173	210
FLSN 315 ST	556	1068	446	68	352	173	210
FLSN 315 M	624	1203	520	70	452	217	269
FLSN 315 L	632	1203	555	70	452	217	269
FLSN 355 LA/LB	700	1305	555	61	452	217	269
FLSN 355 LC/LD	700	1430	555	61	452	217	269

\* Dimensions not including cable gland

Flange mounted motors FF in position IM 3001 are only available up to frame size 225. See section C4 for mounting arrangements.

# TEFV induction motors - Cast iron frame

## FLSE increased safety - FLSN non-sparking

### Dimensions



## F3.5 - Foot and face mounted IM B34 (IM 2101)

Dimensions in millimetres

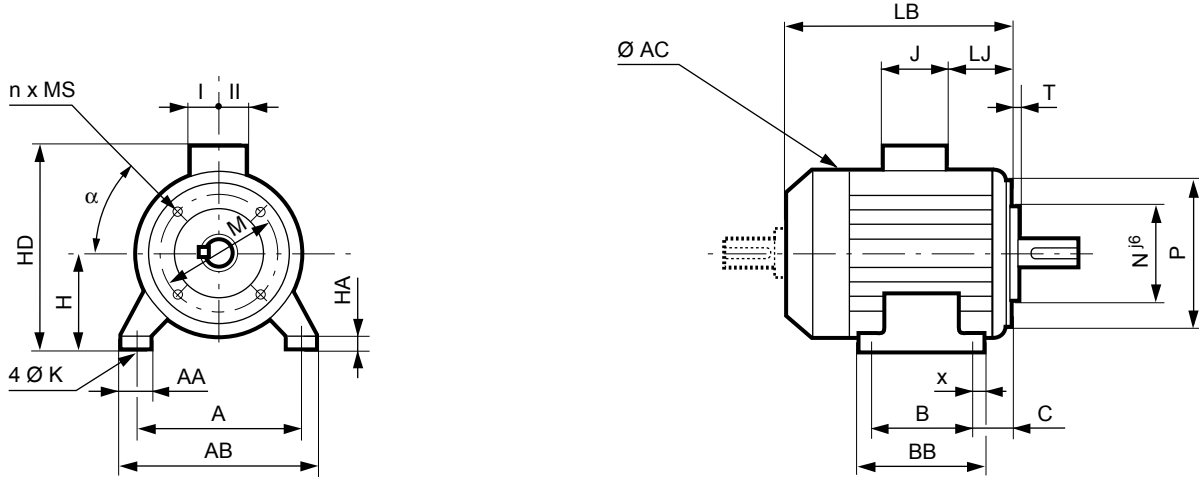

Type	Main dimensions																		
	A	AB	B	BB	C	X	AA	K	HA	H	AC	HD	LB	LJ	J	I	II*	CA	Symbol
FLSE/FLSN 80 L	125	157	100	130	50	20	32	9	11	80	170	231	216	7	136	68	68	83	FT100
FLSE/FLSN 90 S	140	170	100	162	37	27	26	9	10	90	185	251	251	9	136	68	68	126	FT115
FLSE/FLSN 90 L	140	170	125	162	52	27	26	9	10	90	185	251	251	9	136	68	68	110	FT115
FLSE 90 LU	140	172	125	160	52	27	26	9	11	90	185	251	271	9	136	68	68	130	FT115
FLSE/FLSN 100 L	160	196	140	185	63	29	40	12	12	100	204	258	300	8	136	68	68	-	FT130
FLSE/FLSN 100 LK	160	200	140	174	63	22	42	12	12	100	226	288	323	55	114	57	57	119	FT130
FLSE/FLSN 112 M	190	230	140	185	70	32	48	12	12	112	231	294	309	18	136	68	68	-	FT130
FLSE/FLSN 112 MU	190	230	140	185	70	32	48	12	12	112	231	294	328	18	136	68	68	-	FT130
FLSE/FLSN 132 S	216	255	140	240	89	50	63	12	16	132	264	347	385	22	136	68	68	170	FT215
FLSE/FLSN 132 M	216	255	178	240	89	50	63	12	16	132	264	347	385	22	136	68	68	170	FT215
FLSE/FLSN 132 MU	216	255	178	240	89	50	63	12	16	132	264	347	412	22	136	68	68	170	FT215

\* Dimensions not including cable gland

# TEFV induction motors - Cast iron frame

## FLSE increased safety - FLSN non-sparking

### Dimensions



## F3.6 - Face mounted IM B14 (IM 3601)

Dimensions in millimetres

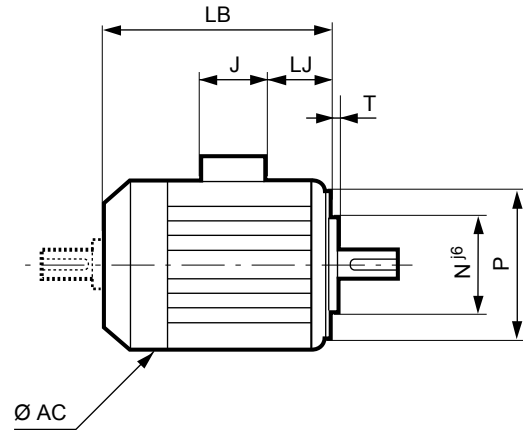
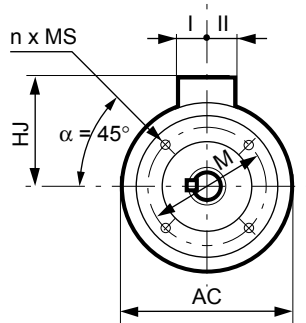

IEC symbol	Faceplate dimensions						
	M	N	P	T	n	$\alpha^\circ$	MS
<b>FT 100</b>	100	80	120	3	4	45	M6
<b>FT 115</b>	115	95	140	3	4	45	M8
<b>FT 115</b>	115	95	140	3	4	45	M8
<b>FT 115</b>	115	95	140	3	4	45	M8
<b>FT 130</b>	130	110	160	3.5	4	45	M8
<b>FT 130</b>	130	110	160	3.5	4	45	M8
<b>FT 130</b>	130	110	160	3.5	4	45	M8
<b>FT 130</b>	130	110	160	3.5	4	45	M8
<b>FT 215</b>	215	180	250	4	4	45	M12
<b>FT 215</b>	215	180	250	4	4	45	M12
<b>FT 215</b>	215	180	250	4	4	45	M12

Type	Main dimensions						
	AC	LB	HJ	LJ	J	I	II*
<b>FLSE/FLSN 80 L</b>	170	216	152	7	136	68	68
<b>FLSE/FLSN 90 S</b>	185	251	158	9	136	68	68
<b>FLSE/FLSN 90 L</b>	185	251	158	9	136	68	68
<b>FLSE 90 LU</b>	185	271	158	9	136	68	68
<b>FLSE/FLSN 100 L</b>	204	300	158	8	136	68	68
<b>FLSE/FLSN 100 LK</b>	226	323	176	55	114	57	57
<b>FLSE/FLSN 112 M</b>	231	309	182	18	136	68	68
<b>FLSE/FLSN 112 MU</b>	231	328	182	18	136	68	68
<b>FLSE/FLSN 132 S</b>	264	385	205	22	136	68	68
<b>FLSE/FLSN 132 M</b>	264	385	205	22	136	68	68
<b>FLSE/FLSN 132 MU</b>	264	412	205	22	136	68	68

\* Dimensions not including cable gland

# 3-phase TEFV induction motors ATEX GAS - Zones 1 & 2



# TEFV induction motors - Aluminium frame

## LSE increased safety - LSN non-sparking

### Electromechanical characteristics



PAGE

## G1 - Selection data - LSE increased safety - Zone 1

G1.1 - 2 poles - 3000 min <sup>-1</sup> - Ex e II T3 .....	74
G1.2 - 4 poles - 1500 min <sup>-1</sup> - Ex e II T3 .....	75
G1.3 - 6 poles - 1000 min <sup>-1</sup> - Ex e II T3 .....	76
G1.4 - 2 poles - 3000 min <sup>-1</sup> - Ex e II T4 .....	77
G1.5 - 4 poles - 1500 min <sup>-1</sup> - Ex e II T4 .....	78

## G2 - Selection data - LSN non-sparking - Zone 2

G2.1 - 2 poles - 3000 min <sup>-1</sup> - Ex nA II T3 .....	80
G2.2 - 4 poles - 1500 min <sup>-1</sup> - Ex nA II T3 .....	81
G2.3 - 6 poles - 1000 min <sup>-1</sup> - Ex nA II T3 .....	82
G2.4 - 8 poles - 750 min <sup>-1</sup> - Ex nA II T3 .....	83

## G3 - Dimensions

G3.1 - Shaft extensions .....	84
G3.2 - Foot mounted <b>IM B3 (IM 1001)</b> .....	85
G3.3 - Foot and flange mounted <b>IM B35 (IM 2001)</b> .....	86
G3.4 - Flange mounted <b>IM B5 (IM 3001)</b> .....	87
G3.5 - Foot and face mounted <b>IM B34 (IM 2101)</b> .....	88
G3.6 - Face mounted <b>IM B14 (IM 3601)</b> .....	89

# TEFV induction motors - Aluminium frame

## LSE increased safety - Zone 1

### Selection data



G1.1 - 2 poles - 3000 min<sup>-1</sup>

**2**  
poles  
3000 min<sup>-1</sup>

Ex e II T3

IP 55  
Cl. F - ΔT 80K  
400 V ± 10%

MAINS SUPPLY Δ 230 / Y 400 V or Δ 400 V 50 Hz

Type	Rated power	Rated speed	Rated torque	Rated current	Power factor	Efficiency IEC 60034-2; 1996	Starting current/ Rated current	Starting torque/ Rated torque	Maximum torque/ Rated torque	Locked rotor time	Moment of inertia	Weight	Noise
	P <sub>N</sub> kW	N <sub>N</sub> min <sup>-1</sup>	M <sub>N</sub> N.m	I <sub>N(400V)</sub> A	Cos φ	η %	I <sub>d</sub> /I <sub>n</sub>	M <sub>d</sub> /M <sub>n</sub>	M <sub>M</sub> /M <sub>n</sub>	t <sub>E</sub> s	J kg.m <sup>2</sup>	IM B3 kg	LP db(A)
LSE 80 L	0.75	2872	2.5	1.6	0.84	79.4	6.8	2.9	3.0	7.6	0.0009	9.7	61
LSE 80 L	1.1	2870	3.75	2.3	0.86	78.5	7.9	3.2	3.1	7.5	0.0011	11.3	61
LSE 90 L	1.5	2860	5	2.9	0.88	83.6	7.8	3.1	3.1	7	0.0017	14	64
LSE 90 L	2.2	2884	7.5	4.2	0.87	85.7	8.5	2.4	3.1	6	0.0022	17.8	64
LSE 100 L	3	2887	10.1	5.6	0.89	86.2	9.9	2.3	2.3	6	0.0029	24	66
LES 112 MU	4	2928	13.5	7.1	0.92	88.6	9.6	2.0	3.0	7	0.0088	39	66
LSE 132 SM	5.5	2926	18.6	9.7	0.91	89.8	7.7	1.7	2.6	8.6	0.016	49	72
LSE 132 SM	7.5	2929	25.4	13.1	0.92	90.4	8.5	1.7	2.6	8.5	0.018	54	72
LSE 160 MP	11	2935	36	19.1	0.92	90.5	9.8	1.7	2.6	6	0.023	72	72
LSE 160 L	15	2933	48.8	26.7	0.89	91	7.8	2.6	3.1	5	0.044	88	72
LSE 180 MT	18.5	2939	60.1	32.7	0.89	91.7	8.3	2.8	3.1	7	0.052	99	72
LSE 200 LT	22	2946	71.3	36.8	0.92	93.7	8.5	2.6	3.3	9	0.089	154	73
LSE 200 L	30	2956	96.9	50.9	0.91	93.5	7.8	2.7	3.1	7	0.12	180	73
LSE 225MT	37	2951	120	62.7	0.91	93.6	7.8	2.7	3.1	6	0.14	200	73
LSE 250 MZ	45	2959	145	76.8	0.9	94	8.5	3.1	3.4	8	0.173	235	78
LSE 280 SC	55	2970	177	92	0.91	94.8	8.5	2.7	3.3	12	0.39	330	79
LSE 280 SC	75	2968	241	129	0.90	94.4	8.5	2.6	3.4	8	0.39	330	79
LSE 280 MC	90	2968	290	154	0.90	94.7	8.4	2.6	3.3	10	0.47	375	79

# TEFV induction motors - Aluminium frame

## LSE increased safety - Zone 1

### Selection data



G1.2 - 4 poles - 1500 min<sup>-1</sup>

**4**  
poles  
1500 min<sup>-1</sup>

Ex e II T3

IP 55  
Cl. F - ΔT 80K  
400 V ± 10%

MAINS SUPPLY Δ 230 / Y 400 V or Δ 400 V 50 Hz

Type	Rated power	Rated speed	Rated torque	Rated current	Power factor	Efficiency IEC 60034-2; 1996	Starting current/ Rated current	Starting torque/ Rated torque	Maximum torque/ Rated torque	Locked rotor time	Moment of inertia	Weight	Noise
	P <sub>N</sub> kW	N <sub>N</sub> min <sup>-1</sup>	M <sub>N</sub> N.m	I <sub>N(400V)</sub> A	Cos φ	η %	I <sub>d</sub> /I <sub>n</sub>	M <sub>d</sub> /M <sub>n</sub>	M <sub>m</sub> /M <sub>n</sub>	t <sub>E</sub> s	J kg.m <sup>2</sup>	IM B3 kg	LP db(A)
LSE 80 L	0.75	1430	5	2	0.72	74	5.3	2.2	2.3	10	0.0024	10.9	47
LSE 90 L	1.1	1440	7.5	2.5	0.83	78.8	6.0	2.2	2.6	8.1	0.0032	13.5	48
LSE 90 L	1.5	1450	10	3.7	0.75	78	6.2	1.7	2.0	7.2	0.0032	13.5	48
LSE 100 L	2.2	1444	15	4.5	0.85	83.5	6.5	2.1	2.2	7.5	0.0055	22.5	48
LSE 100 L	3	1423	20	6.2	0.85	83	6.8	2.0	2.1	7	0.0055	22.5	48
LSE 112 MU	4	1458	27.2	7.7	0.86	86.9	7.6	2.0	2.1	8.4	0.014	36.5	49
LSE 132 SM	5.5	1464	37.4	10.3	0.87	88.4	7.9	1.8	2.5	9	0.019	54.7	62
LSE 132 M	7.5	1457	50	14.8	0.85	86	7.9	1.9	2.6	5.5	0.023	59.9	62
LSE 160 MR	11	1468	74.7	22	0.82	89	9.8	2.4	3.1	5	0.035	78	62
LSE 160 L	15	1460	98.5	28.2	0.85	90.3	7.8	2.8	3.3	7	0.085	100	62
LSE 180 MR	18.5	1456	121	33.7	0.87	91.2	8.3	3.0	3.4	6	0.096	112	64
LSE 180 LU	22	1464	144	39.7	0.87	91.9	7.1	3.0	3.0	6	0.151	165	64
LSE 200 L	30	1472	195	54.8	0.85	93	6.6	2.7	2.6	6	0.24	205	64
LSE 225 SR	37	1471	240	68.2	0.84	93.2	6.6	3.0	2.9	12	0.29	235	64
LSE 250 ME	45	1480	290	81.3	0.85	94	7.3	2.7	2.6	12	0.63	320	66
LSE 250 ME	55	1478	355	102	0.84	93.6	7.0	2.7	2.8	10	0.63	320	66
LSE 280 SC	56	1478	485	138	0.84	94.2	7.2	2.8	2.9	6	0.83	380	69
LSE 280 MD	90	1479	581	162	0.85	95	8.0	3.2	3.0	8	1.03	450	69

# TEFV induction motors - Aluminium frame

## LSE increased safety - Zone 1

### Selection data



G1.3 - 6 poles - 1000 min<sup>-1</sup>

**6**  
poles  
1000 min<sup>-1</sup>

Ex e II T3

IP 55  
Cl. F - ΔT 80K  
400 V ± 10%

MAINS SUPPLY Δ 230 / Y 400 V or Δ 400 V 50 Hz

Type	Rated power P <sub>N</sub> kW	Rated speed N <sub>N</sub> min <sup>-1</sup>	Rated torque M <sub>N</sub> N.m	Rated current I <sub>N(400V)</sub> A	Power factor Cos φ	Efficiency IEC 60034-2; 1996 η %	Starting current/ Rated current I <sub>d</sub> /I <sub>N</sub>	Starting torque/ Rated torque M <sub>d</sub> /M <sub>N</sub>	Maximum torque/ Rated torque M <sub>M</sub> /M <sub>N</sub>	Locked rotor time t <sub>E</sub> s	Moment of inertia J kg.m <sup>2</sup>	Weight IM B3 kg	Noise LP db(A)
LSE 80 L	0.37	948	3.7	1.2	0.68	65.3	3.7	1.6	2.0	12	0.0032	9.7	41
LSE 80 L	0.55	955	5.5	1.8	0.64	68.6	4.5	2.1	2.4	8.4	0.0042	11	41
LSE 90 L	0.75	935	7.5	2.2	0.67	75	4.6	2.6	2.6	10.5	0.0039	13.5	51
LSE 90 LU	1.1	915	11.5	2.9	0.79	72.8	5.6	2.8	2.9	9	0.0051	17	51
LSE 100 L	1.5	928	15	4.2	0.67	76.8	5.0	2.7	2.7	8.5	0.0069	20	50
LSE 112 M	2.2	960	22.7	5.3	0.76	81	6.2	2.2	2.7	7.3	0.0087	24.2	51
LSE 132 SM	3	963	30	7	0.74	84.6	4.3	1.2	1.6	6.9	0.026	43.4	55
LSE 132 M	4	966	40	9.1	0.74	85.9	4.6	1.3	1.6	7.1	0.034	59.4	55
LSE 132 MU	5.5	963	55	12.3	0.75	86.4	4.7	1.4	1.6	7.1	0.043	66.5	55
LSE 160 M	7.5	965	74.2	15.9	0.79	86	5.0	1.7	2.4	12	0.084	81	56
LSE 160 L	11	963	109	23.6	0.78	86.2	6.0	1.8	2.5	12	0.126	105	56
LSE 180 L	15	971	140	30.6	0.8	88.5	6.4	2.4	2.7	6	0.191	135	60
LSE 200 LT	18.5	972	172	38.9	0.77	89.2	6.5	2.5	2.8	6	0.237	160	62
LSE 200 L	22	974	216	44.1	0.8	90.1	6.2	2.0	2.7	10	0.287	190	62
LSE 225 MR	30	976	294	61.9	0.77	90.8	6.7	2.7	3.0	8	0.38	235	63
LSE 250 ME	37	978	361	71.1	0.81	68.0	6.2	2.3	2.5	12	0.85	305	65
LSE 280 SC	45	978	439	86.5	0.81	68.0	6.2	2.3	2.5	12	0.99	340	65
LSE 280 MC	55	978	537	106	0.81	68.0	6.0	2.4	2.5	12	1.19	385	65

# TEFV induction motors - Aluminium frame

## LSE increased safety - Zone 1

### Selection data



G1.4 - 2 poles - 3000 min<sup>-1</sup>

**2**  
poles  
3000 min<sup>-1</sup>

Ex e II T4

IP 55  
Cl. F - ΔT 80K  
400 V ± 10%

MAINS SUPPLY Δ 230 / Y 400 V or Δ 400 V 50 Hz

	Rated power	Rated speed	Rated torque	Rated current	Power factor	Efficiency IEC 60034-2; 1996	Starting current/ Rated current	Starting torque/ Rated torque	Maximum torque/ Rated torque	Locked rotor time	Moment of inertia	Weight	Noise
Type	P <sub>N</sub> kW	N <sub>N</sub> min <sup>-1</sup>	M <sub>N</sub> N.m	I <sub>N(400V)</sub> A	Cos φ	η %	I <sub>d</sub> /I <sub>n</sub>	M <sub>d</sub> /M <sub>n</sub>	M <sub>M</sub> /M <sub>n</sub>	t <sub>E</sub> s	J kg.m <sup>2</sup>	IM B3 kg	LP db(A)
LSE 80 L	0.75	2879	2.5	1.5	0.84	83.2	7.3	2.5	3.0	5	0.0011	11.3	61
LSE 90 L	1.1	2865	3.7	2.1	0.91	83.9	7.6	2.1	2.7	5	0.0021	16	64
LSE 90 L	1.5	2865	5	2.9	0.92	84	8.6	3.2	3.1	5	0.0021	16	64
LSE 100 L	2.2	2850	7.4	4.2	0.93	84.5	8.8	2.8	3.4	5	0.0029	24	66
LSE 112 MU	3	2924	10.1	5.3	0.94	86.7	9.1	2.7	3.4	5	0.0088	39	66
LSE 132 SM	4	2944	13.5	7.5	0.87	88.4	9.7	2.1	3.2	5	0.016	49	72
LSE 132 SM	5.5	2953	18.6	9.7	0.92	89.5	8.9	1.7	2.7	5	0.018	54	72
LSE 160 MP	7.5	2933	25.4	12.9	0.94	89.9	5.9	1.4	2.2	7.3	0.023	68	72

# TEFV induction motors - Aluminium frame

## LSE increased safety - Zone 1

### Selection data



G1.5 - 4 poles - 1500 min<sup>-1</sup>

**4**  
poles  
1500 min<sup>-1</sup>

Ex e II T4

IP 55  
Cl. F - ΔT 80K  
400 V ± 10%

MAINS SUPPLY Δ 230 / Y 400 V or Δ 400 V 50 Hz

Type	Rated power	Rated speed	Rated torque	Rated current	Power factor	Efficiency IEC 60034-2; 1996	Starting current/ Rated current	Starting torque/ Rated torque	Maximum torque/ Rated torque	Locked rotor time	Moment of inertia	Weight	Noise
	P <sub>N</sub> kW	N <sub>N</sub> min <sup>-1</sup>	M <sub>N</sub> N.m	I <sub>N(400V)</sub> A	Cos φ	η %	I <sub>d</sub> /I <sub>n</sub>	M <sub>d</sub> /M <sub>n</sub>	M <sub>M</sub> /M <sub>n</sub>	t <sub>E</sub> s	J kg.m <sup>2</sup>	IM B3 kg	LP db(A)
LSE 80 L	0.55	1425	3.75	1.4	0.76	75	5.2	1.9	2.2	9	0.0024	10.9	47
LSE 90 L	0.75	1450	5	1.7	0.81	80.5	6.5	2.0	2.7	6	0.0032	13.5	48
LSE 90 L	1.1	1447	7.5	2.5	0.78	82.1	6.7	1.8	2.3	5.5	0.0037	15.2	48
LSE 100 L	1.5	1442	10	3.3	0.8	82.8	6.3	1.8	2.2	6	0.0064	25.5	48
LSE 100 LG	2.2	1466	15	4.4	0.84	87.3	7.3	1.8	2.2	5	0.0109	30.5	48
LSE 112 MU	3	1464	20	5.9	0.85	87.8	7.6	2.0	2.2	5	0.014	36.5	49
LSE 132 SM	4	1465	27.5	7.4	0.89	88	7.7	1.8	2.6	5	0.019	54.7	62
LSE 132 SM	5.5	1466	37.5	10.4	0.87	89.1	8.1	2.0	2.7	5	0.023	59.9	62
LSE 132 MU	7.5	1461	50	13.8	0.88	89.2	7.4	1.6	2.3	5	0.0306	65.5	62

**TEFV induction motors - Aluminium frame**  
**LSE increased safety - Zone 1**  
**Selection data**



# TEFV induction motors - Aluminium frame

## LSN non-sparking - Zone 2

### Selection data



G2.1 - 2 poles - 3000 min<sup>-1</sup>

**2**  
poles  
3000 min<sup>-1</sup>

Ex nA II T3

IP 55  
Cl. F - ΔT 80K  
400 V ± 10%

MAINS SUPPLY Δ 230 / Y 400 V or Δ 400 V 50 Hz

Type	Rated power	Rated speed	Rated torque	Rated current	Power factor			Efficiency IEC 60034-2; 1996			Starting current/ Rated current	Starting torque/ Rated torque	Maximum torque/ Rated torque	Moment of inertia	Weight	Noise
	P <sub>N</sub> kW	N <sub>N</sub> min <sup>-1</sup>	M <sub>N</sub> N.m	I <sub>N(400V)</sub> A	Cos φ			η			Id/In	Md/Mn	M <sub>m</sub> /Mn	J kg.m <sup>2</sup>	IM B3 kg	LP db(A)
LSN 80 L	0.75	2840	2.5	1.64	0.87	0.8	0.68	76	76.5	74	5.9	2.4	2.2	0.0007	8.2	61
LSN 80 L	1.1	2837	3.7	2.4	0.84	0.77	0.65	78	78.5	76.6	5.8	2.7	2.4	0.0009	9.7	61
LSN 80 L	1.5	2859	5.01	3.2	0.83	0.76	0.62	80.3	80.4	78	7.0	3.2	2.8	0.0011	11.3	61
LSN 90 S	1.5	2870	4.99	3.4	0.81	0.72	0.58	79.6	78.9	75.1	8.0	3.9	4.0	0.0014	12	64
LSN 90 L	1.8	2865	6	3.6	0.86	0.8	0.69	83.1	83.4	81.7	8.0	3.6	3.6	0.0017	14	64
LSN 90 L	2.2	2862	7.34	4.3	0.88	0.83	0.73	83.6	84	82.9	7.7	3.7	3.3	0.0021	16	64
LSN 100 L	3	2868	9.99	6.3	0.81	0.73	0.59	83.9	83.8	80.8	7.5	3.8	3.9	0.0022	20	66
LSN 112 M	4	2877	13.3	7.9	0.85	0.78	0.65	86	86.1	84.4	7.8	2.9	2.9	0.0029	24.4	66
LSN 112 MG	5.5	2916	18	10.5	0.88	0.81	0.71	86.6	87.2	85.6	9.0	3.1	3.5	0.0076	33	66
LSN 132 S	5.5	2916	18	10.5	0.88	0.81	0.71	86.6	87.2	85.6	9.0	3.1	3.5	0.0076	34.4	72
LSN 132 S	7.5	2905	24.5	14.7	0.85	0.78	0.63	86.5	86.4	84.5	8.7	3.4	3.6	0.0088	39	72
LSN 132 M	9	2910	29.5	17.3	0.85	0.8	0.71	88.1	88.4	87.5	8.6	2.5	3.5	0.016	49	72
LSN 132 M	11	2944	35.7	20.7	0.86	0.81	0.69	89.4	89.4	87.7	7.5	2.7	3.4	0.018	54	72
LSN 160 MP	11	2944	35.7	20.7	0.86	0.81	0.69	89.4	89.4	87.7	7.5	2.7	3.4	0.019	62	72
LSN 160 MP	15	2935	48.8	28.4	0.85	0.79	0.71	90	90.1	85.1	8.1	3.0	3.5	0.023	72	72
LSN 160 L	18.5	2934	60.2	33.7	0.87	0.83	0.75	91	91.2	90.4	8.0	3.0	3.3	0.044	88	72
LSN 180 MT	22	2938	71.5	39.9	0.87	0.84	0.76	91.5	91.8	91.2	8.1	3.1	3.1	0.052	99	72
LSN 200 LT	30	2946	97.2	52.1	0.9	0.87	0.82	92.4	92.7	92.1	8.6	2.7	3.4	0.089	154	73
LSN 200 L	37	2950	120	64.6	0.89	0.87	0.82	92.9	93	92.2	7.4	2.6	3.0	0.12	180	73
LSN 225 MT	45	2950	146	78	0.9	0.87	0.82	93.3	93.4	93.1	7.5	2.8	3.1	0.14	200	73
LSN 250 MZ	55	2956	178	95.2	0.89	0.86	0.8	93.7	93.7	93.1	8.3	3.1	3.4	0.173	235	78
LSN 280 SC	75	2968	241	127	0.9	0.87	0.82	94.4	94.4	93.8	8.5	2.6	3.4	0.39	330	79
LSN 280 MC	90	2968	290	152	0.9	0.88	0.83	94.7	94.7	94.1	8.4	2.6	3.3	0.47	375	79

# TEFV induction motors - Aluminium frame

## LSN non-sparking - Zone 2

### Selection data



G2.2 - 4 poles - 1500 min<sup>-1</sup>

**4**  
poles  
1500 min<sup>-1</sup>

Ex nA II T3

IP 55  
Cl. F - ΔT 80K  
400 V ± 10%

MAINS SUPPLY Δ 230 / Y 400 V or Δ 400 V 50 Hz

Type	Rated power	Rated speed	Rated torque	Rated current	Power factor			Efficiency IEC 60034-2; 1996			Starting current/ Rated current	Starting torque/ Rated torque	Maximum torque/ Rated torque	Moment of inertia	Weight	Noise
	P <sub>N</sub> kW	N <sub>N</sub> min <sup>-1</sup>	M <sub>N</sub> N.m	I <sub>N(400V)</sub> A	Cos φ			η			Id/In	Md/Mn	M <sub>m</sub> /Mn	J kg.m <sup>2</sup>	IM B3 kg	LP db(A)
LSN 80 L	0.55	1410	3.72	1.42	0.76	0.68	0.55	73.4	69.3	62	4.5	2.0	2.3	0.0013	8.2	47
LSN 80 L	0.75	1400	5.12	2.01	0.77	0.71	0.59	70	70	66	4.5	2.0	2.2	0.0018	9.3	47
LSN 80 L	0.9	1425	6.03	2.44	0.73	0.67	0.54	73	73	70	5.8	3.0	3.0	0.0024	10.9	47
LSN 90 S	1.1	1429	7.35	2.5	0.84	0.77	0.64	76.8	78.4	77.1	4.8	1.6	2.0	0.0026	11.5	48
LSN 90 L	1.5	1428	10	3.4	0.82	0.74	0.6	78.5	79.4	77.5	5.3	1.8	2.3	0.0032	13.5	48
LSN 90 L	1.8	1438	12	4	0.82	0.75	0.61	80.1	80.8	79	6.0	2.1	3.2	0.0037	15.2	48
LSN 100 L	2.2	1436	14.6	4.8	0.81	0.73	0.59	81	81.5	79.8	5.9	2.1	2.5	0.0043	20	48
LSN 100 L	3	1437	19.9	6.5	0.81	0.72	0.59	82.6	82.6	80.8	6.0	2.5	2.8	0.0055	22.5	48
LSN 112 M	4	1438	26.6	8.3	0.83	0.76	0.57	84.2	84.2	83.4	7.1	2.5	3.0	0.0067	24.9	49
LSN 132 S	5.5	1447	36.7	11.1	0.83	0.79	0.67	85.7	86.4	85.8	6.3	2.4	2.8	0.014	36.5	62
LSN 132 M	7.5	1451	49.4	15.2	0.82	0.74	0.61	87	86.4	84.9	7.0	2.4	2.9	0.019	54.7	62
LSN 132 M	9	1455	59.1	18.1	0.82	0.74	0.62	87.7	87.6	86.2	6.9	2.2	3.1	0.023	59.9	62
LSN 160 MP	11	1454	72.2	21	0.86	0.79	0.67	88.4	88.6	87.4	7.7	2.3	3.2	0.03	70	62
LSN 160 LR	15	1453	98.6	28.8	0.84	0.78	0.69	89.4	89.8	88.4	7.5	2.9	3.6	0.036	86	62
LSN 180 MT	18.5	1456	121	35.2	0.84	0.79	0.67	90.3	90.8	90.3	7.6	2.7	3.2	0.085	100	64
LSN 180 LR	22	1456	144	41.7	0.84	0.79	0.68	90.7	91.2	90.9	7.9	3.0	3.3	0.096	112	64
LSN 200 LT	30	1460	196	56.3	0.84	0.8	0.69	91.5	92	91.5	6.6	2.9	2.9	0.151	165	64
LSN 225 ST	37	1468	241	68.7	0.84	0.8	0.7	92.5	93.1	92.9	6.3	2.7	2.6	0.24	205	64
LSN 225 MR	45	1468	293	83.3	0.84	0.8	0.7	92.8	93.3	93	6.3	2.7	2.6	0.29	235	64
LSN 250 ME	55	1478	355	101	0.84	0.8	0.71	93.6	93.8	93.2	7.0	2.7	2.8	0.63	320	66
LSN 280 SC	75	1478	485	137	0.84	0.8	0.71	94.2	94.4	93.8	7.2	2.8	2.9	0.83	380	69
LSN 280 MD	90	1478	582	164	0.84	0.8	0.71	94.4	94.5	93.8	7.6	3.0	3.0	1.03	450	69

# TEFV induction motors - Aluminium frame

## LSN non-sparking - Zone 2

### Selection data



G2.3 - 6 poles - 1000 min<sup>-1</sup>

**6**  
poles  
1000 min<sup>-1</sup>

Ex nA II T3

IP 55  
Cl. F - ΔT 80K  
400 V ± 10%

MAINS SUPPLY Δ 230 / Y 400 V or Δ 400 V 50 Hz

Type	Rated power	Rated speed	Rated torque	Rated current	Power factor			Efficiency IEC 60034-2; 1996			Starting current/ Rated current	Starting torque/ Rated torque	Maximum torque/ Rated torque	Moment of inertia	Weight	Noise
	P <sub>N</sub> kW	N <sub>N</sub> min <sup>-1</sup>	M <sub>N</sub> N.m	I <sub>N(400V)</sub> A	4/4	3/4	2/4	4/4	3/4	2/4	Id/In	Md/Mn	M <sub>m</sub> /Mn	J kg.m <sup>2</sup>	IM B3 kg	LP db(A)
LSN 80 L	0.25	955	2.5	0.85	0.67	0.64	0.48	63.1	63	56	3.9	1.6	1.8	0.0024	8.4	41
LSN 80 L	0.37	950	3.72	1.1	0.72	0.67	0.57	66	61	59	4.3	1.7	2.2	0.0032	9.7	41
LSN 80 L	0.55	950	5.53	1.8	0.64	0.6	0.47	68	63	55	4.9	2.1	2.6	0.0042	11	41
LSN 90 S	0.75	930	7.7	2.1	0.77	0.66	0.54	68.5	65	60	4.2	2.4	2.6	0.0039	13.5	51
LSN 90 L**	1.1	915	11.5	3	0.76	0.67	0.55	70	70	66	4.7	2.4	2.5	0.0048	15.2	51
LSN 100 L**	1.5	905	15.8	4.2	0.74	0.62	0.52	69	69	65	4.5	2.5	2.7	0.0058	20	50
LSN 112 M**	2.2	905	23.2	5.8	0.76	0.66	0.53	72	72	68	5.6	2.8	2.7	0.0087	24.2	51
LSN 132 M**	3	957	30.3	6.8	0.75	0.66	0.53	81.1	78	75	6.0	2.0	2.6	0.018	38.3	51
LSN 132 M	4	961	39.7	9.3	0.75	0.66	0.56	83.6	83	78	5.9	2.5	2.9	0.034	53.3	55
LSN 132 M**	5.5	960	54.7	13.3	0.71	0.65	0.52	84.1	83.5	80	5.5	2.5	2.8	0.039	59.4	55
LSN 160 M	7.5	969	73.9	16.3	0.79	0.74	0.63	85.2	84.8	82.6	5.2	1.7	2.5	0.089	77	56
LSN 160 L	11	968	109	23.4	0.78	0.71	0.64	86.3	86.5	85	5.3	1.8	2.6	0.105	85	56
LSN 180 L	15	972	147	30.1	0.81	0.76	0.65	87.1	87.3	86.1	6.8	2.3	2.8	0.192	135	60
LSN 200 LT	18.5	970	182	37	0.81	0.76	0.65	89	89.3	88.1	6.4	2.4	2.8	0.236	160	62
LSN 200 L	22	972	216	43.6	0.81	0.76	0.65	89.9	90.1	89	6.0	2.0	2.7	0.295	190	62
LSN 225 MR	30	968	296	59.5	0.81	0.79	0.72	89.9	90.3	89.2	6.0	2.2	2.5	0.39	235	63
LSN 250 ME	37	978	361	71.1	0.81	0.79	0.69	92.7	93.2	92.9	6.2	2.3	2.5	0.85	305	65
LSN 280 SC	45	978	439	86.5	0.81	0.79	0.69	92.7	93.2	92.9	6.2	2.3	2.5	0.99	340	65
LSN 280 MC	55	978	537	106	0.81	0.79	0.72	92.6	93.3	93.1	6.0	2.4	2.5	1.19	385	65

# TEFV induction motors - Aluminium frame

## LSN non-sparking - Zone 2

### Selection data



G2.4 - 8 poles - 750 min<sup>-1</sup>

**8**  
poles  
750 min<sup>-1</sup>

Ex nA II T3

IP 55  
Cl. F - ΔT 80K  
400 V ± 10%

MAINS SUPPLY Δ 230 / Y 400 V or Δ 400 V 50 Hz

Type	Rated power	Rated speed	Rated torque	Rated current	Power factor			Efficiency IEC 60034-2; 1996			Starting current/ Rated current	Starting torque/ Rated torque	Maximum torque/ Rated torque	Moment of inertia	Weight	Noise
	P <sub>N</sub> kW	N <sub>N</sub> min <sup>-1</sup>	M <sub>N</sub> N.m	I <sub>N(400V)</sub> A	Cos φ			η			Id/In	Md/Mn	M <sub>m</sub> /Mn	J kg.m <sup>2</sup>	IM B3 kg	LP db(A)
					4/4	3/4	2/4	4/4	3/4	2/4						
LSN 80 L	0.18	705	2.44	0.79	0.63	0.54	0.45	52	48	43	2.9	1.5	1.9	0.0031	9.7	41
LSN 80 L	0.25	700	3.41	0.98	0.68	0.6	0.51	54	52	45	2.8	1.7	1.9	0.0041	11.3	41
LSN 90 L	0.37	685	5.16	1.2	0.72	0.63	0.52	62	62	56	3.8	1.7	1.8	0.0038	13.5	43
LSN 90 S	0.37	685	5.16	1.2	0.72	0.63	0.52	62	62	56	3.8	1.7	1.8	0.0038	13.5	43
LSN 90 L	0.55	670	7.84	1.7	0.72	0.61	0.52	63.5	62	59	3.5	1.7	1.7	0.0047	15.2	43
LSN 100 L	0.75	670	10.7	2.4	0.71	0.58	0.47	63.5	61.5	55	3.5	1.8	2.2	0.0047	18	43
LSN 100 L	1.1	670	15.7	3.7	0.68	0.6	0.49	63	62.5	58	3.7	2.0	2.2	0.0068	21.8	43
LSN 112 MG	1.5	710	20.2	4.7	0.64	0.55	0.43	72	69	62.5	3.8	2.0	2.1	0.015	24	49
LSN 132 SM	2.2	713	29.5	6.1	0.68	0.56	0.45	77.1	77.5	71	4.0	1.7	2.0	0.025	45.6	54
LSN 132 M	3	712	40.2	8	0.65	0.56	0.45	79.8	82.9	79	4.3	1.9	2.2	0.033	53.9	54
LSN 160 M	4	718	53.2	11	0.63	0.55	0.43	83.3	83.4	81.3	3.9	1.7	2.3	0.068	84	66
LSN 160 M	5.5	716	73.4	15.1	0.63	0.55	0.43	83.3	83.5	81.8	3.9	1.7	2.3	0.071	89	66
LSN 160 L	7.5	714	100	20.6	0.63	0.55	0.43	83.4	84	82.6	3.9	1.9	2.3	0.09	101	66
LSN 180 L	11	720	146	25.6	0.72	0.68	0.57	86	86.3	84.2	3.8	1.4	1.9	0.205	140	68
LSN 200 L	15	725	198	32.9	0.75	0.7	0.57	87.7	87.9	86.3	4.4	1.6	2.1	0.27	185	65
LSN 225 ST	18.5	725	244	42.4	0.72	0.66	0.54	87.5	87.7	86.2	4.2	1.6	2.1	0.33	210	65
LSN 225 MR	22	725	290	51.9	0.7	0.63	0.51	87.4	87.2	85.1	4.4	1.9	2.3	0.4	240	65
LSN 250 ME	30	730	392	60.3	0.79	0.73	0.63	90.9	91.2	90.1	5.8	1.9	2.7	0.99	330	65
LSN 280 SC	37	730	484	74.3	0.79	0.73	0.63	91	91.4	90.7	5.6	1.8	2.6	1.19	370	65
LSN 280 MD	45	728	590	91.4	0.78	0.73	0.63	91.1	91.7	91.1	5.4	1.8	2.6	1.39	430	65

# TEFV induction motors - Aluminium frame

## LSE increased safety - LSN non-sparking

### Dimensions



## G3.1 - Shaft extensions

Dimensions in millimetres

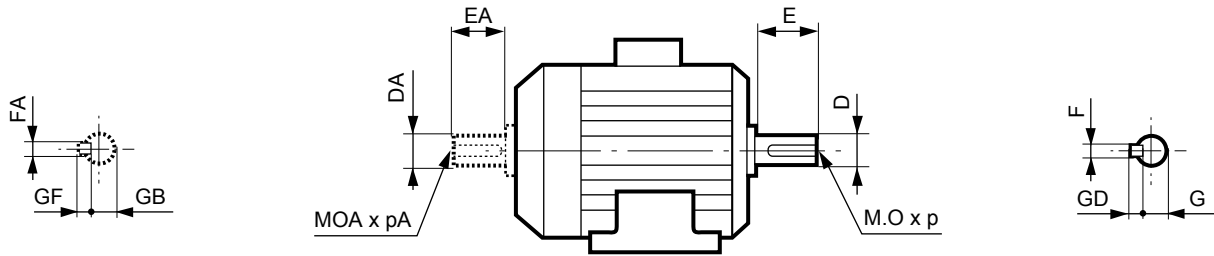

Type	Main shaft extensions																		
	4, 6 and 8 poles									2 poles									
	F	GD	D	G	E	O	p	L	LO	F	GD	D	G	E	O	p	L	LO	
LSE/LSN 80 L	6	6	19j6	15.5	40	6	16	30	6	0	6	6	19j6	15.5	40	6	16	30	6
LSE/LSN 90 S/L	8	7	24j6	20	50	8	19	40	6	0	8	7	24j6	20	50	8	19	40	6
LSE/LSN 100 L	8	7	28j6	24	60	10	22	50	6	0	8	7	28j6	24	60	10	22	50	6
LSE/LSN 112 M/MG/MU	8	7	28j6	24	60	10	22	50	6	0	8	7	28j6	24	60	10	22	50	6
LSE/LSN 132 S/SM/M	10	8	38k6	33	80	12	28	63	10	0	10	8	38k6	33	80	12	28	63	10
LSE/LSN 160 M/MP/MR/L/LR	12	8	42k6	37	110	16	36	100	6	0	12	8	42k6	37	110	16	36	100	6
LSE/LSN 180 MR/MT/L/LR/LU	14	9	48k6	42.5	110	16	36	98	12	0	14	9	48k6	42.5	110	16	36	98	12
LSE/LSN 200 L/LT	16	10	55m6	49	110	20	42	97	13	0	16	10	55m6	49	110	20	42	97	13
LSE/LSN 225 SR/ST/MG/MR/MT	18	11	60m6	53	140	20	42	126	14	0	18	11	60m6	49	110	20	42	97	13
LSE/LSN 250 ME/MF/MZ	18	11	65m6	58	140	20	42	126	14	0	18	11	60m6	53	140	20	42	126	14
LSE/LSN 280 SC/SD/MC/MD	20	12	75m6	67.5	140	20	42	125	15	0	18	11	65m6	58	140	20	42	125	14

Type	Secondary shaft extensions																		
	4, 6 and 8 poles									2 poles									
	FA	GF	DA	GB	EA	OA	pA	L'	LO'	FA	GF	DA	GB	EA	OA	pA	L'	LO'	
LSE/LSN 80 L	5	5	14j6	11	30	5	15	25	3.5	0	5	5	14j6	11	30	5	15	25	3.5
LSE/LSN 90 S/SL/L/LU	6	6	19j6	15.5	40	6	16	30	6	0	6	6	19j6	15.5	40	6	16	30	6
LSE/LSN 100 L	8	7	24j6	20	50	8	19	40	6	0	8	7	24j6	20	50	8	19	40	6
LSE/LSN 112 M/MG/MU	8	7	24j6	20	50	8	19	40	6	0	8	7	24j6	20	50	8	19	40	6
LSE/LSN 132 S/SM/M	8	7	28k6	24	60	10	22	50	6	0	8	7	28k6	24	60	10	22	50	6
LSE/LSN 160 M/MP/MR/L/LR/LU	12	8	38k6	37	80	16	36	100	6	0	12	8	38k6	37	80	16	36	100	6
LSE/LSN 180 MR/MT/L/LR/LU	14	9	48k6	42.5	110	16	36	98	12	0	14	9	48k6	42.5	110	16	36	98	12
LSE/LSN 200 L/LT/LU	16	10	55m6	49	110	20	42	97	13	0	16	10	55m6	49	110	20	42	97	13
LSE/LSN 225 SR/ST/MG/MR/MT	18	11	60m6	53	140	20	42	126	14	0	18	11	60m6	49	110	20	42	97	13
LSE/LSN 250 ME/MF/MZ	18	11	60m6	53	140	20	42	126	14	0	18	11	60m6	53	140	20	42	126	14
LSE/LSN 280 SC/SD/MC/MD	18	11	65m6	58	140	20	42	126	14	0	18	11	65m6	58	140	20	42	126	14

# TEFV induction motors - Aluminium frame

## LSE increased safety - LSN non-sparking

### Dimensions



## G3.2 - Foot mounted IM B3 (IM 1001)

Dimensions in millimetres

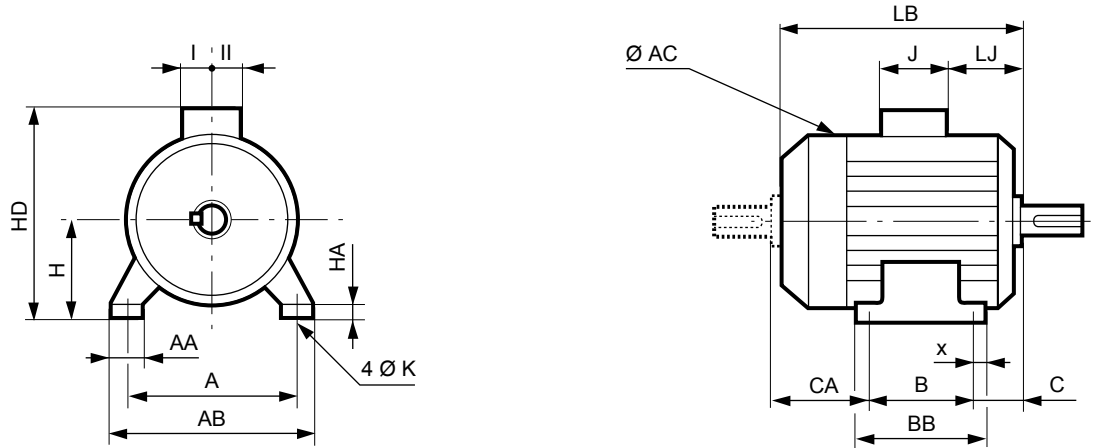

Type	Main dimensions																	
	A	AB	B	BB	C	X	AA	K	HA	H	AC	HD	LB	LJ	J	I	II*	CA
LSE/LSN 80 L	125	157	100	120	50	10	29	9	10	80	170	227	215	7	124	62	62	68
LSE/LSN 90 S	140	172	100	120	56	10	37	10	11	90	190	247	218	7	124	62	62	66
LSE/LSN 90 SL/L	140	172	125	162	56	28	37	10	11	90	190	247	245	7	124	62	62	68
LSE/LSN 100 L	160	196	140	165	63	12	40	12	13	100	200	262	290	7	124	62	62	93
LSE/LSN 112 M	190	220	140	165	70	12	45	12	14	112	200	274	290	16	124	62	62	86
LSE/LSN 112 MG	190	220	140	165	70	12	52	12	14	112	235	284	315	16	124	62	62	110
LSE/LSN 112 MU	190	220	140	165	70	12	52	12	14	112	235	284	334	16	124	62	62	130
LSE/LSN 132 S	216	250	140	170	89	16	50	12	15	132	235	304	350	33	124	62	62	128
LSE/LSN 132 SM/M	216	250	178	208	89	16	59	12	18	132	280	331	387	17	124	62	62	126
LSE/LSN 132 MU	216	250	178	208	89	16	59	12	18	132	280	331	410	17	124	62	62	148
LSE/LSN 160 MP	254	294	210	294	108	20	64	14.5	25	160	315	361	468	48.5	124	62	62	154
LSE/LSN 160 M	254	294	210	294	108	20	60	14.5	25	160	316	409	495	54.8	205	115	98	182
LSE/LSN 160 LR	254	294	254	294	108	20	64	14.5	25	160	315	361	495	48.5	124	62	62	138
LSE/LSN 160 MR	254	294	210	294	108	20	64	14.5	25	160	316	361	495	48.5	124	62	62	138
LSE/LSN 160 L	254	294	254	294	108	20	60	14.5	25	160	316	409	495	54.8	205	115	98	138
LSE/LSN 180 MT	279	324	241	316	121	20	79	14.5	28	180	316	453	495	39.2	217	103	145	138
LSE/LSN 180 MR	279	324	241	316	121	20	79	14.5	28	180	316	453	520	39.2	217	103	145	163
LSE/LSN 180 LR	279	324	279	316	121	20	79	14.5	28	180	316	460	520	39.2	217	103	145	125
LSE/LSN 180 L	279	339	279	329	121	25	86	14.5	25	180	350	460	552	48	217	103	145	159
LSE/LSN 180 LU	279	339	279	329	121	25	86	14.5	25	180	350	460	593	48	217	103	145	199
LSE/LSN 200 LT	318	378	305	365	133	30	108	18.5	30	200	350	480	599	54	217	103	145	167
LSE/LSN 200 L	318	388	305	375	133	35	103	18.5	36	200	390	505	621	62	217	103	145	194
LSE/LSN 225 ST	356	431	286	386	149	50	127	18.5	36	225	390	525	627	68	217	103	145	203
LSE/LSN 225 SR	356	431	286	386	149	50	127	18.5	36	225	390	525	676	68	217	103	145	253
LSE/LSN 225 MT	356	431	311	386	149	50	127	18.5	36	225	390	525	627	68	217	103	145	178
LSE/LSN 225 MR	356	431	311	386	149	50	127	18.5	36	225	390	525	676	68	217	103	145	228
LSE/LSN 225 MG	356	420	311	375	149	30	65	18.5	30	225	479	629	810	68	292	148	180	360
LSE/LSN 250 MZ	406	470	349	449	168	70	150	24	47	250	390	550	676	68	217	103	145	171
LSE/LSN 250 ME	406	470	349	420	168	35	90	24	36	250	479	655	810	68	292	148	180	303
LSE/LSN 250 MF	406	470	349	420	168	35	90	24	36	250	479	655	870	68	292	148	180	363
LSE/LSN 280 SC	457	520	368	478	190	35	90	24	35	280	479	685	810	68	292	148	180	262
LSE/LSN 280 SD	457	520	368	478	190	35	90	24	35	280	479	685	870	68	292	148	180	322
LSE/LSN 280 MC	457	520	419	478	190	35	90	24	35	280	479	685	810	68	292	148	180	211
LSE/LSN 280 MD	457	520	419	478	190	35	90	24	35	280	479	685	870	68	292	148	180	271

\* Dimensions not including cable gland

# TEFV induction motors - Aluminium frame

## LSE increased safety - LSN non-sparking

### Dimensions



## G3.3 - Foot and flange mounted IM B35 (IM 2001)

Dimensions in millimetres

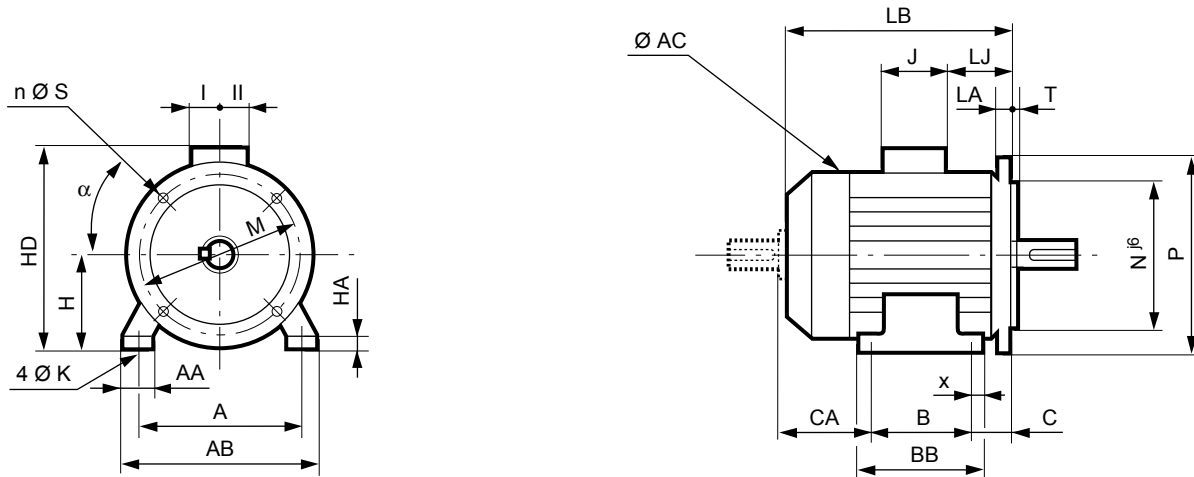

Type	Main dimensions																		
	A	AB	B	BB	C	X	AA	K	HA	H	AC	HD	LB	LJ	J	I	II*	CA	Symbol
LSE/LSN 80 L	125	157	100	120	50	10	29	9	10	80	170	227	215	7	124	62	62	68	FF 165
LSE/LSN 90 S	140	172	100	120	56	10	37	10	11	90	190	247	218	7	124	62	62	66	FF 165
LSE/LSN 90 SL/L	140	172	125	162	56	28	37	10	11	90	190	247	245	7	124	62	62	68	FF 165
LSE/LSN 100 L	160	196	140	165	63	12	40	12	13	100	200	262	290	7	124	62	62	93	FF 215
LSE/LSN 112 M	190	220	140	165	70	12	45	12	14	112	200	274	290	16	124	62	62	86	FF 215
LSE/LSN 112 MG	190	220	140	165	70	12	52	12	14	112	235	284	315	16	124	62	62	110	FF 215
LSE/LSN 112 MU	190	220	140	165	70	12	52	12	14	112	235	284	334	16	124	62	62	130	FF 215
LSE/LSN 132 S	216	250	140	170	89	16	50	12	15	132	235	304	350	33	124	62	62	128	FF 265
LSE/LSN 132 SM/M	216	250	178	208	89	16	59	12	18	132	280	331	387	17	124	62	62	126	FF 266
LSE/LSN 132 MU	216	250	178	208	89	16	59	12	18	132	280	331	410	17	124	62	62	148	FF 265
LSE/LSN 160 MP	254	294	210	294	108	20	64	14.5	25	160	315	361	468	48.5	124	62	62	154	FF 300
LSE/LSN 160 M	254	294	210	294	108	20	60	14.5	25	160	316	409	495	54.8	205	115	98	182	FF 300
LSE/LSN 160 LR	254	294	254	294	108	20	64	14.5	25	160	315	361	495	48.5	124	62	62	138	FF 300
LSE/LSN 160 L	254	294	254	294	108	20	60	14.5	25	160	316	409	495	54.8	205	115	98	138	FF 300
LSE/LSN 180 MT	279	324	241	316	121	20	79	14.5	28	180	316	453	495	39.2	217	103	145	138	FF 300
LSE/LSN 180 LR	279	324	279	316	121	20	79	14.5	28	180	316	460	520	39.2	217	103	145	125	FF 300
LSE/LSN 180 L	279	339	279	329	121	25	86	14.5	25	180	350	460	552	48	217	103	145	159	FF 300
LSE/LSN 180 LU	279	339	279	329	121	25	86	14.5	25	180	350	460	593	48	217	103	145	199	FF 300
LSE/LSN 200 LT	318	378	305	365	133	30	108	18.5	30	200	350	480	599	54	217	103	145	167	FF 350
LSE/LSN 200 L	318	388	305	375	133	35	103	18.5	36	200	390	505	621	62	217	103	145	194	FF 350
LSE/LSN 225 ST	356	431	286	386	149	50	127	18.5	36	225	390	525	627	68	217	103	145	203	FF 400
LSE/LSN 225 SR	356	431	286	386	149	50	127	18.5	36	225	390	525	676	68	217	103	145	253	FF 400
LSE/LSN 225 MT	356	431	311	386	149	50	127	18.5	36	225	390	525	627	68	217	103	145	178	FF 400
LSE/LSN 225 MR	356	431	311	386	149	50	127	18.5	36	225	390	525	676	68	217	103	145	228	FF 400
LSE/LSN 225 MG	356	420	311	375	149	30	65	18.5	30	225	479	629	810	68	292	148	180	360	FF 400
LSE/LSN 250 MZ	406	470	349	449	168	70	150	24	47	250	390	550	676	68	217	103	145	171	FF 500
LSE/LSN 250 ME	406	470	349	420	168	35	90	24	36	250	479	655	810	68	292	148	180	303	FF 500
LSE/LSN 250 MF	406	470	349	420	168	35	90	24	36	250	479	655	870	68	292	148	180	363	FF 500
LSE/LSN 280 SC	457	520	368	478	190	35	90	24	35	280	479	685	810	68	292	148	180	262	FF 500
LSE/LSN 280 SD	457	520	368	478	190	35	90	24	35	280	479	685	870	68	292	148	180	322	FF 500
LSE/LSN 280 MC	457	520	419	478	190	35	90	24	35	280	479	685	810	68	292	148	180	211	FF 500
LSE/LSN 280 MD	457	520	419	478	190	35	90	24	35	280	479	685	870	68	292	148	180	271	FF 500

\* Dimensions not including cable gland

# TEFV induction motors - Aluminium frame

## LSE increased safety - LSN non-sparking

### Dimensions



## G3.4 - Flange mounted IM B5 (IM 3001)

Dimensions in millimetres

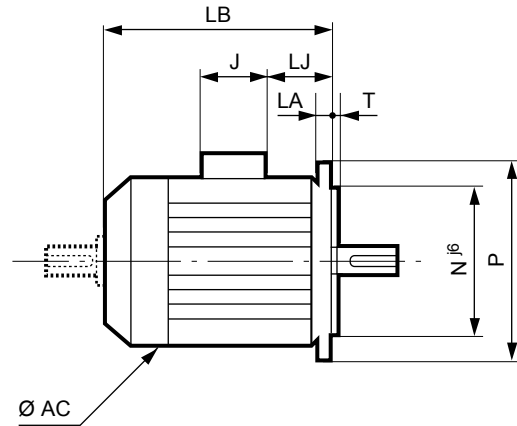
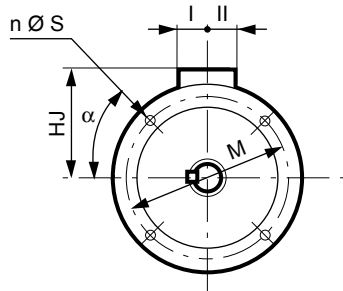

IEC symbol	Flange dimensions							
	M	N	P	T	n	$\alpha^\circ$	S	LA
FF 165	165	130	200	3.5	4	45	12	10
FF 165	165	130	200	3.5	4	45	12	10
FF 215	215	180	250	4	4	45	14.5	12
FF 215	215	180	250	4	4	45	14.5	12
FF 215	215	180	250	4	4	45	14.5	11
FF 265	265	230	300	4	4	45	14.5	12
FF 266	265	230	300	4	4	45	14.5	12
FF 265	265	230	300	4	4	45	14.5	12
FF 300	300	250	350	5	4	45	18.5	14
FF 300	300	250	350	5	4	45	18.5	14
FF 300	300	250	350	5	4	45	18.5	14
FF 300	300	250	350	5	4	45	18.5	14
FF 300	300	250	350	5	4	45	18.5	14
FF 300	300	250	350	5	4	45	18.5	14
FF 300	300	250	350	5	4	45	18.5	14
FF 350	350	300	400	5	4	45	18.5	15
FF 350	350	300	400	5	4	45	18.5	15
FF 400	400	350	450	5	8	22.5	18.5	16
FF 400	400	350	450	5	8	22.5	18.5	16
FF 400	400	350	450	5	8	22.5	18.5	16
FF 400	400	350	450	5	8	22.5	18.5	16
FF 400	400	350	450	5	8	22.5	18.5	16
FF 500	500	450	550	5	8	22.5	18.5	18
FF 500	500	450	550	5	8	22.5	18.5	18
FF 500	500	450	550	5	8	22.5	18.5	18
FF 500	500	450	550	5	8	22.5	18.5	18
FF 500	500	450	550	5	8	22.5	18.5	18
FF 500	500	450	550	5	8	22.5	18.5	18
FF 500	500	450	550	5	8	22.5	18.5	18
FF 500	500	450	550	5	8	22.5	18.5	18

Type	Main dimensions						
	AC	LB	HJ	LJ	J	I	II*
LSE/LSN 80 L	170	215	147	7	124	62	62
LSE/LSN 90 S	190	218	157	7	124	62	62
LSE/LSN 90 SL/L	190	245	157	7	124	62	62
LSE/LSN 100 L	200	290	162	7	124	62	62
LSE/LSN 112 M	200	290	162	16	124	62	62
LSE/LSN 112 MG	235	315	172	16	124	62	62
LSE/LSN 112 MU	235	334	172	16	124	62	62
LSE/LSN 132 S	235	350	172	33	124	62	62
LSE/LSN 132 SM/M	280	387	199	17	124	62	62
LSE/LSN 132 MU	280	410	199	17	124	62	62
LSE/LSN 160 MP	315	468	201	48.5	124	62	62
LSE/LSN 160 M	316	495	249	54.8	205	115	98
LSE/LSN 160 LR	315	495	201	48.5	124	62	62
LSE/LSN 160 L	316	495	249	54.8	205	115	98
LSE/LSN 180 MT	316	495	273	39.2	217	103	145
LSE/LSN 180 LR	316	520	280	39.2	217	103	145
LSE/LSN 180 L	350	552	280	48	217	103	145
LSE/LSN 180 LU	350	593	280	48	217	103	145
LSE/LSN 200 LT	350	599	280	54	217	103	145
LSE/LSN 200 L	390	621	305	62	217	103	145
LSE/LSN 225 ST	390	627	300	68	217	103	145
LSE/LSN 225 SR	390	676	300	68	217	103	145
LSE/LSN 225 MT	390	627	300	68	217	103	145
LSE/LSN 225 MR	390	676	300	68	217	103	145
LSE/LSN 225 MG	479	810	404	68	292	148	180
LSE/LSN 250 MZ	390	676	300	68	217	103	145
LSE/LSN 250 ME	479	810	405	68	292	148	180
LSE/LSN 250 MF	479	870	405	68	292	148	180
LSE/LSN 280 SC	479	810	405	68	292	148	180
LSE/LSN 280 SD	479	870	405	68	292	148	180
LSE/LSN 280 MC	479	810	405	68	292	148	180
LSE/LSN 280 MD	479	870	405	68	292	148	180

\* Dimensions not including cable gland

For a frame size  $\geq 250$  mm for IM 3001 use, please consult Leroy Somer.

Dimensions of shaft extensions identical to those for foot mounted motors.

# TEFV induction motors - Aluminium frame

## LSE increased safety - LSN non-sparking

### Dimensions



## G3.5 - Foot and face mounted IM B34 (IM 2101)

Dimensions in millimetres

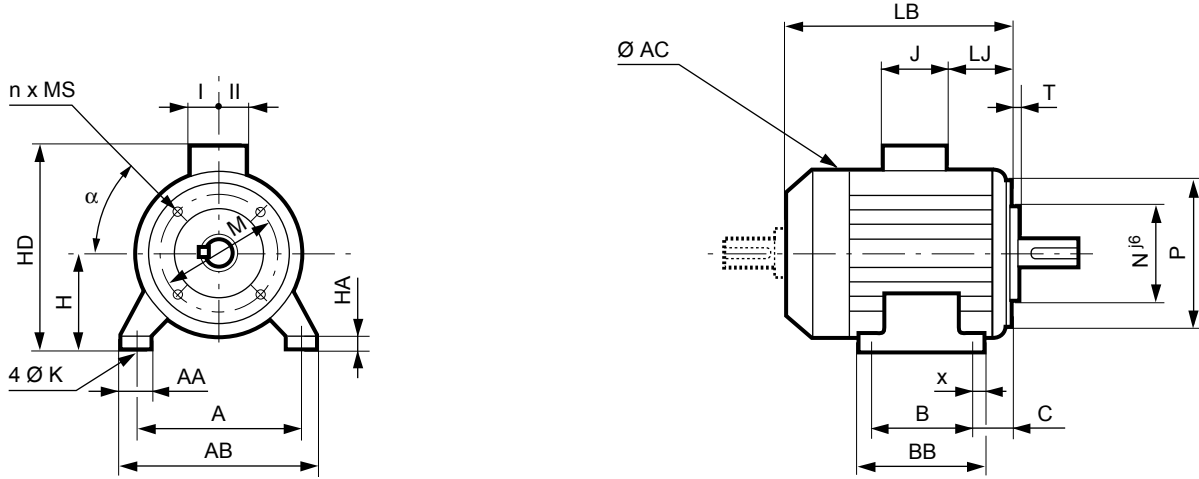

Type	Main dimensions																		
	A	AB	B	BB	C	X	AA	K	HA	H	AC	HD	LB	LJ	J	I	II*	CA	Symbol
LSE/LSN 80 L	125	157	100	120	50	10	29	9	10	80	170	227	215	7	124	62	62	68	FT 100
LSE/LSN 90 S	140	172	100	120	56	10	37	10	11	90	190	247	218	7	124	62	62	66	FT 115
LSE/LSN 90 SL/L	140	172	125	162	56	28	37	10	11	90	190	247	245	7	124	62	62	68	FT 115
LSE/LSN 100 L	160	196	140	165	63	12	40	12	13	100	200	262	290	7	124	62	62	93	FT 130
LSE/LSN 112 M	190	220	140	165	70	12	45	12	14	112	200	274	290	16	124	62	62	86	FT 130
LSE/LSN 112 MG	190	220	140	165	70	12	52	12	14	112	235	284	315	16	124	62	62	110	FT 130
LSE/LSN 112 MU	190	220	140	165	70	12	52	12	14	112	235	284	334	16	124	62	62	130	FT 130
LSE/LSN 132 S	216	250	140	170	89	16	50	12	15	132	235	304	350	33	124	62	62	128	FT 215
LSE/LSN 132 SM/M	216	250	178	208	89	16	59	12	18	132	280	331	387	17	124	62	62	126	FT 215
LSE/LSN 132 MU	216	250	178	208	89	16	59	12	18	132	280	331	410	17	124	62	62	148	FT 215
LSE/LSN 160 MP	254	294	210	294	108	20	64	14.5	25	160	315	361	468	48.5	124	62	62	154	FT 215
LSE/LSN 160 LR	254	294	254	294	108	20	64	14.5	25	160	315	361	495	48.5	124	62	62	138	FT 215

\* Dimensions not including cable gland

# TEFV induction motors - Aluminium frame

## LSE increased safety - LSN non-sparking

### Dimensions



## G3.6 - Face mounted IM B14 (IM 3601)

Dimensions in millimetres

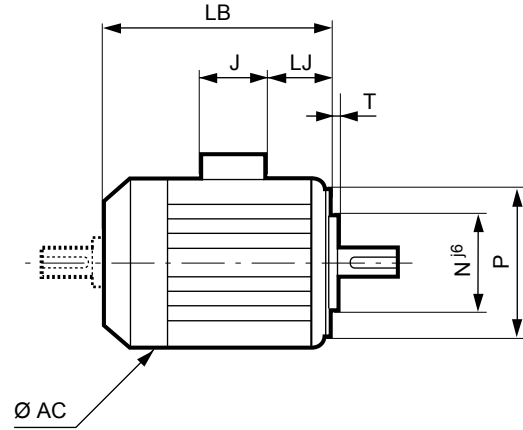
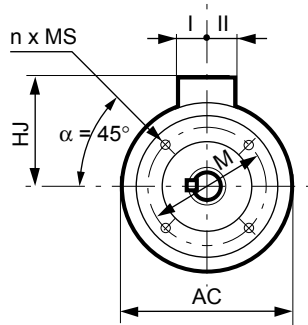

IEC symbol	Faceplate dimensions					
	M	N	P	T	n	MS
FT 100	65	50	80	2.5	4	M5
FT 115	75	60	90	2.5	4	M5
FT 115	85	70	105	2.5	4	M6
FT 130	100	80	120	3	4	M6
FT 130	100	80	120	3	4	M6
FT 130	115	95	140	3	4	M8
FT 130	115	95	140	3	4	M8
FT 215	115	95	140	3	4	M8
FT 215	130	110	160	3.5	4	M8
FT 215	130	110	160	3.5	4	M8
FT 215	130	110	160	3.5	4	M8
	215	180	250	4	4	M12

Type	Main dimensions						
	AC	LB	HJ	LJ	J	I	II*
LSE/LSN 80 L	170	215	147	7	124	62	62
LSE/LSN 90 S	190	218	157	7	124	62	62
LSE/LSN 90 SL/L	190	245	157	7	124	62	62
LSE/LSN 100 L	200	290	162	7	124	62	62
LSE/LSN 112 M	200	290	162	16	124	62	62
LSE/LSN 112 MG	235	315	172	16	124	62	62
LSE/LSN 112 MU	235	334	172	16	124	62	62
LSE/LSN 132 S	235	350	172	33	124	62	62
LSE/LSN 132 SM/M	280	387	199	17	124	62	62
LSE/LSN 132 MU	280	410	199	17	124	62	62
LSE/LSN 160 MP	315	468	201	48.5	124	62	62
LSE/LSN 160 LR	315	495	201	48.5	124	62	62

\* Dimensions not including cable gland

# 3-phase TEFV induction motors ATEX GAS - Zones 1 & 2 Optional features



## H1 - Electrical options



### H1.1 - THERMAL PROTECTION

These protection devices provide total protection of the motor against non-transient overloads. If a shorter reaction time is required, if you want to detect transient

overloads, or if you wish to monitor temperature rises at "hot spots" in the motor or at strategic points in the installation for maintenance purposes, it is advisable to install heat sensors at sensitive points. The various types are shown in the table below,

with a description of each. It must be emphasized that under no circumstances can these sensors be used to carry out direct regulation of the motor operating cycles.

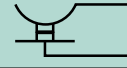
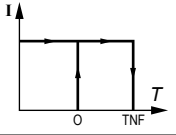
#### Built-in indirect thermal protection

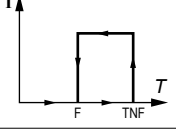
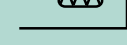
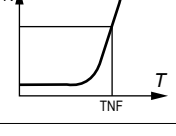
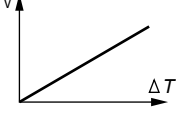
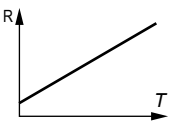
Type	Operating principle	Operating curve	Cut-off	Protection provided	Mounting Number of devices*
Normally closed thermal protection (closed when de-energized) <b>PTO**</b>	Bimetallic strip, indirectly heated, with normally closed (NC) contact 		2.5 A at 250 V with Cos $\varphi$ 0.4	General surveillance for non-transient overloads	Mounted in control circuit 2 or 3 in series
Normally open thermal protection (open when de-energized) <b>PTF**</b>	Bimetallic strip, indirectly heated, with normally open (NO) contact 		2.5 A at 250 V with Cos $\varphi$ 0.4	General surveillance for non-transient overloads	Mounted in control circuit 2 or 3 in parallel
Positive temperature coefficient thermistor <b>PTC</b>	Variable non-linear resistance with indirect heating 		0	General surveillance for transient overloads	Mounted with associated relay in control circuit 3 in series
Thermocouples <b>T</b> ( $T < 150^{\circ}\text{C}$ ) Copper Constantan <b>K</b> ( $T < 1000^{\circ}\text{C}$ ) Copper-nickel	Peltier effect		0	Continuous surveillance of hot spots at regular intervals	Mounted in control panels with associated reading equipment (or recorder) 1 per hot spot
Platinum resistance thermometer <b>PT 100</b>	Variable linear resistor with indirect heating		0	High accuracy continuous surveillance of key hot spots	Mounted in control panels with associated reading equipment (or recorder) 1 per hot spot

\* The number of devices relates to the winding protection.

\*\* Only on FLSD motors

- NRT: nominal running temperature

- The NRTs are chosen according to the position of the sensor in the motor and the temperature class.

#### Fitting thermal protection

- PTO or PTF, in the control circuits

- PTC, with relay, in the control circuits

- PT 100 or Thermocouples, with reading equipment or recorder, in the control panel of the installation for continuous surveillance

#### Alarm and safety

All protective equipment can be backed up by another type of protection (with different NRTs): The first device will then act as an alarm (light or sound signals given without shutting down the power circuits), and the second device will be the safety system (shutting down the power circuits).

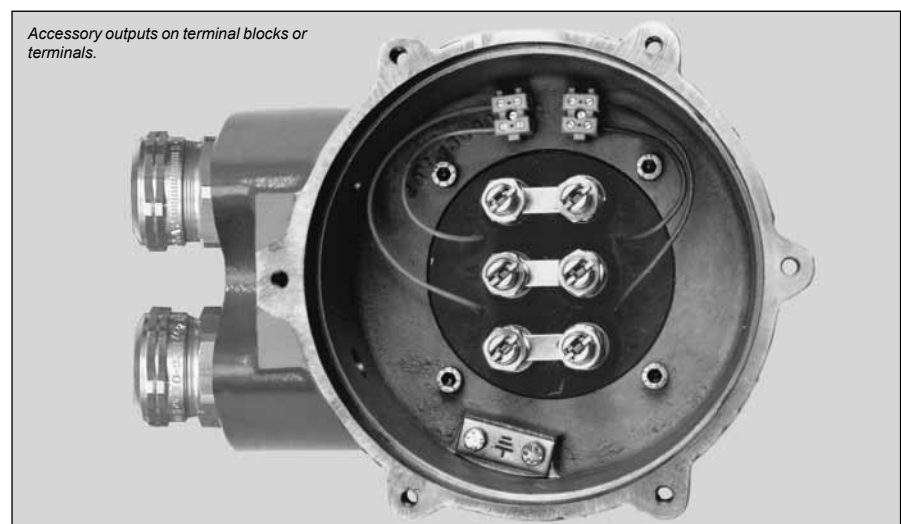

# 3-phase TEFV induction motors ATEX GAS - Zones 1 & 2 Optional features



## H2 - Mechanical options

### H2.1 - TERMINAL BOX

Dimensions in millimetres

#### H2.1.1 - Optional "e" increased safety terminal boxes

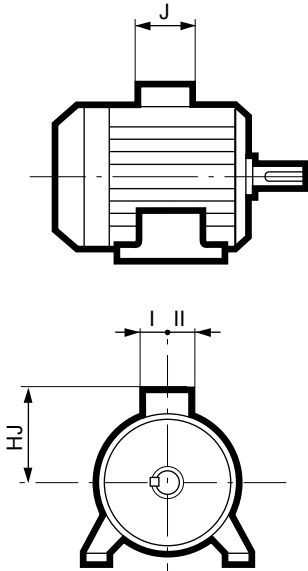

Type	J	HJ	I	II
FLSD 80	158	196	79	79
FLSD 90 and 100	158	206	79	79
FLSD 112	158	218	79	79
FLSD 132	158	230	79	79
FLSD 160 and 180	223	311	113	156
FLSD 200 and 225	223	346	113	156
FLSD 250	360	470	208	205
FLSD 280	330	488	165	271
FLSD 315 S/M/L	452	540	220	269
FLSD 355	452	575	220	269

#### H2.1.2 - Auxiliary terminal boxes

All ATEX motors with frame size  $\geq 160$  mm can be fitted with one or two type "e" auxiliary terminal boxes to take the terminal blocks for connecting electrical options such as heat sensors and/or the heating resistor. These auxiliary terminal boxes are fixed on the body of the main terminal box.

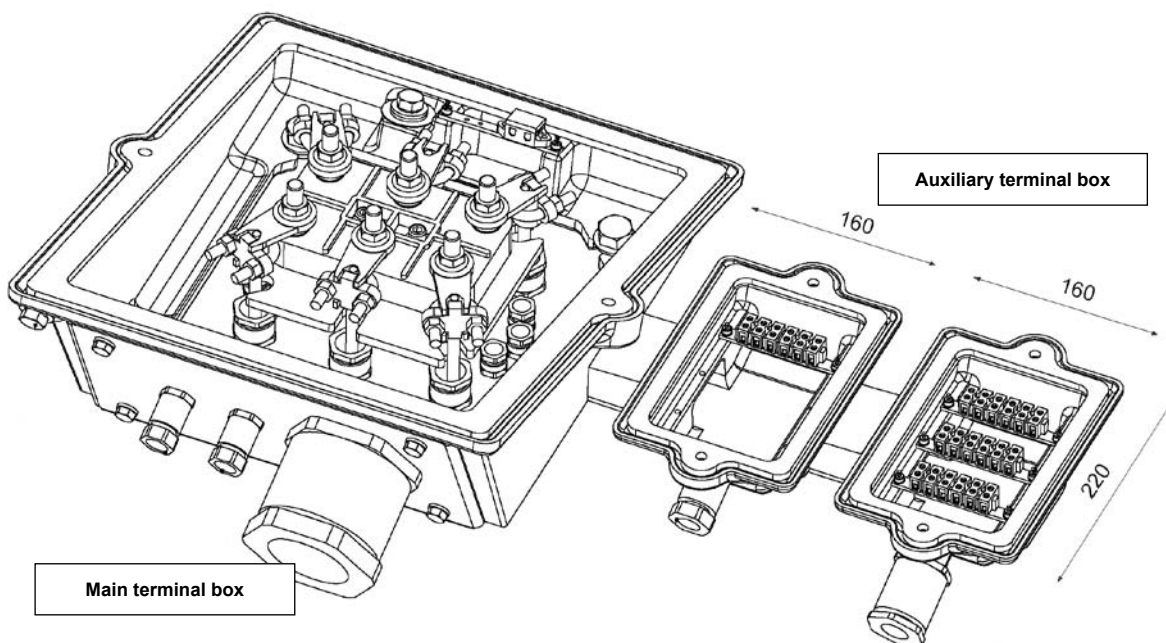

# 3-phase TEFV induction motors ATEX GAS - Zones 1 & 2 Optional features



## H2 - Mechanical options

### H2.2 - VIBRATION SENSOR ADAPTATION

On request, our motors can be fitted with tapped holes (for SPM type sensor) on faceplates, to take the vibration sensors (not supplied).

The adaptors form a connection with the snap-on transmitter.

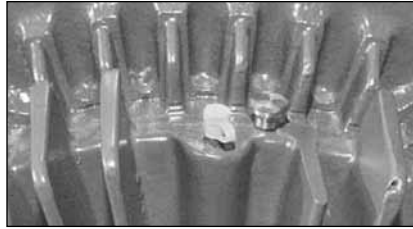

### H2.3 - DRAINING CONDENSATION WATER

To drain off any moisture that may have accumulated inside during cooling of the machine, drain holes are provided at the lowest points of the enclosure, depending on the operating position (IM etc). The holes may be sealed in various ways:

- standard: with plugs
- on request: with screws or siphon

Opening the holes periodically should be part of the regular maintenance procedure.

Being specially designed for harsh environments, they are fitted with a PVC seal after undergoing the following surface treatments:

- 1 - zinc: 15 µm Zn
- 2 - silver for very corrosive environments:  
2 µm Cu + 30 µm Ag

Frame size	Non-sparking LSN/FLSN	Increased safety LSE/FLSE	Flameproof FLSD
80 to 132 mm	●	●	-
160 to 200 mm	●	●	○
250 mm and above	●	●	○

● available ○ please consult Leroy-Somer

### H2.4 - TAPPED HOLES FOR POSITIONING

Tapped holes for positioning can be made on the motor feet in order to make it easier to adjust and align the motor.

They have a metric thread which can also be created to suit another standard diameter on request.

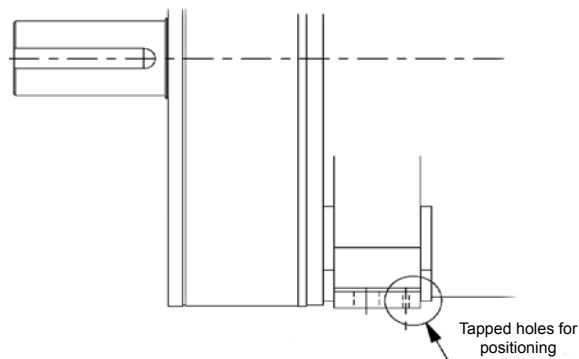

### H2.5 - RADIAL SEAL

When a motor needs to be mounted in the vertical position, shaft end facing up (position IM 1031, 2031 and 3031 for example) and its shaft end is not correctly protected by the driven machine against rain or water splashes, it is advisable to use an optional radial seal on the drive end to avoid water getting into the motor around the shaft.

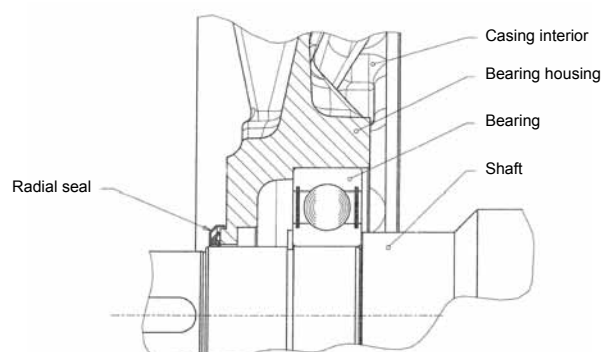

# 3-phase TEFV induction motors ATEX GAS - Zones 1 & 2 Optional features



## H2 - Mechanical options

### H2.6 - FORCED VENTILATION

The ATEX motors described in this catalogue are approved to be supplied with frequency inverters.

This type of application sometimes requires the mounting of a forced ventilation unit for use at low speed (temperature rise) or at high speed (noise), in addition to the thermal protection (winding and DE shield).

The mounting of an axial forced ventilation unit is recommended for motors  $\geq$  frame size 160.

**Safety conditions:** The forced ventilation unit is controlled by the power supply and should have the same degree of flameproof protection as the FLSD motor.

To adapt the motor to the application, it is necessary to inform the manufacturer of the operating characteristics (speed range, voltage, frequency, etc).

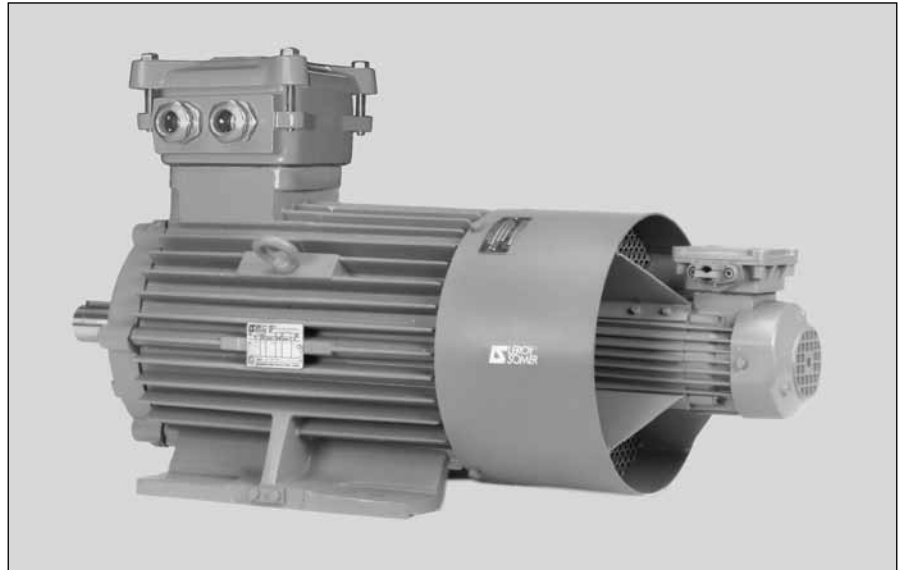

### H2.7 - ENCODERS

All our "d", "e" and "n" safety motors can be fitted with an ATEX-certified incremental encoder with a protection level  $\text{Ex} \text{ II } 2\text{GD} \text{ Ex d IIC}$ .

This pulse generator supplies a number of pulses proportional to the motor speed. It can be supplied with a D.C. voltage of 5 V +/- 10% or 11-30 V regulated.

The drive encoder lines per revolution should be specified (at the time of ordering): 1024 or 4096 (for the incremental encoder) and 8192 (for the absolute encoder).



### H2.8 - ROLLER BEARINGS

For high radial forces, it is possible to adapt roller bearings to the motor DE shield from frame size 160 upwards.

Please consult Leroy-Somer.

### H2.9 - FLYING LEADS

Motors can be fitted with flying leads consisting of multicore cables or single-core cables for high currents.

The earthing is included in the sheathed cable output.

Accessories (thermal protection, space heaters, etc) are usually connected using another multicore cable.

**Caution:** Motors with flying leads must be connected in an area with a protection type compatible with the installation zone.



# 3-phase TEFV induction motors ATEX GAS - Zones 1 & 2 Optional features



## H2 - Mechanical options

### H2.10 - NON-STANDARD FLANGES

Optionally, LEROY-SOMER motors can be fitted with flanges and faceplates that are larger or smaller than standard. This means that motors can be adapted to all types of situation without the need for costly and time-consuming modifications.

The tables below give the flange and faceplate dimensions and indicate flange/motor compatibility.

The bearing and shaft extension for each frame size remain standard.

#### MAIN FLANGE DIMENSIONS

##### (FF) Flange with clearance holes

Dimensions in millimetres

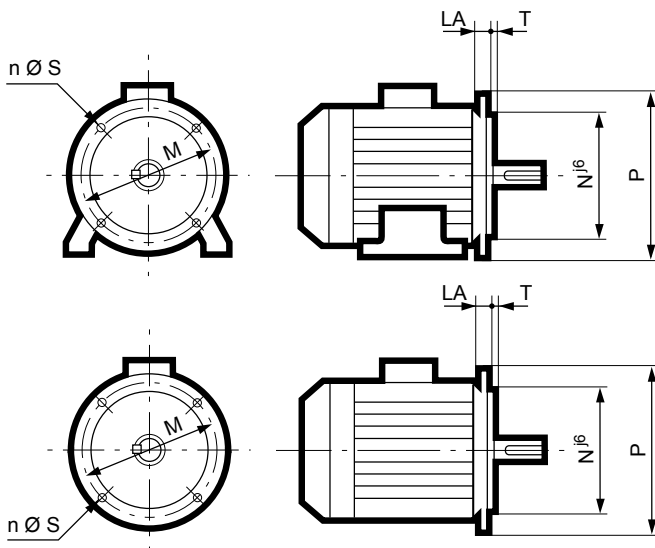

IEC symbol	Flange dimensions						
	M	N	P	T	n	S	LA
FF 115	115	95	140	3	4	10	10
FF 130	130	110	160	3.5	4	10	10
FF 165	165	130	200	3.5	4	12	10
FF 215	215	180	250	4	4	15	12
FF 265	265	230	300	4	4	15	14
FF 300	300	250	350	5	4	18	15
FF 350	350	300	400	5	4	18	15
FF 400	400	350	450	5	8	18	16
FF 500	500	450	550	5	8	18	18**
FF 600	600	550*	660	6	8	22	25
FF 740	740	680*	800	6	8	22	25
FF 940	940	880*	1000	6	8	28	28
FF 1080	1080	1000*	1150	6	8	28	30

\* Tolerance Njs<sup>6</sup> from FF 600 upwards

\*\* LA = 22 for frame size ≥ 280

##### (FT) Face with tapped holes

Dimensions in millimetres

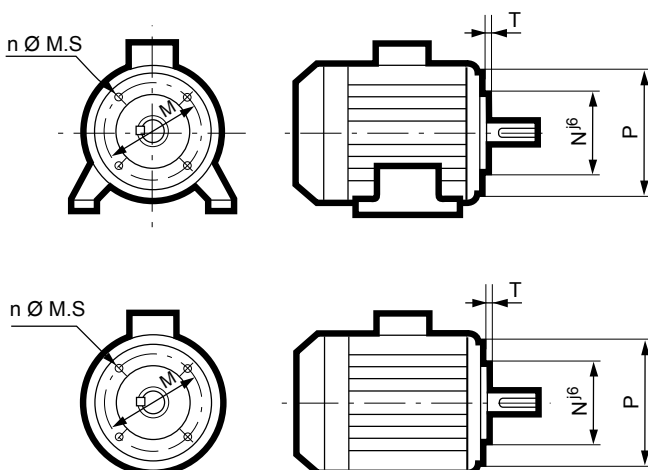

IEC symbol	Faceplate dimensions					
	M	N	P	T	n	M.S
FT 85	85	70	105	2.5	4	M6
FT 100	100	80	120	3	4	M6
FT 115	115	95	140	3	4	M8
FT 130	130	110	160	3.5	4	M8
FT 165	165	130	200	3.5	4	M10
FT 215	215	180	250	4	4	M12
FT 265	265	230	300	4	4	M12

# 3-phase TEFV induction motors

## ATEX GAS - Zones 1 & 2

### Optional features



## H2 - Mechanical options

### H2.10.1 - FLSD flameproof motors

Some FLSD motors can be fitted with faceplates with different dimensions from those specified by the IEC standard. The table below indicates the optional flanges available by motor type:

Flange type Motor type	(FF) Flange mounted				(FT) Face mounted				
	FF 130	FF 165	FF 215	FF 265	FT 100	FT 115	FT 130	FT 165	FT 215
FLSD 80	○	●			●				
FLSD 90	*	●				●			
FLSD 100		*	●				●		
FLSD 112		○	●				●		
FLSD 132				●				○	●

● standard    ○ modified bearing location    \* adaptable without modification

### H2.10.2 - LSE and LSN motors

The LSE and LSN ranges of motors with aluminium frame can be fitted with numerous flanges and faceplates with different dimensions from those specified by the IEC standard. The table below indicates the optional flanges available by motor type:

Flange type Motor type	(FF) Flange mounted											(FT) Face mounted									
	FF 100	FF 115	FF 130	FF 165	FF 215	FF 265	FF 300	FF 350	FF 400	FF 500	FF 600	FT 65	FT 75	FT 85	FT 100	FT 115	FT 130	FT 165	FT 215	FT 265	
LSE/LSN 56	●											●	*	*	*						
LSE/LSN 63	○	●	*									*	●	*	*	*					
LSE/LSN 71	○	○	●	○								*	*	●	*	*	*				
LSE/LSN 80		○	○	●	*									*	●	*	*	*			
LSE/LSN 90		*	*	●	*										*	●	*				
LSE/LSN 90 (Foot)		○	○	○	○										*	●	*	○			
LSE/LSN 100		○	○	○	●											*	●	*	*	*	
LSE/LSN 112 M		○	○	○	●											*	●	*	*	*	
LSE/LSN 112 MG			○	○	●	*										*	●	*	*	*	
LSE/LSN 132 S				○	*	●											*	*	●	*	
LSE/LSN 132 SM/M/MU				○	○	●	○											*	●	*	
LSE/LSN 160 MP/L/LR					*	*	●	*											●	*	
LSE/LSN 180							●	*													
LSE/LSN 200						*	●	*													
LSE/LSN 225								●	*												
LSE/LSN 250								*	●												
LSE/LSN 280									●	*											
LSE/LSN 315									*	●											

● standard    ○ modified bearing location    \* adaptable without modification    ■ : non-standard

# 3-phase TEFV induction motors ATEX GAS - Zones 1 & 2 Optional features



## H2 - Mechanical options

### H2.10.3 - FLSE and FLSN motors

The FLSE and FLSN ranges of motors with aluminium frame can be fitted with numerous flanges and faceplates with different dimensions from those specified by the IEC standard. The table below indicates the optional flanges available by motor type:

Flange type Motor type	(FF) Flange mounted												(FT) Face mounted								
	FF 115	FF 130	FF 165	FF 215	FF 265	FF 300	FF 350	FF 400	FF 500	FF 600	FF 740	FF 600	FF 740	FT 58	FT 100	FT 115	FT 130	FT 165	FT 215	FT 265	
FLSE/FLSN 80 L	○	○	●	*										*	●	*	*	*			
FLSE/FLSN 90	*	*	●	*											*	●	*	○			
FLSE/FLSN 90 (Foot)	○	○	○	○											*	●	*	○			
FLSE/FLSN 100 LK	○	○	○	●												*	●	○	*		
FLSE/FLSN 112 M	○	○	○	●												*	●	○	*		
FLSE/FLSN 112 MR		○	○	●	*											*	●	*	*		
FLSE/FLSN 132 S/M/MU			○	○	●	○												*	●	*	
FLSN 160 M/L				*	*	●	*														
FLSN 180 MR						●	*														
FLSN 180 L						●	*														
FLSN 200 L							●	*													
FLSN 225 ST/MT							*	●													
FLSN 225 S/M								●	*												
FLSN 250 M								*	●												
FLSN 280 S									●												
FLSN 280 M									●												
FLSN 315 S									*	●											
FLSN 315 M/L										●											
FLSN 355 L										○	●										
FLSN 355 LK											●	*									
FLSN 400											*	●									
FLSN 400 LK												●	*								
FLSE/FLSN 450												*	●								

● standard ○ modified bearing location \* adaptable without modification

# 3-phase TEFV induction motors ATEX GAS - Zones 1 & 2 Optional features



## H2 - Mechanical options

Dimensions in millimetres

### H2.11 - DRIP COVER H2.11.1 - FLSD motors

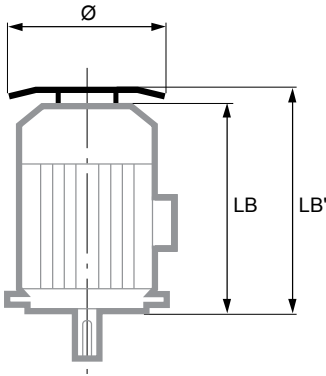

Drip cover for operation in vertical position outdoors, shaft end facing down.

Type	LB'	Ø
FLSD 80	LB + 22	145
FLSD 90 and 100	LB + 25	185
FLSD 112	LB + 25	208
FLSD 132	LB + 35	238
FLSD 160 and 180	LB + 65	298
FLS 200 and 225	LB + 70	298
FLSD 250 - 280 and 315	LB + 130	420
FLSD 355	LB + 135	500

### H2.11.2 - LSE - LSN motors

Type	LB'	Ø
LSE-LSN 80	LB + 20	145
LSE-LSN 90	LB + 20	185
LSE-LSN 100	LB + 20	185
LSE-LSN 112 M	LB + 20	185
LSE-LSN 112 MG	LB + 25	210
LSE-LSN 132 S	LB + 25	210
LSE-LSN 132 SM and M	LB + 30	240
LSE-LSN 160 MP-LR	LB + 30	240
LSE-LSN 160 M-L-LU	LB + 36.5	265
LSE-LSN 180 MT-LR	LB + 36.5	265
LSE-LSN 180 L/LU	LB + 36.5	305
LSE-LSN 200 LT	LB + 36.5	305
LSE-LSN 200 L-LU	LB + 36.5	350
LSE-LSN 225 ST-MT-MR	LB + 36.5	350
LSE-LSN 225 MG	LB + 55	420
LSE-LSN 250 MZ	LB + 36.5	350
LSE-LSN 250 ME-MF	LB + 55	420
LSE-LSN 280 SC/SD/MC/MD	LB + 55	420
LSE-LSN 280 SK-MK	LB + 76.5	505

### H2.11.3 - FLSE - FLSN motors

Type	LB'	Ø
FLSE-FLSN 80	LB + 20	145
FLSE-FLSN 90 and FLSE-FLSN 100	LB + 20	185
FLSE-FLSN 112 M	LB + 20	185
FLSE-FLSN 112 MU	LB + 25	210
FLSE-FLSN 132	LB + 30	240
FLSN 160 and FLSN 180 MR	LB + 60	320
FLSN 180 L	LB + 60	360
FLSN 200 L	LB + 75	400
FLS 225 ST/MT	LB + 75	400
FLSN 225 M and FLSN 250 M	LB + 130	420
FLSN 280 and FLSN 315	LB + 130	420
FLSN 355 L	LB + 135	500
FLSN 355 LK	LB + 160	650

**I - SCOPE OF APPLICATION**

These General Conditions of Sale («GCS») shall apply to the sale of all products, components, software and services (referred to as «Products») proposed or sold by the Seller to the Client. Said GCS shall also apply to all quotation or offers made by the Seller, and are an integral part of all orders. «Seller» is understood to mean all companies directly or indirectly controlled by LEROY-SOMER. As a complementary measure, orders are also subject to the latest version in force of the Inter-Union General Conditions of Sale for France of the F.I.E.E.C. (*Fédération des Industries Electriques, Electroniques et de Communication*) [Federation of Electrical, Electronic and Communication Industries], inasmuch as they are not contrary to the GCS.

The acceptance of the Seller's offers or quotations, or any order, entails the acceptance without reservation of these GCS and rules out all contrary provisions shown on all other documents and, in particular, on the Client's order forms and the Client's General Conditions of Purchase.

If the sale concerns castings, by way of derogation to Paragraph 1 above, said castings shall be subject to the latest version in force of the *Conditions Générales Contractuelles des Fonderies Européennes* [General Contractual Conditions of European Foundries].

**The Products and services sold pursuant to these GCS may under no circumstances be used for applications in the nuclear field, as such sales expressly fall under technical specifications and specific contracts that the Seller reserves the right to refuse.**

**II - ORDERS**

All orders, even those taken by the Seller's agents and representatives, and regardless of the transmission method, shall only bind the Seller after written acceptance thereby of the order.

The Seller reserves the option of modifying the characteristics of its Products without notice. However, the Client shall retain the possibility of specifying the characteristics on which its commitment is contingent. In the absence of any such express stipulation, the Client may not refuse delivery of new, modified Products.

The Seller may not be held liable for an unsatisfactory selection of Products if said selection results from conditions of use that are incomplete and/or mistaken, or not disclosed to the Seller by the Client. Except in the event of a stipulation to the contrary, the offers and quotations remitted by the Seller shall only be valid for thirty days as from the date on which they are drawn up.

Where the Products must comply with standards, specific regulations and/or be received by control and inspection agencies, the price request must be accompanied by the technical specification, all terms and conditions the Seller must comply with. Reference shall be made thereto on the quotation or offer. Approval and attendance costs shall always be borne by the Client.

**III - PRICES**

Tariffs are expressed exclusive of tax and may be revised without notice.

Prices are either deemed to be firm for the period of validity specified on the quotation, or subject to a revision formula attached to the offer and which specifies, according to the regulations, parameters pertaining to the materials, products, various services and salaries for which the indices are published in the B.O.C.C.R.F. (*Bulletin Officiel de la Concurrence, de la Consommation et de la Répression des Fraudes*) [French Official Journal of Competition and Consumer Matters, and Anti-Fraud Measures].

All additional costs, in particular approval costs, specific checks, etc., shall be invoiced in addition.

**IV - DELIVERY**

Sales are governed by the latest edition in force of the INCOTERMS published by the Internal Chamber of Commerce («I.C.C. INCOTERMS»).

The Products shall be dispatched according to the conditions stated on the order acknowledgement issued by the Seller for all orders of Products.

Except in the event of specific provisions, the prices correspond to Products that are made available in the Seller's factories, including basic packaging.

Except in the event of a provision to the contrary, the Products shall always be transported at the risk of the addressee. In all cases, it shall be the responsibility of the addressee to make any claims to the carrier, within the delivery time and in the forms specified by law, concerning the state or number of parcels received, and to concomitantly provide the Seller with a copy of such declaration. Failure to comply with said procedure shall exempt the Seller from any liability. In any event, the Seller's liability may not exceed the amount of the indemnities received from its insurers.

If the provisions concerning transportation are amended by the Client subsequent to the acceptance of the order, the Seller reserves the right to invoice any supplemental costs that may result therefrom. Except in the event of a contractual or statutory obligation to the contrary, packaging shall not be returnable.

In the event that a delivery of Products is delayed for a reason not attributable to the Seller, the Products stored on the Seller's premises shall be insured at the exclusive risk of the Client. Consideration for storage, costs will be invoiced at a rate of 1% (*one per cent*) of the total amount of the order, per week or partial week of storage, with no deductible or *de minimis* amount, as from the date of Products availability provided for in the contract. Upon expiration of a period of thirty days as from said date, the Seller may, at its discretion, either freely dispose of the Products and/or agree with the Client on a new delivery date for said Products, or invoice the Client in full for payment, according to the timeframes and amount provided for contractually. In any event, down payments shall inure to the Seller as indemnities, without prejudice to any other action the Seller may take.

**V - DELIVERY TIME**

The Seller shall only be bound by the delivery time mentioned on its order acknowledgement. Said delivery time shall only start to run as from the date of issuance of the order acknowledgement by the Seller, and subject to the fulfillment of the conditions provided for on the confirmation receipt, in particular receipt of the down payment for the order, notification of the opening of an operative irrevocable and confirmed documentary credit that complies in all respects to the Seller's request (*in particular regarding the amount, currency, validity and licence*), acceptance of the payment conditions accompanied by the implementation of any guarantees requested, etc.

Exceeding delivery time shall not grant the Client entitlement to damages and/or penalties.

Except in the event of a specific condition to the contrary, the Seller reserves the right to make partial deliveries. Delivery times shall be interrupted by right and without the need for any judicial formalities, by any failure to pay or late payment by the Client.

**VI - TESTS - QUALIFICATION**

The Products manufactured by the Seller are checked and tested before leaving its factories. Clients may be present at said tests if specified on the order.

Specific tests and/or trials, as well as approval of Products, requested by the Client, whether carried out on the Client's premises or in the Seller's factories, on site, or by control and inspection agencies, must be specified on the order and are always at Client's expense.

Prototypes for Products specially developed or adapted for a Client must be qualified by the Client before serial production in order to ensure that it is compatible with the other components that make up its equipment, and that it is adapted to the intended use. Said qualification will also enable the Client to ensure that the Products comply with the technical specification. In this respect, the Client and Seller shall sign a Product Approval Form in two original, one of which shall be retained by the Client and one by the Seller.

In the event that the Client requires delivery without having firstly qualified the Products, said Products shall be delivered as they stand and shall always be deemed to be prototypes; the Client shall then be solely liable for using the Products or delivering them to its own clients. However, the Seller may also decide not to deliver the Products that have not received the Client's prior approval.

**VII - PAYMENT CONDITIONS**

All sales shall be deemed to be completed and payable at the Seller's registered office, without any possible derogation, regardless of the payment method, where the contract was concluded and where delivery was made.

Where the Client is located out of French territory, invoices shall be payable in cash upon receipt, or by a bank draft or a bill of exchange, within 30 (thirty) days net.

All early payment compared to the deadline fixed shall give right to a discount of 0.2% (*nought point two per cent*) per month, of the amount concerned of the invoice.

Except in the event of provisions to the contrary, where the Client is located outside of French Territory, invoices shall be payable in cash againstremittance of shipping documents, or by irrevocable documentary credit confirmed by a first rate French bank, at Client's expense.

Payment shall be understood to mean the funds being made available on the Seller's bank account and must imperatively be made in the invoicing currency.

Pursuant to French Law no. 2008-776 of 4 August 2008, failure to pay an invoice when due shall trigger, after service of formal notice that has remained without effect, payment to the Seller of a flat-rate penalty on the due date of the receivable, which shall be applied to amount inclusive of tax of monies owed if the invoice is liable to VAT (*Value Added Tax*), and the suspension of pending orders. Said penalty is equal to the European Central Bank interest rate on the main refinancing operations + 10 basis points.

The collection of said monies via litigation shall trigger an increase of 15% (*fifteen per cent*) of the amount claimed, with a minimum of Euros 500 exclusive of tax (*five hundred euros exclusive of tax*), with tax in addition if due.

Moreover, subject to compliance with the statutory provisions in force, in the event of total or partial failure to pay any invoice or instalment whatsoever, regardless of the payment method used, all amounts that remain owed to the Seller (*including its subsidiaries, affiliated or allied companies, whether French or foreign*) for all deliveries and services, regardless of the due date originally provided for, shall immediately become due.

Notwithstanding any specific payment conditions provided for between the parties, the Seller reserves the right to require, in the event of a decline in the Client's credit rating, a payment incident or bankruptcy of the Client:

- the payment in cash, before the Products leave the factory, for all orders currently being fulfilled,
- down payments to be made on all orders,
- alternative or different payment guarantees.

**VIII - PAYABLE AND RECEIVABLE BALANCE**

Except where prohibited by law, the Seller and the Client expressly agree to balance their payables and receivables arising from their trade relations, even if all conditions defined by law for legal balancing are not met.

For the application of said clause, the Seller shall mean any company of the LEROY-SOMER Group.

**IX - TRANSFER OF RISK / RESERVE OF TITLE**

**Risk shall be transferred as soon as the Products are made available, according to the delivery conditions stipulated on the order acknowledgement.**

**The transfer to the Client of title shall take place after payment in full. In the event that the restitution of the Products delivered is claimed by the Seller, the Seller is entitled to retain any down payment as compensation.**

**Remittance of a bill that creates an obligation to pay (*bill of exchange or other*) shall not constitute payment and discharge. For as long as the price has not been paid in full, the Client is required to inform the Seller, within twenty-four hours, of the sequestration, requisition or confiscation of the Products for the benefit of a third party, and to take all protective measures to make known the Seller's property right in the event of action by creditors, and to cause such right to be respected.**

**X - CONFIDENTIALITY**

Each of the parties undertakes to maintain the confidentiality of all technical, trade, financial or other information received from the other party, whether orally, in writing or by any other means of communication, when any order is negotiated and/or fulfilled.

This confidentiality obligation shall apply throughout the period during which the order is fulfilled and for 5 (five) years subsequent to completion or cancellation thereof, regardless of the reasons therefor.

**XI - INDUSTRIAL AND INTELLECTUAL PROPERTY**

Data, studies, results, information or software, whether patentable or not obtained by the Seller when any order is fulfilled shall remain the exclusive property of the Seller.

With the exception of instruction and maintenance manuals, documents of any nature remitted to the Client shall remain the exclusive property of the Seller and must be returned to it upon request, even if the Client was invoiced for part of the cost of the study, and said documents may not be disclosed to third parties or used without the Seller's prior written agreement.

**XII - CANCELLATION / TERMINATION**

The Seller reserves the right to cancel or terminate immediately, at the Seller's discretion, by right and without the need for any judicial formalities, the contract in the event of failure to pay any portion whatsoever of the price, when due, or in the event of any breach of any of the Client's contractual obligations. Down payments and any amount already paid shall remain in Seller's hands in the form of indemnities, without prejudice to the Seller's right to claim damages. In the event that the contract is cancelled, the Products must be returned to the Seller immediately, regardless of where the Products are located, at Client's expense and risk, under penalty of 10% (*ten per cent*) of the value thereof, per week's delay.

**XIII - WARRANTY**

The Seller warrants the Products against all operating defects caused by a material or manufacturing fault, for a period of twelve months as from the date on which the Products are made available, unless a different statutory provision subsequently applies, under the conditions defined below.

The warranty may only be triggered insofar as the Products have been stored, used and maintained in accordance with the Seller's instructions and manuals. The warranty does not apply where the defect results, in particular, from:

- inadequate monitoring, maintenance or storage,
- normal wear and tear on the Products,
- servicing or modification of the Products without the Seller's prior written authorisation,
- abnormal use of the Products or use of the Products for a purpose other than that intended,
- faulty installation of the Products on the premises of the Client and/or the end user,
- failure by the Client to disclose the purpose or conditions of use of the Products,
- failure to use genuine spare parts,
- force majeure or any event that is beyond the control of the Seller.

In any case, the warranty is limited to the replacement or repair of the parts or Products deemed faulty by the Seller's technical departments. If the repair is entrusted to a third party, the repair shall only be carried out once the Seller has agreed to the quotation for the repair.

All Products returns must have been given the Seller's prior, written authorisation.

The Products to be repaired must be dispatched carriage paid, to the address given by the Seller. If the Products are not accepted under warranty, their return to the Client shall be invoiced to the Client or the end user.

This warranty shall apply to the Seller's Products that are made readily available and therefore does not cover the de-installation and re-installation of said Products in the equipment into which it is mounted. Repair, modification or replacement of any part or Product during the warranty period may not result in the warranty period being extended.

The provisions of this article constitute the Seller's sole obligation concerning the warranty of the Products delivered.

**XIV - LIABILITY**

The Seller's liability is strictly limited to the obligations stipulated in these GCS and those expressly accepted by the Seller. All penalties and indemnities provided for therein constitute lump sum damages that include discharge for the Seller and are exclusive of any other penalty or indemnification.

With the exception of the Seller's gross negligence and the compensation of bodily injury, the Seller's liability shall be limited, in total, to the contractual amount, exclusive of tax, of the Product(s) that give(s) right to compensation.

The Seller may under no circumstances be required to indemnify consequential, indirect and / or punitive damages that the Client may use as the basis for a claim; as a result, the Seller may not be required to indemnify, in particular, production losses, operating losses or lost profit or, in general, any damage eligible for indemnification other than bodily injury or damage to property.

The Client undertakes to hold harmless the Seller and / or its insurers from any and all claims made by its insurers and/or any third party in a contractual relation with the Client, in excess of the limit and for the exclusions listed above.

**XV - SPARE PARTS AND ACCESSORIES**

Spare parts and accessories shall be supplied upon request, to the extent of their availability. Associated costs shall be invoiced in addition. The Seller reserves the right to require a minimum quantity or invoicing amount per order.

**XVI - WASTE MANAGEMENT**

The Products that form the purpose of the sale does not fall within the scope of the European Directive 2002/96/EC (WEEE) dated January 27<sup>th</sup>, 2003, and all related legislation of Member States of the European Union that result therefrom, on the composition of electrical and electronic equipment and the disposal of waste from such equipment.

In accordance with Article L541-2 of the French Environment Code, it is the responsibility of the waste holder to ensure the disposal thereof or to cause the disposal thereof at its own expense.

**XVII - FORCE MAJEURE**

With the exception of the Client's obligation to pay the monies owed to the Seller in respect of an order, the Client and Seller may not be held liable for the total or partial failure to perform their contractual obligations if such failure results from the occurrence of a force majeure. Delays or disturbances in production that totally or partially result from war (whether declared or not), terrorist act, strikes, riots, accidents, fires, floods, natural disasters, transportation delays, shortage of components or materials, governmental decision or action (including prohibition on import/export or the withdrawal of an import/export licence) shall, in particular, be deemed a force majeure.

If one of the parties is delayed or prevented from performing its obligations by reason of this Article for a period in excess of 180 consecutive days, each party may then terminate, by right and without any need for judicial formalities, the unperformed part of the order, by written notice to the other party, without liability. However, the Client shall be required to pay the price agreed pertaining to the Products already delivered on the date of termination.

**XVIII - PROHIBITION ON UNLAWFUL PAYMENTS**

The Client shall refrain from being engaged in any activity that would expose the Seller or any of its affiliates to a risk of penalties under laws and regulations of any relevant jurisdiction prohibiting improper payments, including but not limited to bribes or gifts of an obviously unreasonable amount, to any government or agency officials, to political parties or their officials or candidates for public office, or to any employee of any customer or supplier.

**XIX - TRADE COMPLIANCE LAWS**

The Client agrees that all applicable import, export control and sanctions laws, regulations, orders and requirements, as they may be amended from time to time, including without limitation those of the European Union, the United States of America, and the jurisdictions in which the Seller and the Client are established or from which Products may be supplied, and the requirements of any licences, authorisations, general licences or licence exceptions relating thereto ("Trade Compliance Laws") will apply to its receipt and use of Products, as well as related services and technology. In no event shall the Client use, transfer, release, export or re-export the Products, related services or technology in violation of Trade Compliance Laws.

Seller shall have no obligation to supply any Products, or services unless and until it has received any necessary licences or authorisations or has qualified for general licences or licence exceptions under Trade Compliance Laws.

If for any reason any such licences, authorisations or approvals are denied or revoked, or if there is a change in any Trade Compliance Laws that would prohibit Seller from fulfilling the contract, or would in the reasonable judgement of Seller otherwise expose Seller and/or Seller's Affiliate(s) to a risk of liability under Trade Compliance Laws, Seller shall be relieved without liability of all obligations under the contract.

**XX - SEVERABILITY**

All clauses and/or provisions of these General Conditions that are deemed or become null or void shall not cause the nullity or voidance of the contract, but solely the clause and/or provision concerned.

**XXI - DISPUTES**

**THIS CONTRACT SHALL BE GOVERNED BY AND INTERPRETED IN ACCORDANCE WITH THE LAWS OF FRANCE. ANY DISPUTE IN RELATION TO THE INTERPRETATION OR THE EXECUTION OF THIS CONTRACT NOT AMICABLY SETTLED BETWEEN THE PARTIES WITHIN A 30 DAY PERIOD, SHALL BE SETTLED BY THE COMPETENT COURT OF ANGOULÊME (FRANCE), EVEN IN THE CASE OF INTRODUCTION OF THIRD PARTIES OR THE INVOLVEMENT OF SEVERAL DEFENDANTS. HOWEVER, THE SUPPLIER RESERVES THE EXCLUSIVE RIGHT TO BRING THE DISPUTE TO THE COMPETENT COURTS OF THE SELLER OR THE CLIENT.**



# **WORLD LEADER IN INDUSTRIAL DRIVE SYSTEMS AND ALTERNATORS**

**ELECTRIC MOTORS - GEARBOXES - ELECTRONICS  
ALTERNATORS - ASYNCHRONOUS GENERATORS - DC MACHINES**



**39 PRODUCTION UNITS  
470 SALES & SERVICE CENTRES WORLDWIDE**

MOTEURS LEROY-SOMER - Boulevard Marcellin Leroy - 16015 ANGOULEME Cedex - FRANCE  
Tél. (33) 05 45 64 45 64 - Fax (33) 05 45 64 45 04

[www.leroy-somer.com](http://www.leroy-somer.com)

# International network

[www.leroy-somer.com](http://www.leroy-somer.com)

**ALGERIA**  
LEROY-SOMER International Division

**AUSTRALIA**  
LEROY-SOMER PTY LTD

**AUSTRIA**  
LEROY-SOMER ELEKTROMOTOREN

**BELGIUM**  
LEROY-SOMER BELGIUM

**BRAZIL**  
LEROY-SOMER DIVISION  
EMERSON ELECTRIC DO BRASIL Ltda.

**CANADA**  
LEROY-SOMER / EMC

**CHINA**  
LEROY-SOMER Division

**CROATIA**  
Emerson Network Power Ltd

**CZECH REPUBLIC**  
M.L.S. HOLICE S.R.O.

**DENMARK**  
LEROY-SOMER DENMARK A/S

**EGYPT**  
MOTEURS LEROY-SOMER

**FRANCE**  
MOTEURS LEROY-SOMER

**GERMANY**  
LEROY-SOMER Marbaise GmbH

**GREECE**  
LEROY-SOMER Ltd

**HUNGARY**  
LEROY-SOMER I.M.I.

**INDIA**  
LEROY-SOMER C/O EMERSON ELECTRIC CO.

**ITALIA**  
LEROY-SOMER SPA

**JAPAN**  
LEROY-SOMER DIVISION  
EMERSON Japan Ltd.

**KOREA**  
EMERSON ELECTRIC KOREA

**MOROCCO**  
CARREFOUR INDUSTRIEL ET TECHNOLOGIQUE

**NETHERLANDS**  
LEROY-SOMER NEDERLAND B.V

**POLAND**  
FZN MARBAISE LS

**ROMANIA**  
LEROY-SOMER REPRESENTATIVE OFFICE

**RUSSIA**  
LEROY-SOMER DIVISION

**SAUDI ARABIA**  
ABUNAYYAN TRADING CORPORATION

**SINGAPORE**  
LEROY-SOMER SOUTHEAST ASIA Pte Ltd

**SOUTH AFRICA**  
LEROY-SOMER PTY LTD

**SPAIN**  
LEROY-SOMER IBERICA S.A.

**SWEDEN**  
LEROY-SOMER NORDEN AB

**SWITZERLAND**  
LEROY-SOMER SA

**TAIWAN**  
LEROY-SOMER LIAISON OFFICE

**THAILAND**  
LEROY-SOMER THAILAND

**TUNISIA**  
ULYSSE SPARE PARTS

**TURKEY**  
ELEKTROMEKANIK SISTEMLER

**U.A.E.**  
LEROY-SOMER DIVISION  
EMERSON FZE

**UNITED KINGDOM**  
LEROY-SOMER LTD

**USA**  
LEROY-SOMER POWER AND DRIVES

**VENEZUELA**  
LEROY SOMER C/O EMERSON ELECTRIC CA



**LEROY  
SOMER**

**EMERSON**  
Industrial Automation