



EMERSON™

Industrial Automation

		Mb 2401											
		LS M 3001-3011-3031 (B14-V10-V11) (B11)											
		Triphase LS LSES 4p											
		LS 80V LSES80 LSES100 LSES125 LSES150 LSES175 LSES200											
		Triphase LS 8p			LSES80			LSES100			LSES125		
		80			90			100			110		
6.85	100	2.96	2.04	1.32	0.86								
8.6	80	3.57	2.45	1.59	1.03								
11.4	60	4.29	2.95	1.91	1.24	0.90							
min-1 i exacte													
14.4	100			1.38	1.01	0.84							
17.9	80			1.70	1.24	1.03	0.83						
23.8	60			1.97	1.44	1.20	0.98						
28.6	50			2.35	1.71	1.43	1.14	0.83					
36.0	40			2.88	2.13	1.75	1.41	1.02	0.81				
47.9	30			3.44	2.52	2.10	1.69	1.22	1.02	0.82			
56.3	25.5			3.95	2.88	2.22	1.73	1.29	1.08	0.87			
73.6	19.5			3.59	2.89	2.40	1.74	1.45	1.17	0.85			
99.1	14.5			4.43	3.67	2.94	2.13	1.76	1.44	1.05	0.79		
132	10.3			6.12	5.10	4.09	2.96	2.47	2.00	1.45	1.09		
196	7.25			7.95	6.63	5.31	3.85	3.15	2.50	1.80	1.35		

LS LSES 4p et 8p
LS FCR
LSES FCR
LS 8p et 6p
LS FCR

En fonction des bases de montage F 80

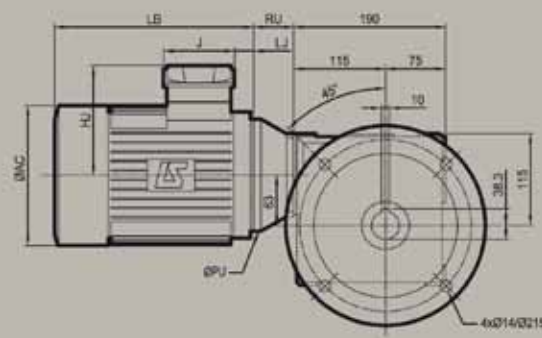
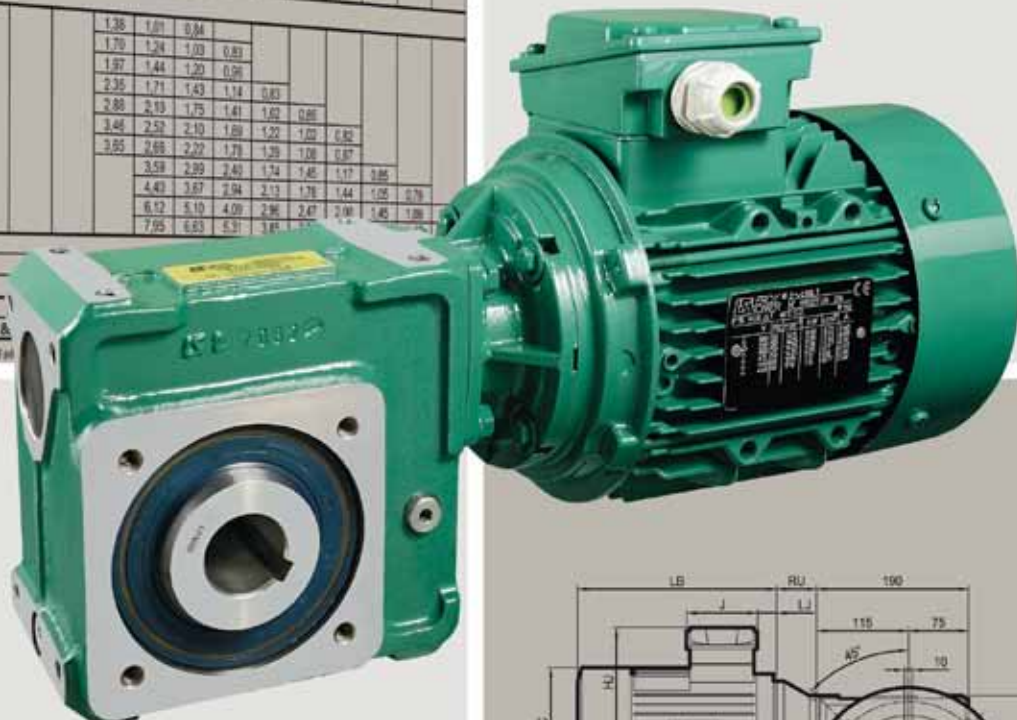

4808 en - 2011.05 / a



Drive systems

MULTIBLOC / LS, LSES

Selection guide

Electromechanical products Multibloc

Contents

General, Construction	3
Mounting - Operating positions	4 to 7
Selection.....	8 to 18
Method	8
Adaptation possibilities, Designation / Coding.....	9
Conditions	10
Mb 3101, AGMA Class I, II, III	11
Mb 2201, AGMA Class I, II, III	12
Mb 2301, AGMA Class I, II, III	13
Mb 2401, AGMA Class I, II, III	14
Mb 2501, AGMA Class I, II, III	15
Mb 2601, AGMA Class I, II, III	16
Mb dimensions	17 to 41
Synthesis	17
Mb dimensions, hollow shaft	18 to 29
Mb 3101, universal mounting MUT	18-19
Mb 2201, universal mounting MUF	20
Mb 2201, universal mounting MUT	21
Mb 2301, universal mounting MUF	22
Mb 2301, universal mounting MUT	23
Mb 2401, universal mounting MUF	24
Mb 2401, universal mounting MUT	25
Mb 2501, universal mounting MUF	26
Mb 2501, universal mounting MUT	27
Mb 2601, universal mounting MUF	28
Mb 2601, universal mounting MUT	29
Mb dimensions, output shaft.....	30 to 41
Mb 3101, universal mounting MUT	30-31
Mb 2201, universal mounting MUF	32
Mb 2201, universal mounting MUT	33
Mb 2301, universal mounting MUF	34
Mb 2301, universal mounting MUT	35
Mb 2401, universal mounting MUF	36
Mb 2401, universal mounting MUT	37
Mb 2501, universal mounting MUF	38
Mb 2501, universal mounting MUT	39
Mb 2601, universal mounting MUF	40
Mb 2601, universal mounting MUT	41
Dimensions of torque arm	42

Electromechanical products

Multibloc

General information



Multibloc geared motors with worm and wheel gears are used to adapt the speed of the electric motor to that of the driven machine.

Their size is therefore determined by the motor power (P) expressed in kilowatts (kW) and the output rotation speed of the gear box (n_S) in revolutions per minute (min⁻¹).

The main characteristic of the speed reducers is the rated output torque (M_{nS}) expressed in Newton-metres (N.m) :

$$M_{nS} = \frac{P \times 9550}{n_S} \times \text{efficiency}$$

A range of six sizes: 31, 22, 23, 24, 25, 26.
Rated output torque: from 20 N.m to 1500 N.m.

Power rating: from 0.18 to 9 kW.

Reduction ratios: from 5.2 to 100.

Efficiency: 55 % to 88 %.

Silent operation.

Construction

Description of Multibloc (Mb) gearboxes

Component	Materials	Remarks
Housing	Cast iron	- use of FGL cast iron (flake graphite: 150 MPa on breaking -Mb 31, 22, 23- and tensile strength 200 MPa -Mb 24, 25, 26-) single component perlite to ensure the complete sealing of the unit - monobloc with reinforced internal ribbing to absorb vibrations and noise and to increase rigidity - with NU housing, it becomes general by the adaptation of: <ul style="list-style-type: none"> • R torque arm kit, • S baseplate (Mb 31 excepted), • BS, BD or BN flanges. They are compact and meet industrial application related requirements.
Wheel	Bronze	- moulded around steel or cast iron inserts, blocked with respect to the worm, supported by two large diameter bearings without intermediate shields (excepting Mb 26)
Worm	Steel	- cut on whirl lathe, tempered and ground
Shafts	Steel	- grinding of the sealing surfaces - hollow cylindrical or output with key in accordance with ISO R773 - diameter tolerance h6 for output shaft and H7 for hollow shaft - tapped holes at output shaft end in accordance with DIN 332 form DR for mounting connecting equipment
Seals	Nitrile	- anti-dust lipseals according to DIN 3760 form AS - ground sealing surfaces
End shields	Cast iron	- on size 26, reinforced by large ribs, ensuring ruggedness of the gearbox under heavy loads
Lubrication	Oil	- in accordance with ISO 6743 / 6 - delivered with the quantity of oil corresponding to a multi-position operation, it is fitted with drain, level and vent plugs (excepting Mb 31)
Mounting		AP : input shaft gearbox (excepting Mb 31) MU (FT or FF) : geared motor with IEC motor, with universal mounting
Standard motor		LS, LSES: multi-voltage 230/400 VY - 400 VΔ - composite material (80 to 100) pressed steel (≥ 112) ventilation cover, on request fitted with a drip cover for operation in vertical position (shaft facing down) - LS: metal terminal box fitted with cable gland - LSES: terminal box made of composite material (80 to 112) aluminium alloy (≥ 132) equipped with threaded plugs (without cable glands) - IP 55 standard protection
Brake motors		FCR: failsafe brake asynchronous motor, ranging from 0.18 to 9 kW, IP 55 protection
Finish	Paint	Shade: RAL 6000 (green), system I (1 couche polyurethane vinyl layer of 25/30 μm)

Electromechanical products Multibloc

Mounting - Operating positions

Standard position: gearbox seen from side F, motor to the rear, side D facing the ground.

1 - Mounting

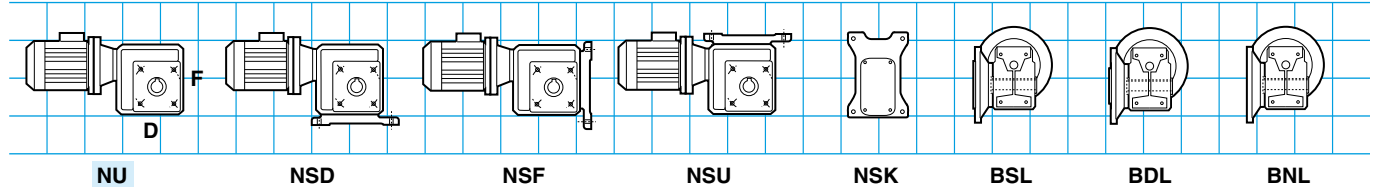

2 - Output shaft

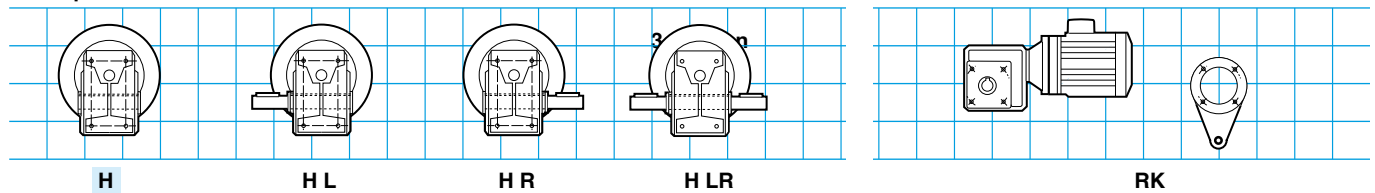

4 - Position

NU, NS, R mounting

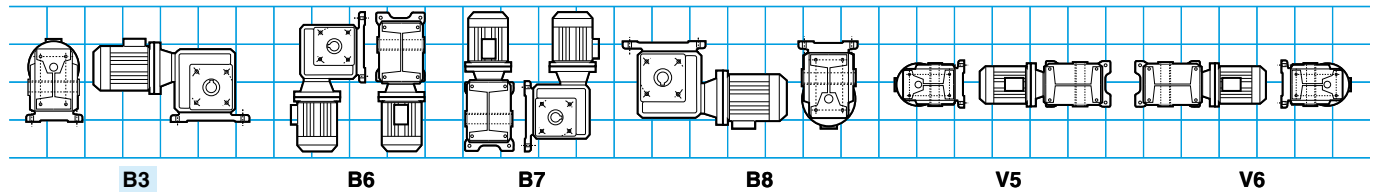

BS, BN, BD mounting

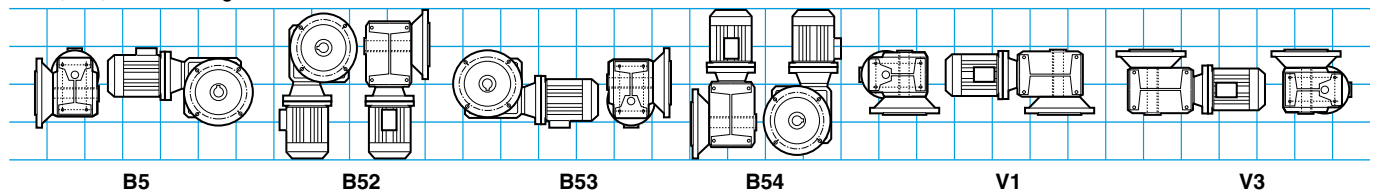

Electromechanical products Multibloc

Mb NU, NS, R operating positions

The absolute orientation of the connection (TB : Up, Down, Right, Left, Front, Back) is related to the chosen operating position.

The relative orientation (0-90-180-270, in the trigonometric direction), a consequence of the absolute position, is related to the base of the gearbox (real or imaginary) for an observer, facing the gearbox.

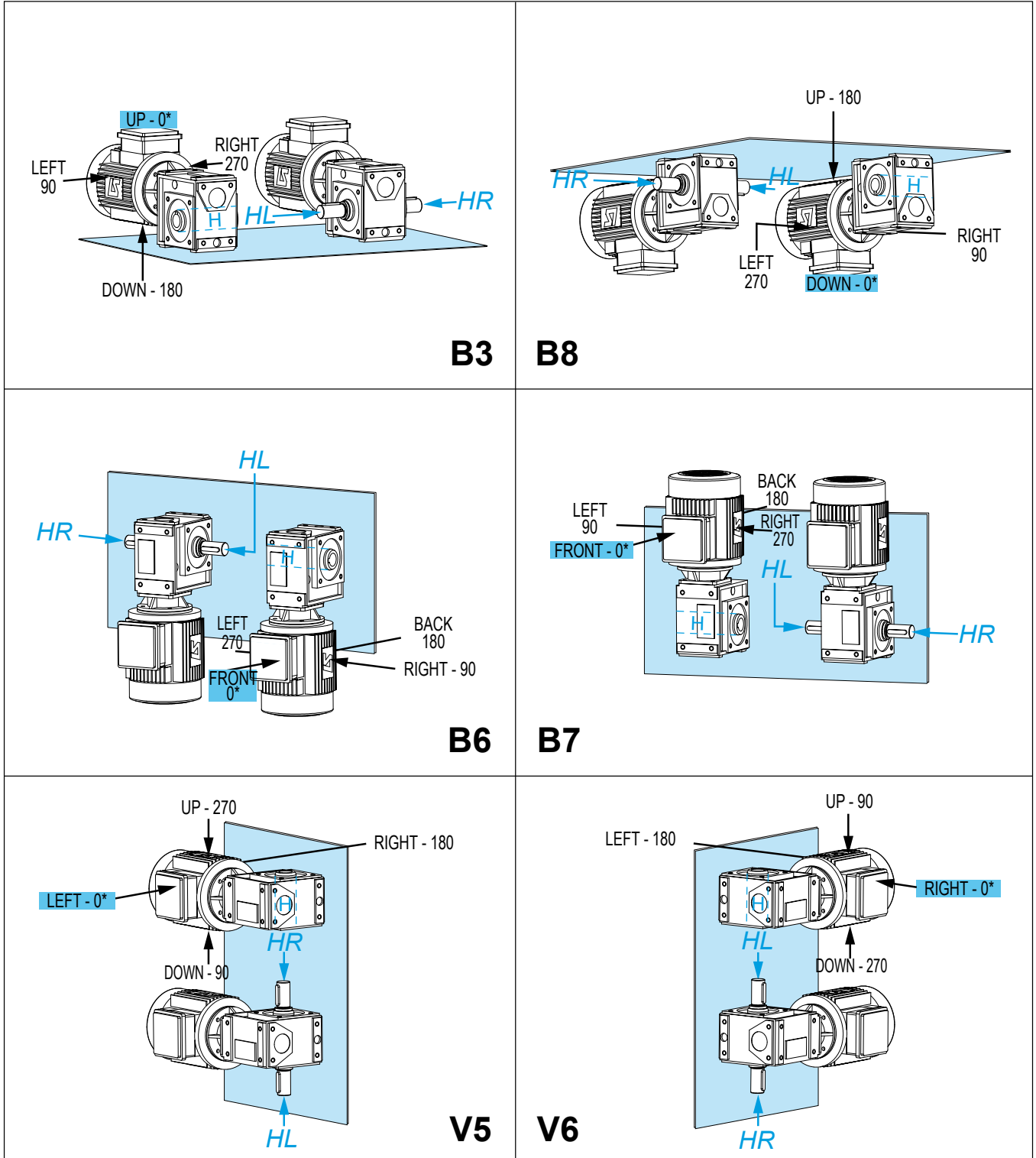

* Std terminal box

Output shaft on left HL, right HR, hollow H.

Electromechanical products Multibloc

Mb BSL, BDL, BNL operating positions

The absolute orientation of the connection (TB : Up, Down, Right, Left, Front, Back) is related to the chosen operating position.

The relative orientation (0-90-180-270, in the trigonometric direction), a consequence of the absolute position, is related to the base of the gearbox (real or imaginary) for an observer, facing the gearbox.

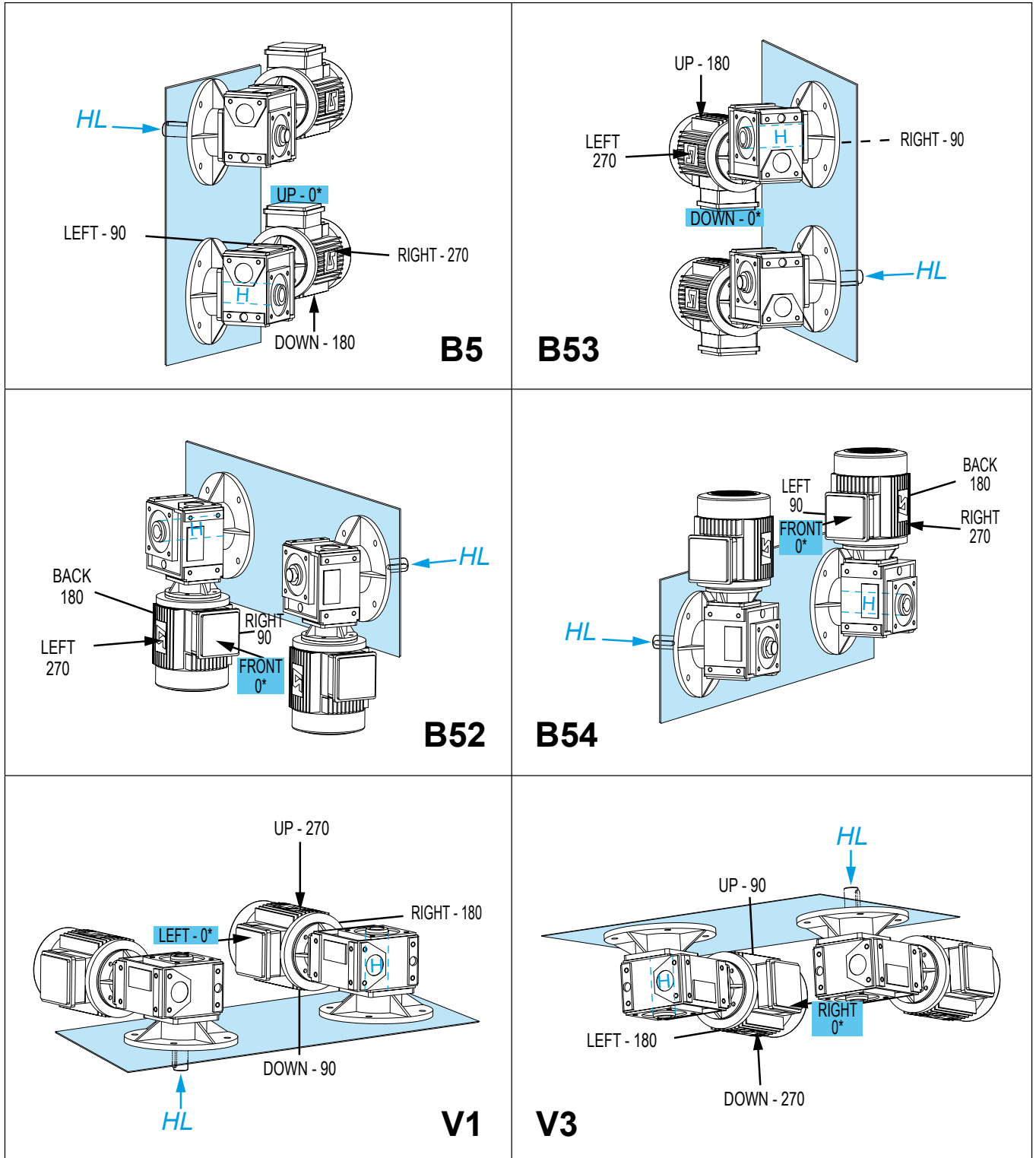

* Std terminal box

Output shaft on left **HL**, right **HR**, hollow **H**.

Electromechanical products Multibloc

Mb BSR, BDR, BNR operating positions

The absolute orientation of the connection (TB : Up, Down, Right, Left, Front, Back) is related to the chosen operating position.

The relative orientation (0-90-180-270, in the trigonometric direction), a consequence of the absolute position, is related to the base of the gearbox (real or imaginary) for an observer, facing the gearbox.

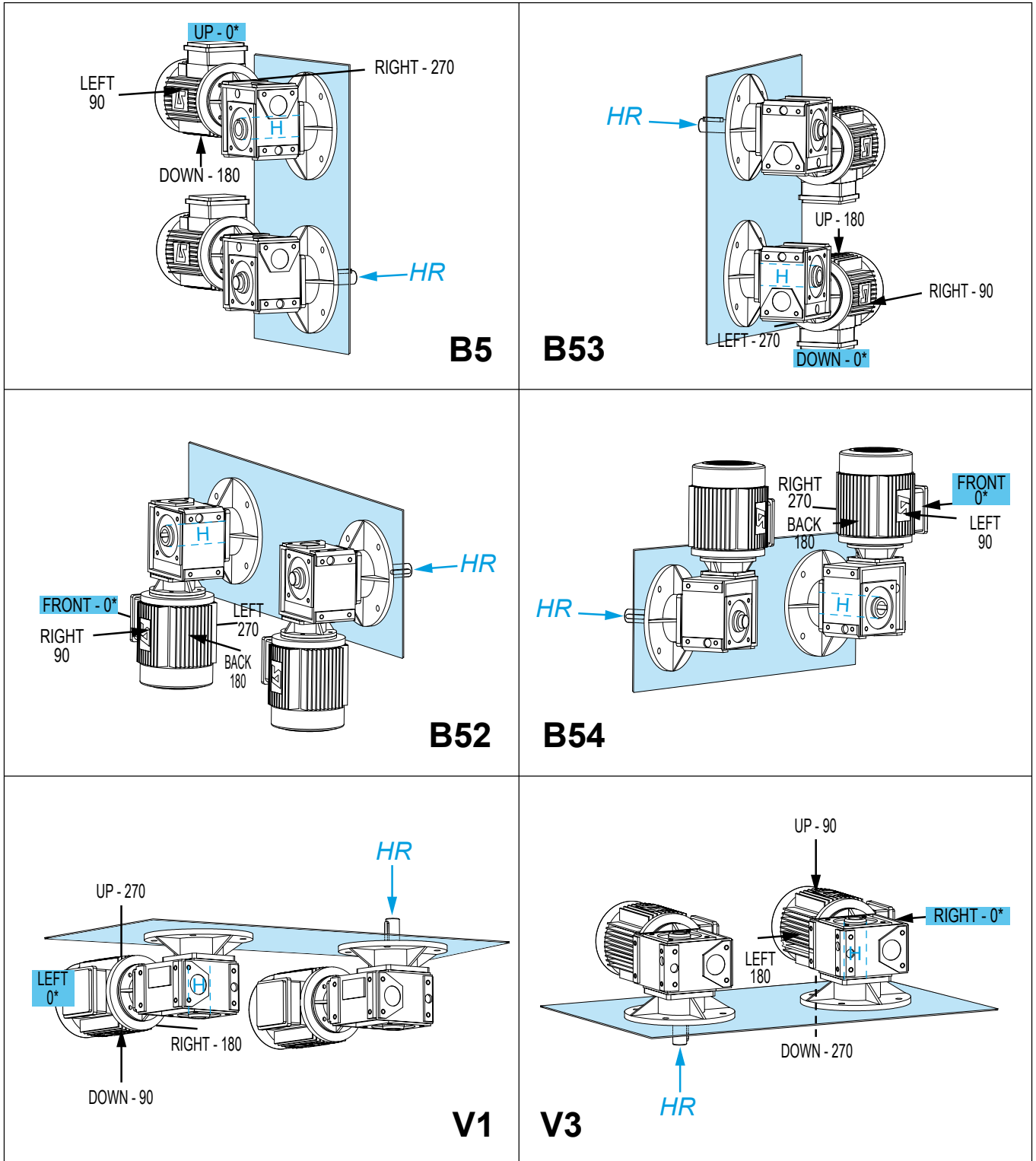

* Std terminal box

Output shaft on left HL, right HR, hollow H.

Electromechanical products Multibloc

Selection

The selection of a gearbox or of a geared motor should take account of the application. Some of these applications are listed in the indicative "AGMA" load classification.

The opposite table summarises the relationship between the "AGMA" class and the gearbox duty factor K_p .

"AGMA" class	Gearbox duty factor K_p
I	1
II	1.4
III	2

NB: In the case of worm and wheel gearboxes such as Multibloc, the operating factor must be taken into account, that is the operating time at full load in relation to the total daily operating time of the gearbox.

In this catalogue, selection is made for an operating factor of 50 %.

For an operating factor of 100 %, class I becomes class II, and class II becomes class III. (K_p multiplied by 1.4)

1st case – Your application is listed

Follow the indicative "AGMA" load classification table, page D0.10 of this catalogue. ▼

Indicative "AGMA" load classification

Applications

OPERATION in hours / day	OPERATION in hours / day		
	3h/day	10h/day	24h/day
CONVEYORS (loaded or fed uniformly)			
belt	I	I	II
chain	I	I	II

Application example: Belt CONVEYOR

Operating time: 10 hours/day

"AGMA" class: I

Gearbox duty factor $K_p = 1$

2nd case – Your application is not listed

The "AGMA" selection class is defined by the daily operating time and by the application operating type, according to the table below ▼

Type of application	Daily operating time	"AGMA" class
Shock-free, few starts	10 hours/day	I
Damped shocks	10 hours/day	II
Shock-free, few starts	24 hours/day	II
Violent shocks, many starts	10 hours/day	III
Damped shocks	24 hours/day	III

Electromechanical products Multibloc

Adaptation possibilities

Leroy-Somer offers several drives for its gearboxes which meet a diverse range of needs. They are described below and offered in this catalogue in the section relating to gearboxes. For other drives, consult Leroy-Somer technical specialists who will be pleased to assist you.

Multibloc Mb gearboxes can be used in conjunction with the following drives:

• 3-phase asynchronous motors:

- LS motor from 0,18 to 9 kW
- LSES motor from 0,75 to 9 kW
- LS motor FCR brake from 0,18 to 9 kW
- LSES motor FCR brake from 0,75 to 9 kW

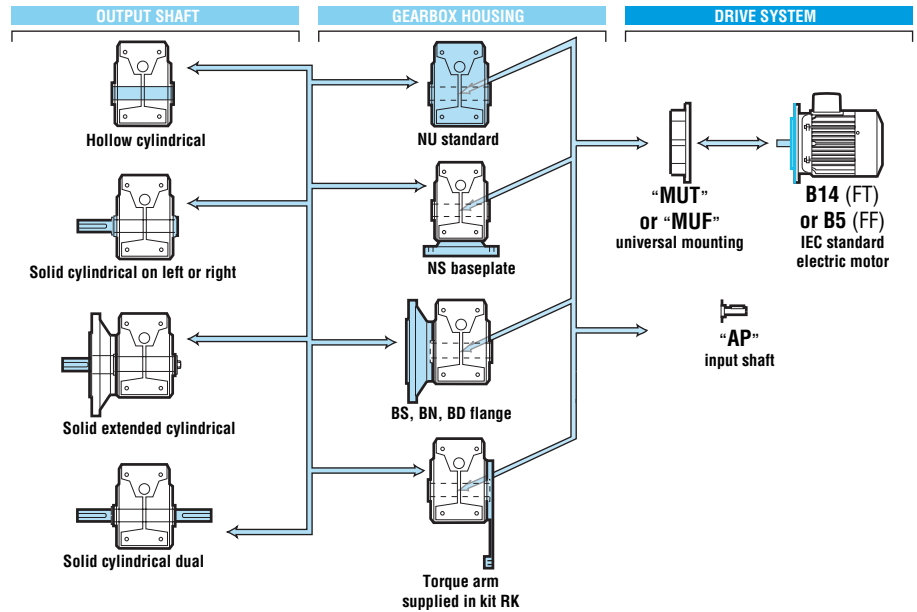

Designation / Coding

Mb	2301	20	NS	D	H	B3	MUT	4P	LSES 90 S	1.1 kW LS2/IE2	230/400 V 50 Hz	UG
Gearbox type	Size	Exact reduction	Mounting type	Mounting position	Output shaft definition	Operating position	Input type	No. of poles	Series, frame size, manufacturer index	Motor power, generation code and η classe	Voltage and mains frequency	Use

Codification example:

Multibloc Mb 2301 - 1.1 kW, 72 min⁻¹, class II

Designation:

Mb 2301 - 20 NS D H B3 MUT

4P LSES 90 S 1,1 kW LS2/IE2 230/400V 50 Hz UG

Code

4749993

Electromechanical products Multibloc

Conditions

Mb : NU, NS, BS, BD, BN, RK

4 pole - LS : IP55 - 50 Hz - Cl. F - 400 VY - from 0,25 to 0,55 kW - **LSES** : IP55 - 50 Hz - Cl. F - 400 VY, 400VΔ from 0,75 to 9 kW LS2/IE2 - U.G.

8 pole - LS : IP55 - 50 Hz - Cl. F - 400 VY - from 0,18 to 3 kW - U.G.

LS FCR brake : IP55 - 50 Hz - Cl. F - 400 V, LS from 0,18 to 9 kW - **LSES FCR brake** : from 0,75 to 9 kW - U.G.

Maximum quantity

Input MUT (b14) MUF (B5)	Mb 3101	Mb 2201	Mb 2301	Mb 2401	Mb 2501	Mb 2601
AP	-	-	-	-	-	-
LS	8p : 0,18 - 2,2 kW	-	5	5	5	5
	4p : 0,25 - 0,55 ¹ kW	5	5	5	5	-
LSES	4p : 0,75 - 9 kW	5	5	5	5	2
	8p : 0,18 - 2,2 kW	-	-	-	-	-
LS FCR	4p : 0,25 - 4 kW	5	5	5	5	2
	4p : 5,5 - 9 kW ²	-	-	-	-	2 ²
LSES FCR	4p : 0,75 - 9 kW	-	-	-	-	-

1. 0,55 kW for LS 71 except Mb 24 with LS 80

2. MUT (B14) only

Mechanical options and pages of dimensions corresponding to mounting and hollow shaft H

Type	Mb forms							
	NU	Baseplate	Flanges mounted			BTLR	Torque arm	Input shaft
		NS D/F/U	BSL / BSR	BDL / BDR	BNL / BNR		RK	AP
Mb 3101	19	-	-	-	18-19	-	42	-
Mb 2201	21	20	21	20	20	-	42	20
Mb 2301	23	22	23	22	22	-	42	22
Mb 2401	25	24	25	24	24	-	42	24
Mb 2501	27	26	27	26	26	-	42	26
Mb 2601	29	28	29	28	28	29	42	28

Mechanical options and pages of dimensions corresponding to mounting and output shaft HL (left) HR (right)

Type	Mb forms					
	NU	Baseplate	Flanges mounted			Input shaft
		NS D/F/U	BSL / BSR	BDL / BDR	BNL / BNR	AP
Mb 3101	31	-	-	-	30-31	-
Mb 2201	33	32	33	32	32	32
Mb 2301	35	34	35	34	34	34
Mb 2401	37	36	37	36	36	36
Mb 2501	39	38	39	38	38	38
Mb 2601	41	40	41	40	40	40

Options

Input 4p / MU	Electrical options			Mechanical options			Brake options		
	230/400V	400V Δ	PTO/CTP	Drip cover	Steel cover	DLRA	Different Mf	TRR	J01
LS	0,18 - 0,55 kW	-	-	-	-	-	-	-	-
	0,75 - 0,9 kW	-	-	-	-	-	-	-	-
LSES	1,1 - 3 kW	-	-	-	-	-	-	-	-
	4 - 9 kW	-	-	-	-	-	-	-	-
LS FCR	0,25 - 3 kW	-	-	-	-	-	-	-	-
	4 - 5,5 kW	-	-	-	-	-	-	-	-
LSES FCR	7,5 - 9 kW ¹	-	-	-	-	-	-	-	-
	0,75 - 9 kW ¹	-	-	-	-	-	-	-	-

1. MUT (B14) only for Mb 26

DG	<	2 WD	<	5 WD	<	10 WD	<	15 WD	<	To be agreed
----	---	------	---	------	---	-------	---	-------	---	--------------

DG : Availability ; n WD : Working Days

Electromechanical products Multibloc

Selection

Classes
I, II, III
(kp = 1, 1.4, 2)

Mb 31
LS IE1, LSES IE2, LSES brake, LS brake - IP 55 - Cl. F
230V/400V Y - 50 Hz - U.G.

Universal mounting **MUT**

		Mb 3101				
		LS IM 3601-3611-3631 (B14-V18-V19) (kW)				
		0,25	0,37	0,55	0,75	0,9
		3-phase LS, LSES 4p				
		LS 71			LSES 80 ¹	
min	i exact					
14,3	100					
17,8	80	0,91				
23,8	60	1,15				
28,5	50	1,40	0,92			
35,6	40	1,94	1,28	0,84		
47,5	30	2,33	1,53	1,00		
57,0	25	2,16	1,42	0,93		
71,3	20	2,85	1,87	1,23	0,91	
95,0	15	3,85	2,53	1,65	1,22	1,01
114	12,5	4,31	2,83	1,85	1,37	1,14
143	10	5,26	3,45	2,26	1,67	1,39
187	7,5	6,52	4,28	2,80	2,07	1,72
LS, LSES 4p and brake		3-phase LS, LSES 4p				
LS FCR		71 L			80 L ¹	
LSES FCR		80 ¹				

1. LSES80 FT 85 ba 14 x 30 obligatory

Selection example

Required power: 0,55 kW

Required speed: 70 min⁻¹

Duty factor necessary for the application: Kp = 1

Operating position ; Mounting form: Horizontal B5; hollow shaft; flange

Designation : Mb 3101 i : 20 BNL H B5 - MUT 4p LS 71 L 0,55 kW - 400V Y - U.G.

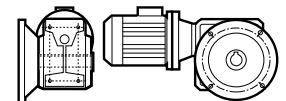

Electromechanical products Multibloc

Selection AGMA I, II, III

Classes
I, II, III
(kp = 1, 1.4, 2)

Mb 2201
LS IE1, LSES IE2, LS brake, LSES brake - IP 55 - Cl. F
230V/400V Y - 50 Hz - U.G.

Universal mounting **MUT**
Input shaft mounting **AP**

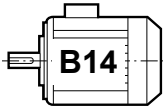

Mb 2201

LS IM 3601-3611-3631 (B14-V18-V19) (kW)

0,18	0,25	0,37	0,55	0,75	0,9	1,1	1,5	1,8
71			80			90		

3-phase LS, LSES 4p

3-phase LS 8p

80

min-1 i exact

7,00	100	1,19	0,83																
8,8	80	1,45	1,02																
11,7	60	1,68	1,18																

min-1 i exact

14,2	100	1,35	0,87																
17,3	80	1,67	1,08																
23,7	60	1,89	1,22	0,79															
28,4	50	2,27	1,47	0,95															
35,5	40	2,69	1,74	1,13	0,83														
47,3	30	3,39	2,19	1,42	1,04	0,87													
55,7	25,5	3,45	2,23	1,44	1,06	0,88													
71,0	20	4,87	3,14	2,04	1,50	1,25	1,01												
94,7	15	6,05	3,91	2,54	1,87	1,56	1,26	0,91											
123	11,5	7,82	5,05	3,27	2,41	2,01	1,62	1,18	0,98										
137	10,3	7,87	5,08	3,30	2,42	2,02	1,63	1,19	0,99										
194	7,33		6,80	4,41	3,25	2,71	2,18	1,59	1,33										

LS, LSES 4p and brake

3-phase LS, LSES 4p

LS FCR 71 L 80 L 90 L

LSES FCR 80 90

LS 8p and brake 3-phase LS 8p

FCR 80

The types of 8-poles motors are in bold italics.

Classes
I, II, III
(kp = 1, 1.4, 2)

Mb 2201
LS IE1, LSES IE2, LS brake, LSES brake - IP 55 - Cl. F
230V/400V Y - 50 Hz - U.G.

Universal mounting **MUF**
Input shaft mounting **AP**

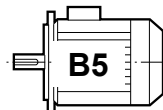

Mb 2201

LS IM 3001-3011-3031 (B5-V1-V3) (kW)

0,18	0,25	0,37	0,55	0,75	0,9	1,1	1,5	1,8
LS 71			LSES 80			LSES 90 ¹		

3-phase LS, LSES 4p

3-phase LS 8p

80

min-1 i exact

7,00	100	1,19	0,83																
8,8	80	1,45	1,02																
11,7	60	1,68	1,18																

min-1 i exact

14,2	100	1,35	0,87																
17,3	80	1,67	1,08																
23,7	60	1,89	1,22	0,79															
28,4	50	2,27	1,47	0,95															
35,5	40	2,69	1,74	1,13	0,83														
47,3	30	3,39	2,19	1,42	1,04	0,87													
55,7	25,5	3,45	2,23	1,44	1,06	0,88													
71,0	20	4,87	3,14	2,04	1,50	1,25	1,01												
94,7	15	6,05	3,91	2,54	1,87	1,56	1,26	0,91											
123	11,5	7,82	5,05	3,27	2,41	2,01	1,62	1,18	0,98										
137	10,3	7,87	5,08	3,30	2,42	2,02	1,63	1,19	0,99										
194	7,33		6,80	4,41	3,25	2,71	2,18	1,59	1,33										

LS, LSES 4p and brake

3-phase LS, LSES 4p

LS FCR 71 L 80 L 90 L¹

LSES FCR 80 90¹

LS 8p and brake 3-phase LS 8p

LS FCR 80

The types of 8-poles motors are in bold italics.

1. LSES90 FF130 ba 19 x 40 obligatory

Selection example

Required power: 0,55 kW
 Required speed: 35 min-1
 Duty factor necessary for the application: Kp = 1
 Operating position ; Mounting form: Horizontal B3 ; hollow shaft; baseplate
 Designation: Mb 2201 B3 NSD H i: 40 MUF - 4p LS 71 L 0,55 kW - 400V Y - U.G.

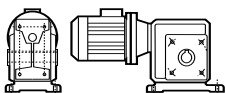

Electromechanical products Multibloc

Selection AGMA I, II, III

Classes
I, II, III
(kp = 1, 1.4, 2)

Mb 2301
LS IE1, LSES IE2, LS brake, LSES brake - IP 55 - Cl. F
230V/400V Y - 400V Δ - 50 Hz - U.G.

Universal mounting **MUT**
Input shaft mounting **AP**

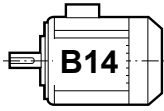

Mb 2301

LS IM 3601-3611-3631 (B14-V18-V19) (kW)

		0,18	0,25	0,37	0,55	0,75	0,9	1,1	1,5	1,8	2,2	3	4			
		3-phase LS, LSES 4p														
		LS 71			LSES 80			LSES 90			LSES 100 ¹		LSES112 ²			
		3-phase LS 8p														
		80			90											
min-1	i exact															
7,00	100	2,01	1,39	0,90												
8,8	80	2,60	1,81	1,18												
11,7	60	2,94	2,04	1,33	0,87											
min-1	i exact															
14,2	100	2,35	1,50	0,96												
17,8	80	2,67	1,70	1,10	0,80											
23,7	60	3,29	2,10	1,35	0,99	0,83										
28,4	50	3,95	2,52	1,62	1,19	0,99	0,80									
35,5	40	4,82	3,08	1,98	1,45	1,21	0,97									
47,3	30	5,71	3,64	2,34	1,72	1,43	1,15	0,84								
55,7	25,5	6,01	3,83	2,46	1,81	1,51	1,21	0,88								
71,0	20	7,90	5,04	3,24	2,38	1,98	1,59	1,16	0,97							
94,7	15	8,77	5,59	3,60	2,64	2,20	1,77	1,29	1,08	0,87						
123	11,5		8,39	5,39	3,96	3,30	2,65	1,93	1,61	1,30	0,95					
137	10,3		8,46	5,44	3,99	3,33	2,67	1,94	1,62	1,31	0,96					
189	7,5				7,47	5,48	4,57	3,67	2,67	2,23	1,80	1,31	0,99			
273	5,2					7,44	6,20	4,99	3,62	3,02	2,45	1,78	1,34			
LS, LSES 4p and brake		3-phase LS, LSES 4p														
LS FCR		71 L			80 L			90 L			100 L ¹		112 ²			
LSES FCR					80			90			100 ¹		112 ²			
LS 8p and brake		3-phase LS 8p														
LS FCR		80			90											

The types of 8-poles motors are in bold italics. 1. LSES100 FT 115 ba 24 x 50 obligatory. 2. LSES112 FT 115 ba 24 x 50 obligatory

Classes
I, II, III
(kp = 1, 1.4, 2)

Mb 2301
LS IE1, LSES IE2, LS brake, LSES brake - IP 55 - Cl. F
230V/400V Y - 400V Δ - 50 Hz - U.G.

Universal mounting **MUF**
Input shaft mounting **AP**

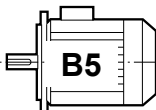

Mb 2301

LS IM 3001-3011-3031 (B5-V1-V3) (kW)

		0,18	0,25	0,37	0,55	0,75	0,9	1,1	1,5	1,8	2,2	3	4			
		3-phase LS, LSES 4p														
		LS 71			LSES 80			LSES 90			LSES 100 ¹		LSES112 ²			
		3-phase LS 8p														
		80			90											
min-1	i exact															
7,00	100	2,01	1,39	0,90												
8,8	80	2,60	1,81	1,18												
11,7	60	2,94	2,04	1,33	0,87											
min-1	i exact															
14,2	100	2,35	1,50	0,96												
17,8	80	2,67	1,70	1,10	0,80											
23,7	60	3,29	2,10	1,35	0,99	0,83										
28,4	50	3,95	2,52	1,62	1,19	0,99	0,80									
35,5	40	4,82	3,08	1,98	1,45	1,21	0,97									
47,3	30	5,71	3,64	2,34	1,72	1,43	1,15	0,84								
55,7	25,5	6,01	3,83	2,46	1,81	1,51	1,21	0,88								
71,0	20	7,90	5,04	3,24	2,38	1,98	1,59	1,16	0,97							
94,7	15	8,77	5,59	3,60	2,64	2,20	1,77	1,29	1,08	0,87						
123	11,5		8,39	5,39	3,96	3,30	2,65	1,93	1,61	1,30	0,95					
137	10,3		8,46	5,44	3,99	3,33	2,67	1,94	1,62	1,31	0,96					
189	7,5				7,47	5,48	4,57	3,67	2,67	2,23	1,80	1,31	0,99			
273	5,2					7,44	6,20	4,99	3,62	3,02	2,45	1,78	1,34			
LS, LSES 4p and brake		3-phase LS, LSES 4p														
LS FCR		71 L			80 L			90 L			100 L ¹		112 ²			
LSES FCR					80			90			100 ¹		112 ²			
LS 8p and brake		3-phase LS 8p														
LS FCR		80			90											

The types of 8-poles motors are in bold italics. 1. LSES100 FF 165 ba 24 x 50 obligatory. 2. LSES112 FF 165 ba 24 x 50 obligatory

Selection example

Required power: 1,1 kW
 Required speed: 70 min-1
 Duty factor necessary for the application: Kp = 1,4
 Operating position ; Mounting form: Horizontal B8 ; hollow shaft; flange
 Designation : Mb 2301 i : 20 NSD H B8 - MUT 4p LSES90S 1,1 kW LS2/IE2 - 400V Y - U.G.

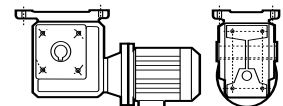

Electromechanical products Multibloc

Selection AGMA I, II, III

Classes
I, II, III
(kp = 1, 1.4, 2)

Mb 2401
LS IE1, LSES IE2, LS brake, LSES brake - IP 55 - Cl. F
230V/400V Y - 400V Δ - 50 Hz - U.G.

Universal mounting **MUT**
Input shaft mounting **AP**

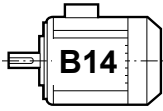

Mb 2401

LS IM 3601-3611-3631 (B14-V18-V19) (kW)

0,18	0,25	0,37	0,55	0,75	0,9	1,1	1,5	1,8	2,2	3	4	5,5
LS 80 ¹			LSES80			LSES90			LSES100	LSES112	LSES132 ²	

3-phase LS 8p

min-1	i exact	80	90	100								
6,85	100	2,96	2,04	1,32	0,86							
8,6	80	3,57	2,46	1,59	1,03							
11,4	60	4,29	2,96	1,91	1,24	0,90						

min-1	i exact													
14,4	100				1,38	1,01	0,84							
17,9	80				1,70	1,24	1,03	0,83						
23,8	60				1,97	1,44	1,20	0,96						
28,6	50				2,35	1,71	1,43	1,14	0,83					
36,0	40				2,88	2,10	1,75	1,41	1,02	0,85				
47,9	30				3,46	2,52	2,10	1,69	1,22	1,02	0,82			
56,3	25,5				3,65	2,66	2,22	1,78	1,29	1,08	0,87			
73,6	19,5					3,59	2,99	2,40	1,74	1,45	1,17	0,85		
99,1	14,5					4,40	3,67	2,94	2,13	1,78	1,44	1,05	0,79	
139	10,3					6,12	5,10	4,09	2,96	2,47	2,00	1,45	1,09	0,79
198	7,25					7,95	6,63	5,31	3,85	3,21	2,59	1,89	1,42	1,03

LS, LSES 4p and brake		3-phase LS, LSES 4p										
LS FCR		80 L			90 L			100 L			112	132 ²
LSES FCR		80			90			100			112	132 ²
LS 8p and brake		3-phase LS 8p										
LS FCR		80	90	100								

The types of 8-poles motors are in bold italics. 1. 0,55 kW for LS 80 (FT 100 ba 19 x 40). 2. LSES132 FT130 ba 28 x 60 obligatory.

Classes
I, II, III
(kp = 1, 1.4, 2)

Mb 2401
LS IE1, LSES IE2, LS brake, LSES brake - IP 55 - Cl. F
230V/400V Y - 400V Δ - 50 Hz - U.G.

Universal mounting **MUT**
Input shaft mounting **AP**

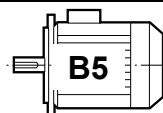

Mb 2401

LS IM 3001-3011-3031 (B5-V1-V3) (kW)

0,18	0,25	0,37	0,55	0,75	0,9	1,1	1,5	1,8	2,2	3	4	5,5
LS 71			LSES80			LSES90			LSES100	LSES112	LSES132 ¹	

3-phase LS 8p

min-1	i exact	80	90	100								
7,00	100	2,96	2,04	1,32	0,86							
8,8	80	3,57	2,46	1,59	1,03							
11,7	60	4,29	2,96	1,91	1,24	0,90						

min-1	i exact															
14,4	100				3,43	2,16	1,38	1,01	0,84							
17,9	80				4,24	2,67	1,70	1,24	1,03	0,83						
23,8	60				4,91	3,09	1,97	1,44	1,20	0,96						
28,6	50				5,84	3,67	2,35	1,71	1,43	1,14	0,83					
36,0	40				7,17	4,52	2,88	2,10	1,75	1,41	1,02	0,85				
47,9	30				8,60	5,42	3,46	2,52	2,10	1,69	1,22	1,02	0,82			
56,3	25,5				9,08	5,37	3,65	2,66	2,22	1,78	1,29	1,08	0,87			
73,6	19,5							3,59	2,99	2,40	1,74	1,45	1,17	0,85		
99,1	14,5							4,40	3,67	2,94	2,13	1,78	1,44	1,05	0,79	
139	10,3							6,12	5,10	4,09	2,96	2,47	2,00	1,45	1,09	0,79
198	7,25							7,95	6,63	5,31	3,85	3,21	2,59	1,89	1,42	1,03

LS, LSES 4p and brake		3-phase LS, LSES 4p												
LS FCR		71 L			80 L			90 L			100 L		112	132 ¹
LSES FCR		80			90			100			112	132 ¹		
LS 8p and brake		3-phase LS 8p												
LS FCR		80	90	100										

The types of 8-poles motors are in bold italics. 1. LSES132 FF 165 ba 28 x 60 obligatory.

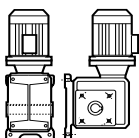

Selection example

Required power: 1,1 kW
 Required speed: 73 min-1
 Duty factor necessary for the application: Kp = 2
 Operating position ; Mounting form: B7 ; hollow shaft; baseplate
Designation : Mb 2401 i : 19,5 NSD H B7 - MUT 4p LSES90S 1,1 kW LS2/IE2 - 400V Y - U.G.

Electromechanical products Multibloc

Selection AGMA I, II, III

Classes
I, II, III
(kp = 1, 1.4, 2)

Mb 2501
LS IE1, LSES IE2, LS brake, LSES brake - IP 55 - Cl. F
230V/400V Y - 400V Δ - 50 Hz - U.G.

Universal mounting **MUT**
Input shaft mounting **AP**

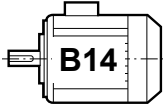

Mb 2501

LS IM 3601-3611-3631 (B14-V18-V19) (kW)

		0,37	0,55	0,75	0,9	1,1	1,5	1,8	2,2	3	4	5,5	7,5	9
		3-phase LS, LSES 4p												
		LS 71	LSES80		LSES90			LSES100		LSES112	LSES132 ¹			
		3-phase LS 8p												
min-1	i exact	90	100		100	112								
7,00	100	2,34	1,51	1,09										
8,8	80	3,05	1,97	1,42		0,96								
11,7	60	3,60	2,32	1,68		1,13	0,85							
min-1	i exact													
14,4	100		1,80	1,50	1,19	0,86								
18,0	80		2,38	1,98	1,58	1,14	0,95							
24,0	60		2,73	2,28	1,81	1,31	1,09	0,88						
28,8	50		3,24	2,70	2,15	1,55	1,29	1,04						
36,0	40		3,99	3,33	2,64	1,91	1,59	1,28	0,93					
47,9	30		4,98	4,15	3,30	2,39	1,99	1,60	1,17	0,88				
56,4	25,5		5,59	4,66	3,71	2,68	2,23	1,80	1,31	0,98				
70,2	20,5		6,60	5,50	4,38	3,16	2,63	2,12	1,54	1,16	0,84			
92,8	15,5				5,48	3,96	3,30	2,66	1,93	1,45	1,05			
139	10,3				8,21	5,93	4,94	3,98	2,90	2,17	1,57	1,15	0,96	
198	7,25					7,80	6,50	5,24	3,81	2,86	2,07	1,52	1,26	
		3-phase LS, LSES 4p												
LS FCR			80		90		100		112		132 ¹			
LSES FCR			80		90		100		112		132 ¹			
		3-phase LS 8p												
LS FCR		90	100		100	112								

The types of 8-poles motors are in bold italics. 1. LSES132 FT 130 ba 28 x 60 obligatory

Classes
I, II, III
(kp = 1, 1.4, 2)

Mb 2501
LS IE1, LSES IE2, LS brake, LSES brake - IP 55 - Cl. F
230V/400V Y - 400V Δ - 50 Hz - U.G.

Universal mounting **MUF**
Input shaft mounting **AP**

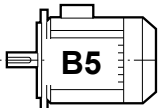

Mb 2501

LS IM 3001-3011-3031 (B5-V1-V3) (kW)

		0,37	0,55	0,75	0,9	1,1	1,5	1,8	2,2	3	4	5,5	7,5	9
		3-phase LS, LSES 4p												
		LS 71	LSES80		LSES90			LSES100		LSES112	LSES132 ¹			
		3-phase LS 8p												
min-1	i exact	90	100		100	112								
7,00	100	2,34	1,51	1,09										
8,8	80	3,05	1,97	1,42		0,96								
11,7	60	3,60	2,32	1,68		1,13	0,85							
min-1	i exact													
14,4	100		1,80	1,50	1,19	0,86								
18,0	80		2,38	1,98	1,58	1,14	0,95							
24,0	60		2,73	2,28	1,81	1,31	1,09	0,88						
28,8	50		3,24	2,70	2,15	1,55	1,29	1,04						
36,0	40		3,99	3,33	2,64	1,91	1,59	1,28	0,93					
47,9	30		4,98	4,15	3,30	2,39	1,99	1,60	1,17	0,88				
56,4	25,5		5,59	4,66	3,71	2,68	2,23	1,80	1,31	0,98				
70,2	20,5		6,60	5,50	4,38	3,16	2,63	2,12	1,54	1,16	0,84			
92,8	15,5				5,48	3,96	3,30	2,66	1,93	1,45	1,05			
139	10,3				8,21	5,93	4,94	3,98	2,90	2,17	1,57	1,15	0,96	
198	7,25					7,80	6,50	5,24	3,81	2,86	2,07	1,52	1,26	
		3-phase LS, LSES 4p												
LS FCR			80		90		100		112		132 ¹			
LSES FCR			80		90		100		112		132 ¹			
		3-phase LS 8p												
LSFCR		90	100		100	112								

The types of 8-poles motors are in bold italics. 1. LSES132 FF 165 ba 28 x 60 obligatory

Selection example

Required power: 3 kW
 Required speed: 47,5 min-1
 Duty factor necessary for the application: Kp = 1
 Operating position ; Mounting form: Horizontal B3 ; shaft on the left
Designation : Mb 2501 B3 NU HL i : 30 MUT - 4p LSES100LR 3 kW LS2/IE2 - 400V Y - U.G.

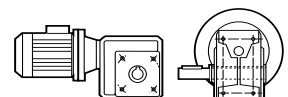

Electromechanical products

Multibloc

Classes
I, II, III
(kp = 1, 1.4, 2)

Mb 2601
LS IE1, LSES IE2, LS brake, LSES brake - IP 55 - Cl. F
230V/400V Y - 400V Δ - 50 Hz - U.G.

Universal mounting **MUT**
Input shaft mounting **AP**

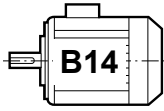

Mb 2601

LS IM 3601-3611-3631 (B14-V18-V19) (kW)

		0,37	0,55	0,75	0,9	1,1	1,5	1,8	2,2	3	4	5,5	7,5	9
		3-phase LS, LSES 4p												
		LS 71	LSES80		LSES90		LSES100 ¹		LSES112 ¹		LSES132			
		3-phase LS 8p												
min-1	i exact		100¹		100¹	112¹			132					
7,00	100		1,96		1,32	1,00								
8,8	80		2,55		1,71	1,29			0,98					
11,7	60		2,91		1,95	1,48			1,00					
min-1	i exact								1,04					
14,4	100								1,34	0,98				
18,0	80								1,58	1,15	0,86			
23,9	60								1,91	1,39	1,04			
28,7	50								2,37	1,72	1,29	0,93		
36,0	40								2,51	1,82	1,37	0,99		
47,9	30								3,16	2,29	1,72	1,24	0,91	
56,4	25,5								3,97	2,88	2,16	1,56	1,14	0,95
70,2	20,5								5,14	3,73	2,8	2,02	1,48	1,23
92,8	15,5								7,21	5,23	3,92	2,83	2,08	1,73
139	10,3								8,75	6,35	4,76	3,44	2,52	2,1
192	7,5													
LS, LSES 4p and brake		3-phase LS, LSES 4p												
LS FCR									100 ¹	112 ¹				132
LSES FCR									100 ¹	112 ¹				132
LS 8p and brake		3-phase LS 8p												
FCR			100¹		100¹	112¹			132					

The types of 8-poles motors are in bold italics. 1. LSES100 and 112 FT215 ba 38 x 80 obligatory

Classes
I, II, III
(kp = 1, 1.4, 2)

Mb 2601
LS IE1, LSES IE2, LS brake, LSES brake - IP 55 - Cl. F
230V/400V Y - 400V Δ - 50 Hz - U.G.

Universal mounting **MUF**
Input shaft mounting **AP**

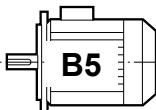

Mb 2601

LS IM 3001-3011-3031 (B5-V1-V3) (kW)

		0,37	0,55	0,75	0,9	1,1	1,5	1,8	2,2	3	4	5,5	7,5	9
		3-phase LS, LSES 4p												
		LS 71	LSES80		LSES90		LSES100		LSES112		LSES132 ¹			
		3-phase LS 8p												
min-1	i exact	90	100		100	112			132¹					
7,00	100	4,26	2,72	1,96		1,32	1,00							
8,8	80	5,54	3,54	2,55		1,71	1,29		0,98					
11,7	60	6,32	4,04	2,91		1,95	1,48		1,00					
min-1	i exact								2,16	1,56	1,30	1,04		
14,4	100								2,79	2,01	1,68	1,34	0,98	
18,0	80								3,29	2,37	1,98	1,58	1,15	0,86
23,9	60								3,97	2,85	2,38	1,91	1,39	1,04
28,7	50								4,93	3,54	2,95	2,37	1,72	1,29
36,0	40								5,21	3,75	3,13	2,51	1,82	1,37
47,9	30								6,56	4,72	3,93	3,16	2,29	1,72
56,4	25,5								8,25	5,93	4,94	3,97	2,88	2,16
70,2	20,5											1,56	1,14	0,95
92,8	15,5									7,69	6,41	5,14	3,73	2,8
139	10,3										8,98	7,21	5,23	3,92
192	7,5										8,75	6,35	4,76	3,44
LS, LSES 4p and brake		3-phase LS, LSES 4p												
LS FCR						90			100	112				132 ¹
LSES FCR						90			100	112				132 ¹
LS 8p and brake		3-phase LS 8p												
FCR		90	100		100	112			132¹					

The types of 8-poles motors are in bold italics. 1. LSES132 FF 165 ba 28 x 60 obligatory

Selection example



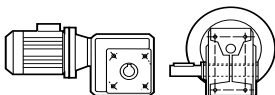





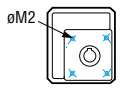

Required power: 7,5 kW
 Required speed: 70 min-1
 Duty factor necessary for the application: Kp = 1
 Operating position ; Mounting form: Horizontal B3 ; shaft on the left
 Designation : Mb 2601 i : 20,5 NU HL B3 - MUF 4p LSES132M 7,5 kW LS2/IE2 - 400V Y - U.G.

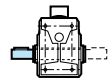
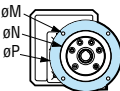
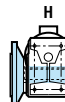
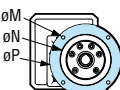

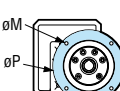
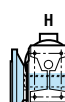
Electromechanical products Multibloc

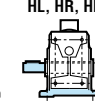
Synthesis

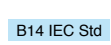
Dimensions in mm

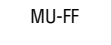
Mountings	Shaft	MULTIBLOC								
		Mb 31	Mb 22	Mb 23	Mb 24	Mb 25	Mb 26			
 øM2	 H	Ø 20H7 x 90 M2 = 85	Ø 25H7 x 108 M2 = 105	Ø 30H7 x 118 M2 = 115	Ø 35H7 x 138 M2 = 130	Ø 45H7 x 168 M2 = 180	Ø 50H7 x 188 -			
	 HL HR HLR	Ø 20h6 x 40 M2 = 85	Ø 25h6 x 50 M2 = 105	Ø 30h6 x 60 M2 = 115	Ø 35h6 x 70 M2 = 130	Ø 45h6 x 90 M2 = 180	Ø 50h6 x 100 -			
 øM øN øP	 H	HL, HR, HLR	H HL HR HLR	- - -	M = 165 N = 130 P = 200	M = 165 N = 130 P = 200	M = 215 N = 180 P = 250	M = 265 N = 230 P = 300	M = 300 N = 250 P = 350	
 øM øN øP	 H	HL, HR, HLR	H HL HR HLR	- - -	M = 130 N = 110 P = 160	M = 130 N = 110 P = 160	M = 165 N = 130 P = 200	M = 215 N = 180 P = 250	M = 265 N = 230 P = 300	
 øM øP	 H	HL, HR, HLR	H HL HR HLR	M = 100/85/115 P = 120/105/140	M = 165 N = 200	M = 165 N = 200	M = 215 N = 250	M = 265 N = 300	M = 300 N = 350	
 A	 H	 HL, HR, HLR	H HL HR HLR	- -	A = 134 B = 125	A = 154 B = 128	A = 202 B = 156	A = 220 B = 156	A = 250 B = 180	
			Frame size							
MU/LS, LSES	 MU-FT	 B14 IEC Std	71	FT85-14x30	FT85-14x30	FT85-14x30	-	-	-	
			80	FT85-14x30	FT85-14x30	FT85-14x30	-	-	-	
 MU-FF	 B5 IEC Std	80	-	FT100-19x40	FT100-19x40	FT100-19x40	FT100-19x40	FT100-19x40	-	
		80	-	-	FT115-24x50	FT115-24x50	FT115-24x50	FT115-24x50	FT115-24x50	-
			90	-	FT100-19x40	FT100-19x40	FT100-19x40	FT100-19x40	FT100-19x40	-
			90	-	-	FT115-24x50	FT115-24x50	FT115-24x50	FT115-24x50	-
			90	-	-	-	FT130-28x60	FT130-28x60	FT130-28x60	-
			100	-	-	FT115-24x50	FT115-24x50	FT115-24x50	FT115-24x50	-
			100	-	-	-	FT130-28x60	FT130-28x60	FT130-28x60	-
			100	-	-	-	-	-	-	FT215-38x80
			112	-	-	FT115-24x50	FT115-24x50	FT115-24x50	FT115-24x50	-
			112	-	-	-	FT130-28x60	FT130-28x60	FT130-28x60	-
			112	-	-	-	-	-	-	FT215-38x80
			132	-	-	-	FT130-28x60	FT130-28x60	FT130-28x60	-
			132	-	-	-	-	-	-	FT215-38x80
			71	-	FF130-14x30	FF130-14x30	FF130-14x30	-	-	-
			80	-	FF130-14x30	FF130-14x30	-	-	-	-
			80	-	FF165-19x40	FF165-19x40	FF165-19x40	FF165-19x40	FF165-19x40	-
			80	-	-	FF165-19x40	-	-	-	-
			90	-	FF165-19x40	FF165-19x40	FF165-19x40	FF165-19x40	FF165-19x40	-
			90	-	FF130-19x40	FF165-24x50	FF165-24x50	FF165-24x50	FF165-24x50	FF165-24x50
			90	-	-	-	FF215-28x60	FF215-28x60	FF215-28x60	FF215-28x60
			100	-	-	FF165-24x50	FF165-24x50	FF165-24x50	FF165-24x50	FF165-24x50
			100	-	-	-	FF215-28x60	FF215-28x60	FF215-28x60	FF215-28x60
			112	-	-	FF165-24x50	FF165-24x50	FF165-24x50	FF165-24x50	FF165-24x50
			112	-	-	-	FF215-28x60	FF215-28x60	FF215-28x60	FF215-28x60
			132	-	-	-	FF165-28X60	FF165-28X60	FF165-28X60	FF165-28X60
			132	-	-	-	FF215-28x60	FF215-28x60	FF215-28x60	FF215-28x60

Electromechanical products

Multibloc

Dimensions

Dimensions of Multibloc (Mb) geared motors, MU universal mounting,
Mb 3101

Dimensions in millimetres

- BN1 L* flange on left, H hollow shaft

Mb : 6 kg
+ mot

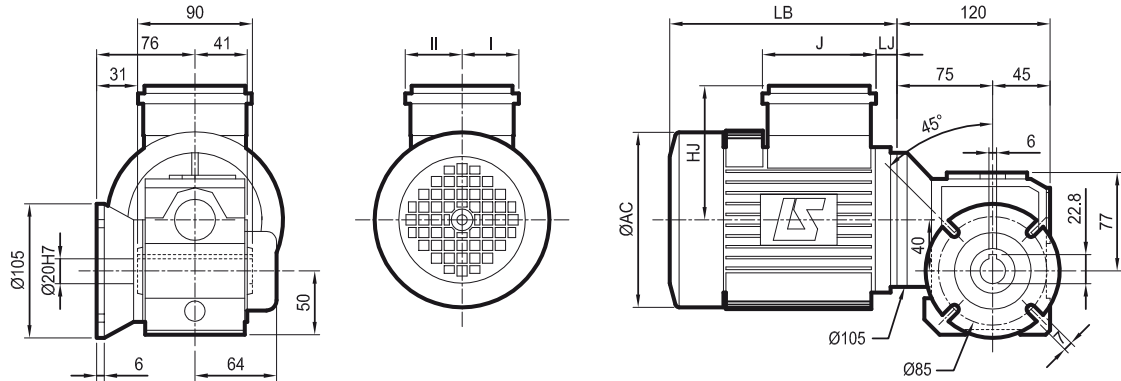

* option on right BN1 R H : identical flange and shaft

- BN2 L* flange on left, H hollow shaft

Mb : 6,2 kg
+ mot

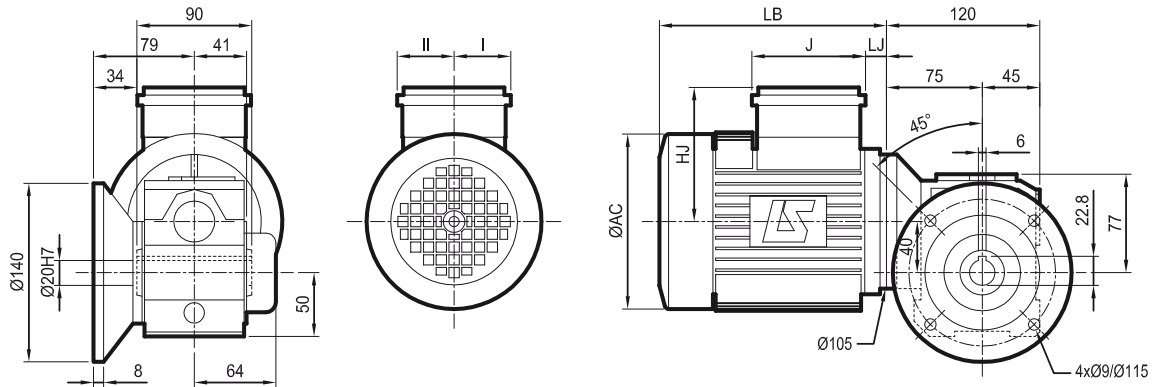

* option on right BN2 R H : identical flange and shaft

- Driven shaft details

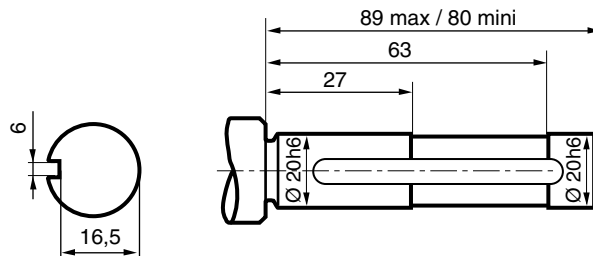

Electromechanical products

Multibloc

Dimensions

Dimensions of Multibloc (Mb) geared motors, MU universal mounting, Mb 3101 MUT LS

Dimensions in millimetres

- NU standard, H hollow shaft

Mb : 5 kg
+ mot

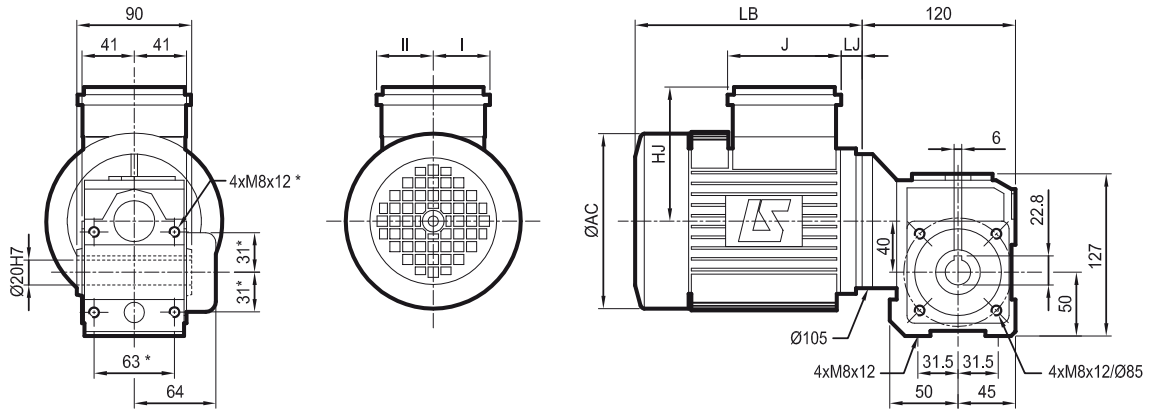

* option NUF on request

- BN L* flange on left, H* hollow shaft

Mb : 6 kg
+ mot

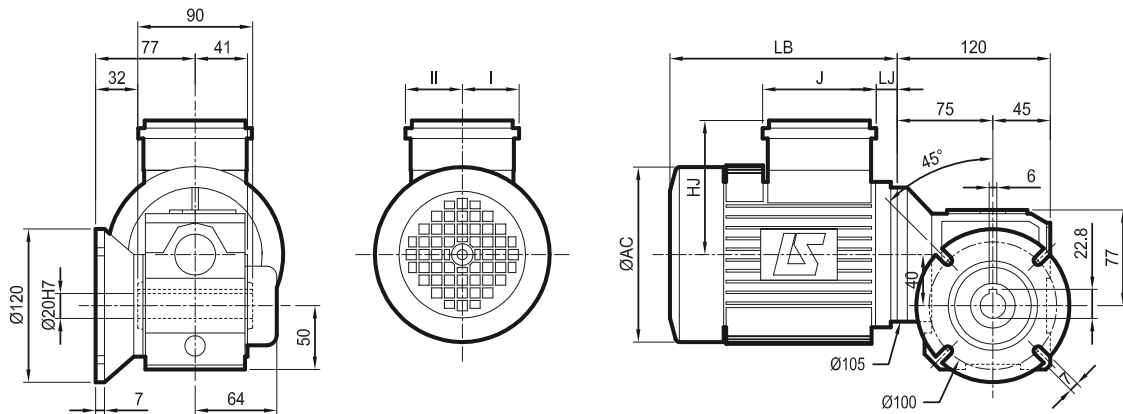

* option on right BNR H: identical flange and shaft

Type	4 poles motors										kg	4 poles motors										kg
	LSES MUT					LSES FCR MUT						LSES FCR MUT										
	AC	HJ	J	LB	LJ	PU	RU	I	II		AC	HJ	J	LB	LJ	PU	RU	I	II			
LS ES 80	171	135	86	267	67,5	105	0	43	43	11,7	172	146	160	304	13	105	0	55	55	18		

Type	4, 8 poles motors										kg	4, 8 poles motors										kg
	LS MUT					LS FCR MUT						LS FCR MUT										
	AC	HJ	J	LB	LJ	PU	RU	I	II		AC	HJ	J	LB	LJ	PU	RU	I	II			
LS 71 L	140	99	86	193	26	105	0	43	43	8,3	140	135	160	245	13	105	0	55	55	11		
LS 80 L	-	-	-	-	-	-	-	-	-	-	172	146	160	300	46	105	0	55	55	18		

Std CEI

Electromechanical products Multibloc

Dimensions

Dimensions of Multibloc (Mb) geared motors, MU universal mounting, Mb 2201 MUF LS

Dimensions in millimetres

- BD L* flange on left, H hollow shaft

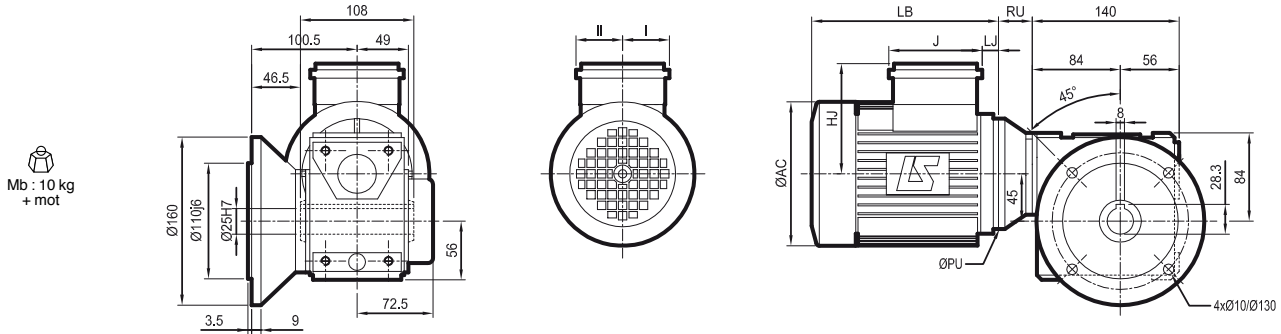

* option on right BDR H: identical flange and shaft

- NSD* baseplate, H hollow shaft

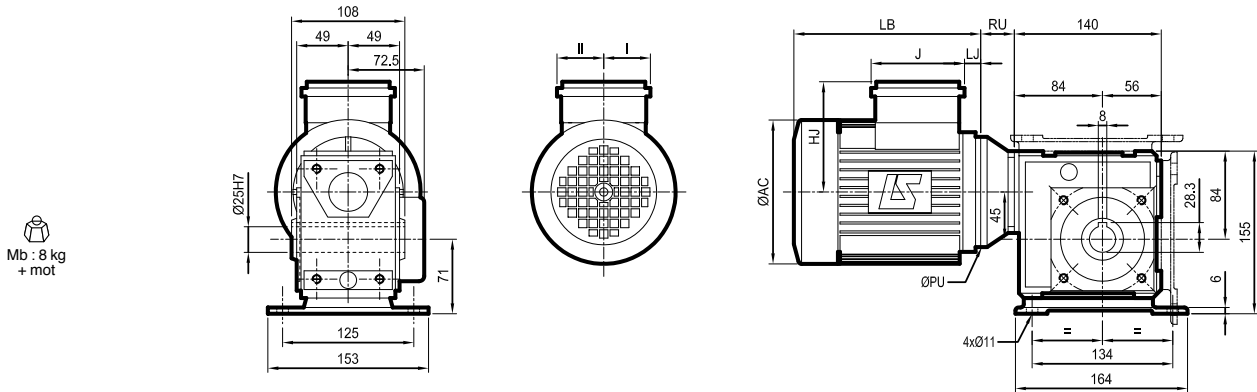

* NSF or NSU baseplate

- Flange details BN L

driven shaft

Details AP

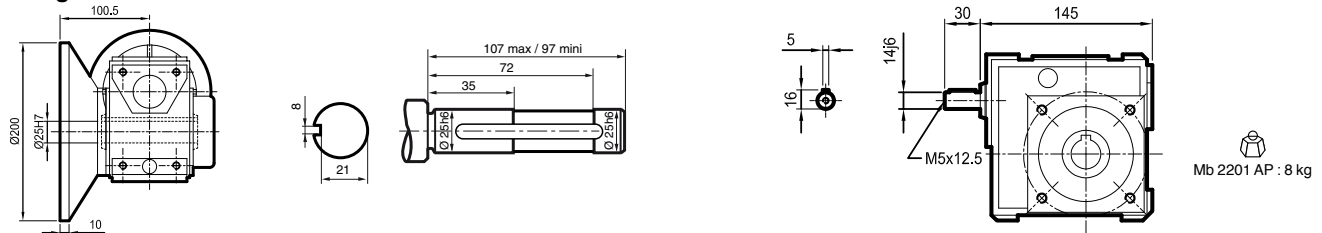

Type	LSES MUF										kg	LSES FCR MUF										kg
	AC	HJ	J	LB	LJ	PU	RU	I	II	kg		AC	HJ	J	LB	LJ	PU	RU	I	II	kg	
LSES 80	183	135	86	247	26	200	31	43	43	12,7	184	156	160	324	33	200	31	55	55	25,7		
LSES 90	190	135	86	290	71	200	31	43	43	15,2	184	156	160	324	33	200	31	55	55	25,7		

Type	LS 71 - 4 pole ; LS 80 - 8 pole MUF										kg	LS FCR MUF										kg
	AC	HJ	J	LB	LJ	PU	RU	I	II	kg		AC	HJ	J	LB	LJ	PU	RU	I	II	kg	
LS 71 L	140	99	86	193	26	160	24	43	43	9	140	135	160	271	38	160	24	55	55	12,5		
LS 80 L	170	123	86	215	26	200	31	43	60	10	172	146	160	292	40,5	200	31	55	55	19,7		
LS 90 L	-	-	-	-	-	-	-	-	-	-	184	156	160	324	33	200	31	55	55	25,7		

Std CEI

Electromechanical products

Multibloc

Dimensions

Dimensions of Multibloc (Mb) geared motors, MU universal mounting, Mb 2201 MUT LS

Dimensions in millimetres

- NU standard, H hollow shaft

Mb : 8 kg
+ mot

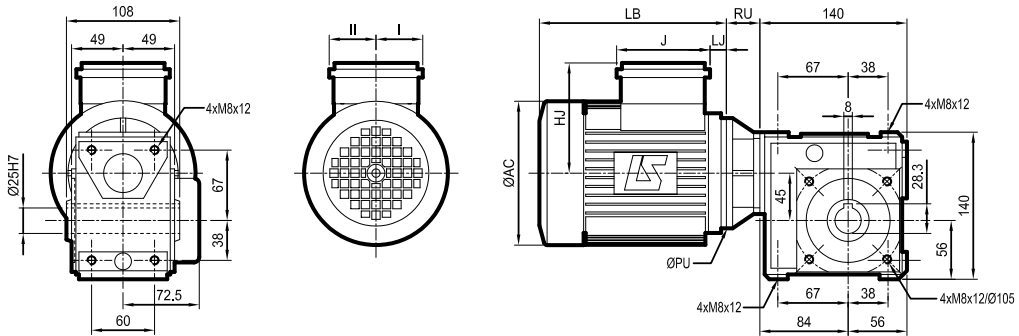

- BS¹ L* flange on left, H* hollow shaft

Mb : 11 kg
+ mot

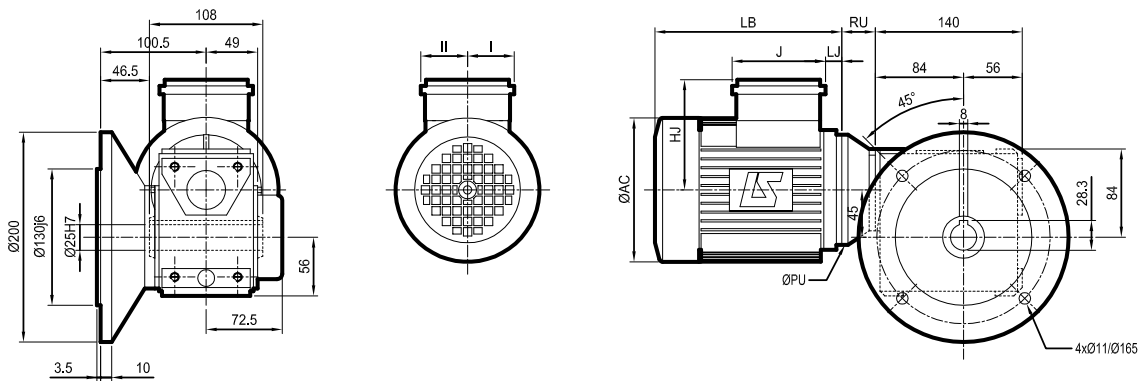

1. or BN flange: details page 20

* option on right BSR H: identical flange and shaft

Type	4 poles motors										kg	4 poles motors										kg
	LSES MUT					kg	LSES FCR MUT					kg										
	AC	HJ	J	LB	LJ		PU	RU	I	II			AC	HJ	J	LB	LJ	PU	RU	I	II	
LSES 80	183	135	86	267	26	120	33	43	43	12,7	184	156	160	304	13	120	33	55	55	25,2		
LSES 90	189	135	86	245	26	120	33	43	43	15,6	184	156	160	304	13	120	33	55	55	25,2		

Type	4, 8 poles motors										kg	4, 8 poles motors										kg
	LS 71 - 4 pole ; LS 80 - 8 pole MUT					kg	LS FCR MUT					kg										
	AC	HJ	J	LB	LJ		PU	RU	I	II			AC	HJ	J	LB	LJ	PU	RU	I	II	
LS 71 L	140	99	86	193	26	105	31	43	43	9	140	135	160	245	13	105	31	55	55	12		
LS 80 L	170	123	86	215	26	120	33	43	43	11,5	172	146	160	265	13	120	33	55	55	19,2		
LS 90 L	-	-	-	-	-	-	-	-	-	-	184	156	160	304	13	120	33	55	55	25,2		

Std CEI

Electromechanical products Multibloc

Dimensions

Dimensions of Multibloc (Mb) geared motors, MU universal mounting, Mb 2301 MUT LS

Dimensions in millimetres

- NU standard, H hollow shaft

Mb : 10,5 kg
+ mot

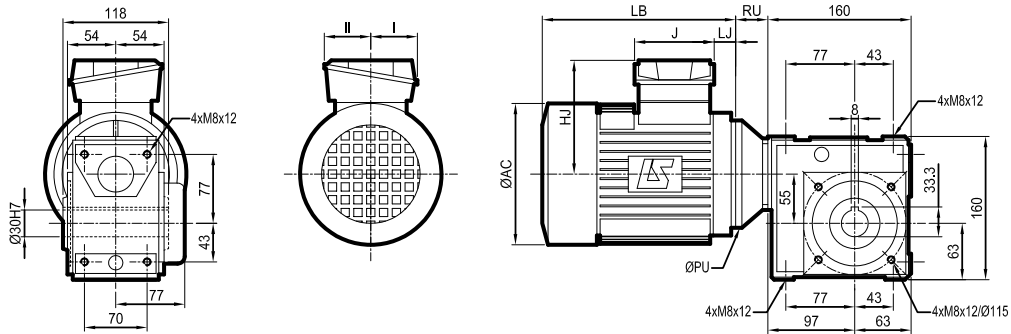

- BS¹ L* flange on left, H* hollow shaft

Mb : 14 kg
+ mot

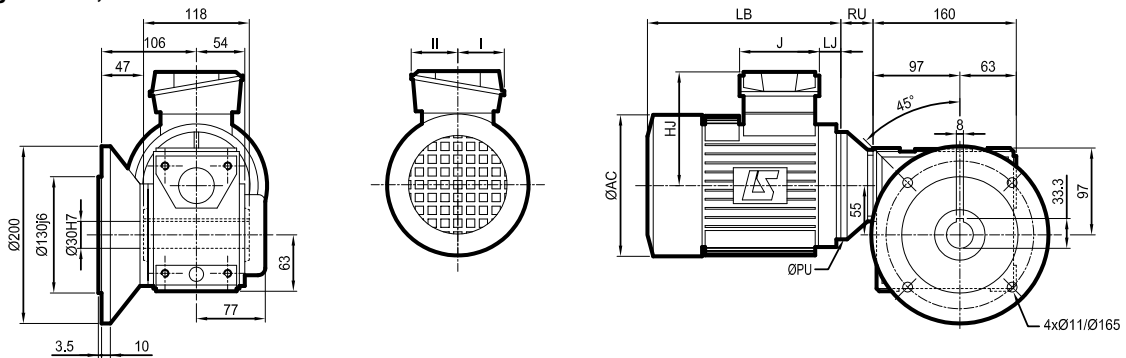

1. or BN flange: details page 22

* option on right BSR H: identical flange and shaft

4 poles motors

Type	LSES MUT									kg	LSES FCR MUT									kg
	AC	HJ	J	LB	LJ	PU	RU	I	II		AC	HJ	J	LB	LJ	PU	RU	I	II	
LSES 80	183	135	86	267	26	120	36	43	43	12,7	190	156	160	304	13	120	36	55	55	25,2
LSES 90	190	135	86	245	26	140	38	43	43	16,7	190	156	160	304	13	140	38	55	55	25,2
LSES 100	235	140	86	309	27	140	35	43	43	26,7	200	161	160	364,5	21	140	35	55	55	31
LSES 112	235	149	86	333	35,5	140	38	43	43	36	235	169	160	396	23,5	140	38	55	55	42

4, 8 poles motors

Type	LS 71 - 4 poles ; LS 80 and 90 - 8 poles MUT									kg	LS FCR MUT									kg
	AC	HJ	J	LB	LJ	PU	RU	I	II		AC	HJ	J	LB	LJ	PU	RU	I	II	
LS 71 L	140	99	86	193	26	105	35	43	43	9,2	140	135	160	245	13	105	35	55	55	12
LS 80 L	170	123	86	215	26	120	36	43	60	12	172	146	160	265	13	120	36	55	55	19,2
LS 90 L	190	133	86	245	26	140	36	43	60	16	190	156	160	304	13	140	38	55	55	25,2
LS 100 L	-	-	-	-	-	-	-	-	-	-	200	161	160	351	21	140	35	55	55	31
LS 112	-	-	-	-	-	-	-	-	-	-	235	169	160	396	23,5	140	38	55	55	42

Std CEI

Electromechanical products Multibloc

Dimensions

Dimensions of Multibloc (Mb) geared motors, MU universal mounting, Mb 2401 MUF LS

Dimensions in millimetres

- Bride to gauche BDL*, arbre creux H

Mb : 22 kg
+ mot

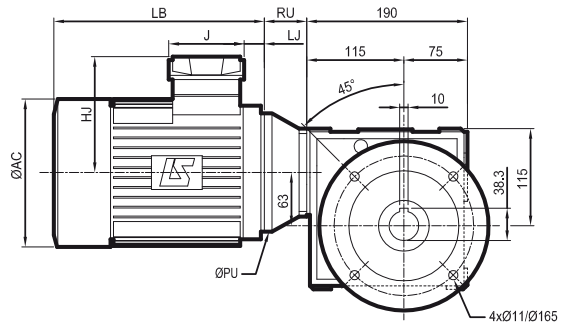
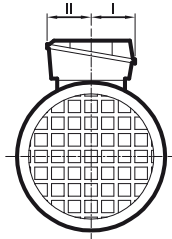
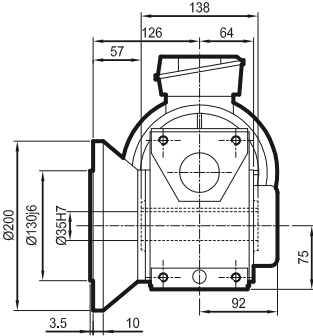

* option on right BDR H: identical flange and shaft

- NSD* baseplate, H hollow shaft

Mb : 18 kg
+ mot

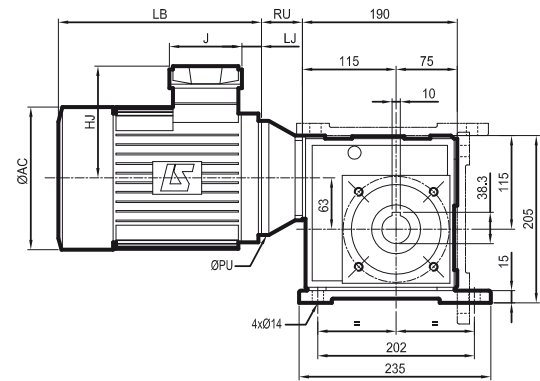
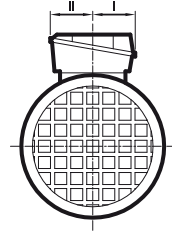
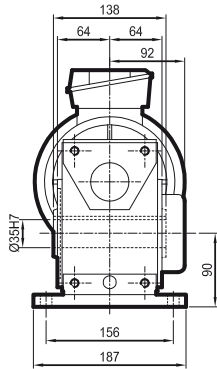

* NSF or NSU baseplate

- Flange details BN L

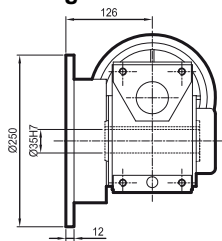

driven shaft

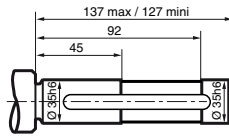

Details AP

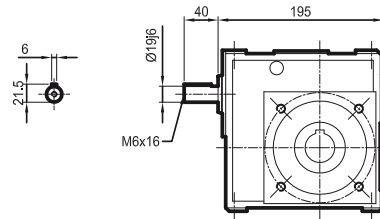

Mb 2401 AP : 17,5 kg

4 poles motors

Type	LSES MUF										kg	LSES FCR MUF										kg
	AC	HJ	J	LB	LJ	PU	RU	I	II			AC	HJ	J	LB	LJ	PU	RU	I	II		
LSES 80	183	135	86	247	26	200	50	43	43	14,7	184	156	160	324	33	200	50	55	55	27,2		
LSES 90	190	135	86	265	46	200	50	43	43	17,6	184	156	160	324	33	200	50	55	55	27,2		
LSES 100	235	140	86	309	27	250	50	43	43	28,7	200	161	160	400,5	50	250	50	55	55	33		
LSES 112	235	149	86	333	35,5	250	50	43	43	38	235	165	160	396	23,5	250	50	55	55	44		
LSES 132	220	172	126	377	32,5	250	50	63	63	45	235	169	160	457	41	250	50	55	55	51		

4, 8 poles motors

Type	LS 71 - 4 pole ; LS 8 pole MUF										kg	LS FCR MUF										kg
	AC	HJ	J	LB	LJ	PU	RU	I	II			AC	HJ	J	LB	LJ	PU	RU	I	II		
LS 71 L	140	99	86	193	21	160	50	43	43	11,3	140	135	160	271	38	160	50	55	55	14		
LS 80 L	170	123	86	215	26	200	50	43	60	14	172	146	160	292	38	200	50	55	55	21,2		
LS 90 L	190	133	86	265	46	200	50	43	60	18,2	184	156	160	324	33	200	50	55	55	27,2		
LS 100 L	200	138	86	290	26	250	50	43	60	25,5	200	161	160	388	50	250	50	55	55	33		
LS 112	-	-	-	-	-	-	-	-	-	-	235	169	160	425	49	250	50	55	55	44		
LS 132 S	-	-	-	-	-	-	-	-	-	-	235	169	160	437	41	250	50	55	55	51		

Std CEI

Electromechanical products

Multibloc

Dimensions

Dimensions of Multibloc (Mb) geared motors, MU universal mounting,
Mb 2401 MUT LS

Dimensions in millimetres

- NU standard, H hollow shaft

 Mb : 17,5 kg
+ mot

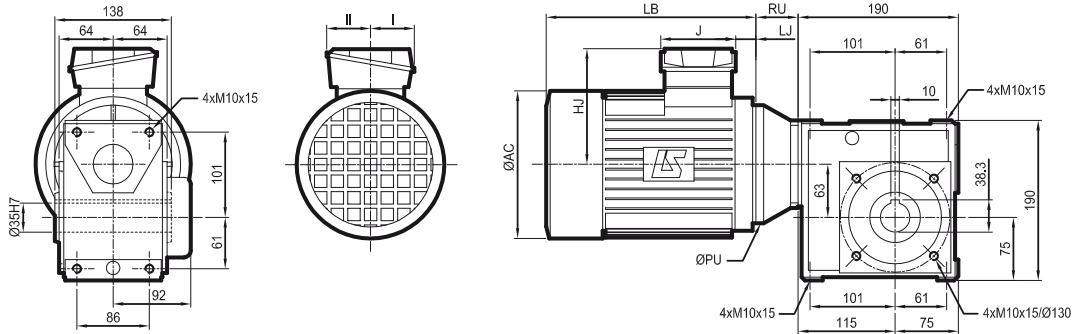

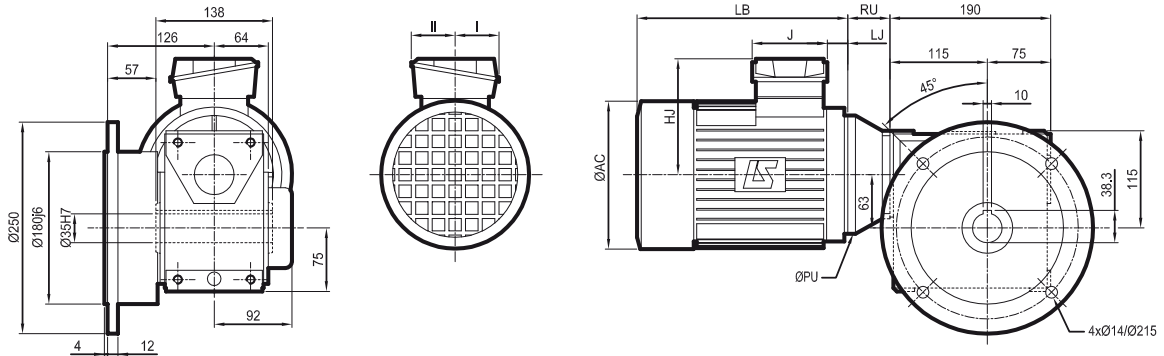

- BS¹ L* flange on left, H* hollow shaft

 Mb : 23 kg
+ mot



1. or BN flange: details page 24
* option on right BSR H: identical flange and shaft

Type	4 poles motors										 kg									
	LSES MUT					LSES FCR MUT														
	AC	HJ	J	LB	LJ	PU	RU	I	II	AC		HJ	J	LB	LJ	PU	RU	I	II	
LSES 80	183	135	86	267	26	120	50	43	43	13,5	184	156	160	304	13	120	50	55	55	26
LSES 90	190	135	86	245	26	140	50	43	43	16,4	184	156	160	304	13	140	50	55	55	26
LSES 100	235	140	86	309	27	160	50	43	43	27,5	200	161	160	364,5	21	160	50	55	55	31,8
LSES 112	235	149	86	333	35,5	160	50	43	43	36,8	235	169	160	396	23	160	50	55	55	42,8
LSES 132	220	172	126	377	32	160	50	63	63	43,8	235	169	160	457	41	160	50	55	55	43,8

Type	4, 8 poles motors										 kg									
	LS 8 pole MUT					LS FCR MUT														
	AC	HJ	J	LB	LJ	PU	RU	I	II	AC		HJ	J	LB	LJ	PU	RU	I	II	
LS 80 L	170	123	86	215	26	120	50	43	60	12,7	172	146	160	265	13	120	50	55	55	20
LS 90 L	190	133	86	245	26	140	50	43	60	17	184	156	160	304	13	140	50	55	55	26
LS 100 L	200	138	86	290	26	160	50	43	60	24,3	200	161	160	351	21	160	50	55	55	31,8
LS 112	-	-	-	-	-	-	-	-	-	-	235	169	160	396	23	160	50	55	55	42,8
LS 132 S	-	-	-	-	-	-	-	-	-	-	235	169	160	437	41	160	50	55	55	43,8

Std CEI

Electromechanical products

Multibloc

Dimensions

Dimensions of Multibloc (Mb) geared motors, MU universal mounting,
Mb 2501 MUT LS

Dimensions in millimetres

- NU standard, H hollow shaft

Mb : 31 kg
+ mot

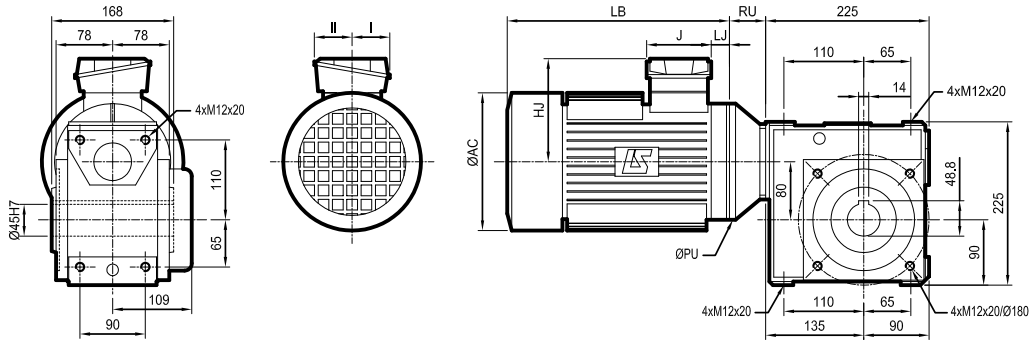

- BS¹ L* flange on left, H* hollow shaft

Mb : 38 kg
+ mot

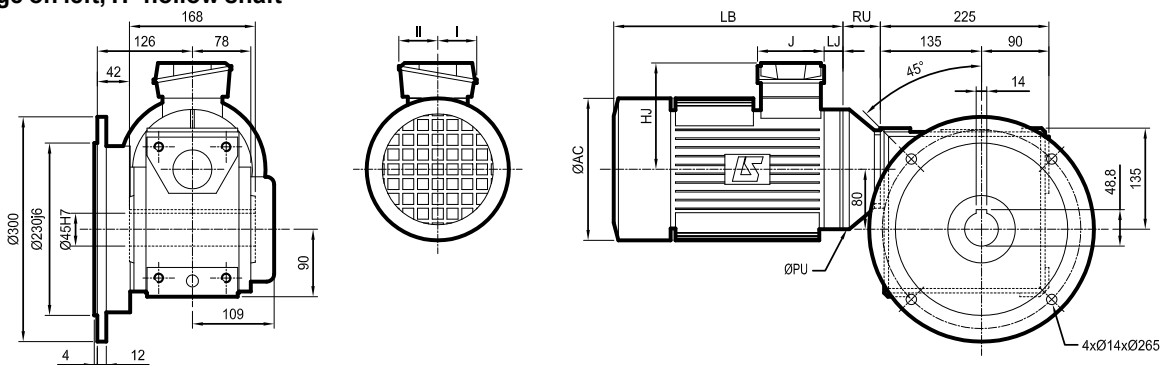

1. or BN flange: details page 26
* option on right BSR H: identical flange and shaft

4 poles motors

Type	LSES MUT										kg	LSES FCR MUT										kg
	AC	HJ	J	LB	LJ	PU	RU	I	II			AC	HJ	J	LB	LJ	PU	RU	I	II		
LSES 80	183	135	86	247	26	120	50	43	43	13,5	190	156	160	304	13	120	50	55	55	26		
LSES 90	190	135	86	245	26	140	50	43	43	16,4	190	156	160	304	13	140	50	55	55	26		
LSES 100	235	140	86	309	27	160	50	43	43	27,5	200	161	160	363,5	21	160	50	55	55	31,8		
LSES 112	235	149	86	333	35,5	160	50	43	43	36,8	235	169	160	396	23	160	50	55	55	42,8		
LSES 132	265	190	126	412	17	160	50	43	43	69,8	280	188	160	493	25	160	50	55	55	76,8		

4, 8 poles motors

Type	LS 8 pole MUT										kg	LS FCR MUT										kg
	AC	HJ	J	LB	LJ	PU	RU	I	II			AC	HJ	J	LB	LJ	PU	RU	I	II		
LS 80 L	-	-	-	-	-	-	-	-	-	-	172	146	160	265	13	120	50	55	55	20		
LS 90 L	190	133	86	245	26	140	50	43	60	17	184	156	160	304	13	140	50	55	55	26		
LS 100 L	200	138	86	290	26	160	50	43	60	24,3	200	161	160	351	21	160	50	55	55	31,8		
LS 112	200	138	86	290	26	160	50	43	60	26,7	235	169	160	396	23	160	50	55	55	42,8		
LS 132	-	-	-	-	-	-	-	-	-	-	280	188	160	493	25	160	50	55	55	76,8		

Std CEI

Electromechanical products Multibloc

Dimensions

Dimensions of Multibloc (Mb) geared motors, MU universal mounting, Mb 2601 MUT LS

Dimensions in millimetres

- NU standard, H hollow shaft

Mb : 37 kg
+ mot

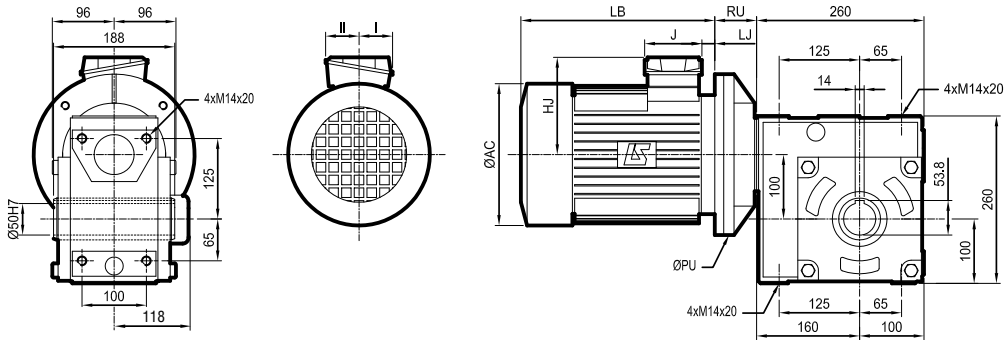

- BS¹ L* flange on left, H* hollow shaft

Mb : 47 kg
+ mot

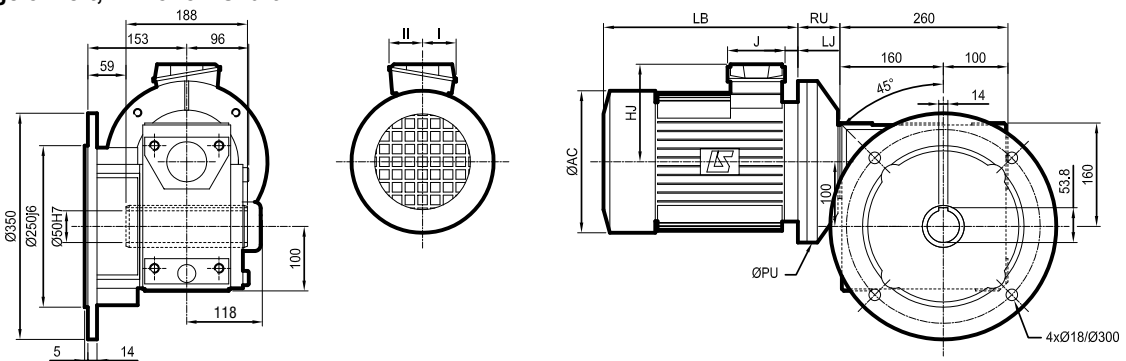

1. or BN flange: details page 26 * option on right BSR H: identical flange and shaft

- BT* form, H* hollow shaft

Mb : 40 kg
+ mot

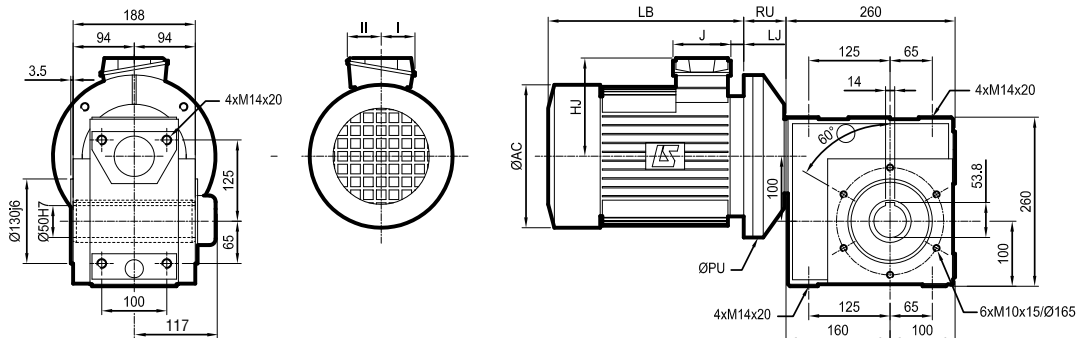

* option

4 poles motors

Type	LSES MUT										kg	LSES FCR MUT										kg
	AC	HJ	J	LB	LJ	PU	RU	I	II	AC		HJ	J	LB	LJ	PU	RU	I	II			
LS 100	235	140	86	309	27	250	51	43	43	29,2	200	161	160	363,5	21	250	51	55	55	33,5		
LS 112	235	149	86	333	35,5	250	51	43	43	38,5	235	169	160	396	23	250	51	55	55	44,5		
LS 132	265	190	126	412	17	250	51	63	63	71,5	280	188	160	493	25	250	51	55	55	78,5		

4, 8 poles motors

Type	LS 8 pole MUT										kg	LS FCR MUT										kg
	AC	HJ	J	LB	LJ	PU	RU	I	II	AC		HJ	J	LB	LJ	PU	RU	I	II			
LS 100L	200	138	86	290	26	250	51	43	60	26	200	161	160	351	21	250	51	55	55	33,5		
LS 112	200	138	86	290	26	250	51	43	60	28,4	235	169	160	396	23	250	51	55	55	44,5		
LS 132	280	175	110	387	25	250	51	57	73	63,5	280	188	160	493	25	250	51	55	55	78,5		

Std CEI

Electromechanical products

Multibloc

Dimensions

Dimensions of Multibloc (Mb) geared motors, MU universal mounting, Mb 3101

Dimensions in millimetres

- BN1 L* flange on left, HL* output shaft on left

Mb : 6 kg
+ mot

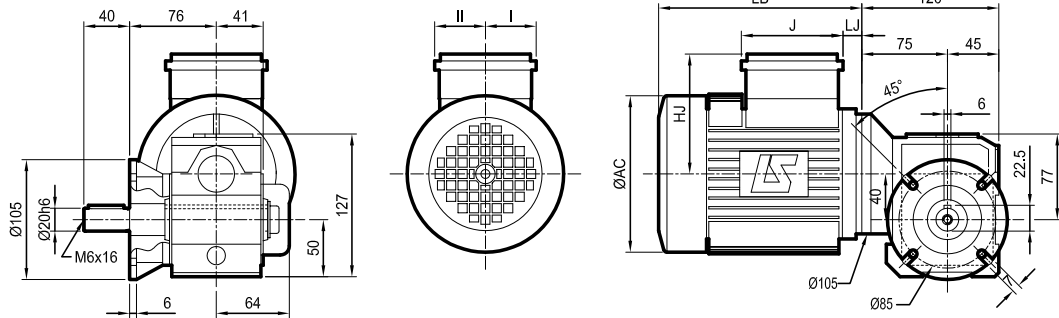

* option on right BN1 R HR: identical flange and shaft

- BN2 L* flange on left, HL* output shaft on left

Mb : 6.5 kg
+ mot

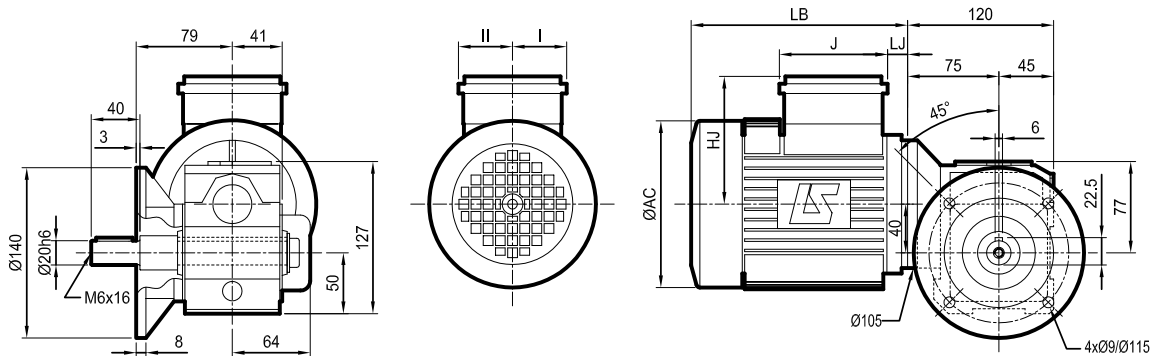

* option on right BN2 R RH: identical flange and shaft

- Details HLR

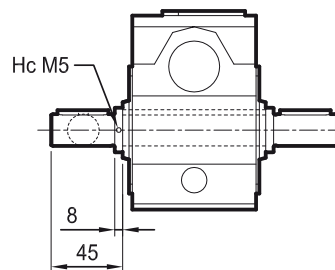

Electromechanical products

Multibloc

Dimensions

Dimensions of Multibloc (Mb) geared motors, MU universal mounting, Mb 3101 MUT LS

Dimensions in millimetres

- NU standard, HL¹ output shaft on left

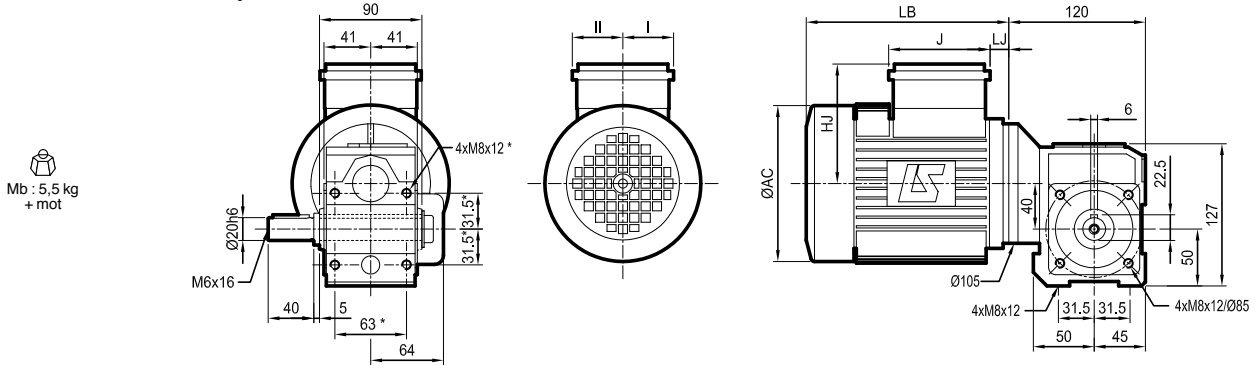

- BN¹ L* flange on left, HL* output shaft on left

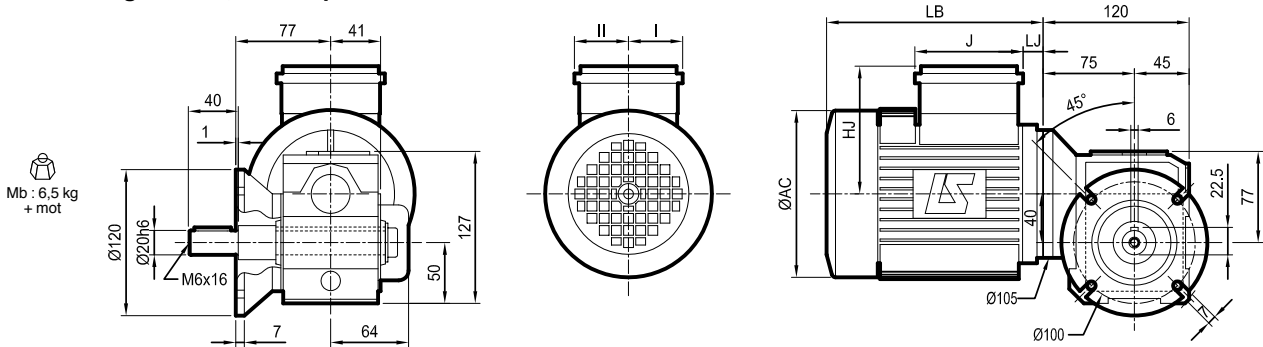

* option on right BNR HR: identical flange and shaft

Type	4 poles motors										kg	4 poles motors										kg				
	LSES MUT					LSES FCR MUT						LSES FCR MUT					LSES FCR MUT									
	AC	HJ	J	LB	LJ	PU	RU	I	II	AC		HJ	J	LB	LJ	PU	RU	I	II	AC	HJ		J	LB	LJ	PU
LSES 80	171	135	86	267	67,5	105	0	43	43	11,7	172	146	160	304	13	105	0	55	55	18						

Type	4, 8 poles motors										kg	4, 8 poles motors										kg				
	LS MUT					LS FCR MUT						LS FCR MUT					LS FCR MUT									
	AC	HJ	J	LB	LJ	PU	RU	I	II	AC		HJ	J	LB	LJ	PU	RU	I	II	AC	HJ		J	LB	LJ	PU
LS 71 L	140	99	86	193	26	105	0	43	43	8,3	140	135	160	245	13	105	0	55	55	11						
LS 80 L	-	-	-	-	-	-	-	-	-	-	172	146	160	300	46	105	0	55	55	18						

Std CEI

Electromechanical products

Multibloc

Dimensions

Dimensions of Multibloc (Mb) geared motors, MU universal mounting,
Mb 2201 MUF LS

Dimensions in millimetres

- BD L* flange on left, HL* output shaft on left

Mb : 11 kg
+ mot

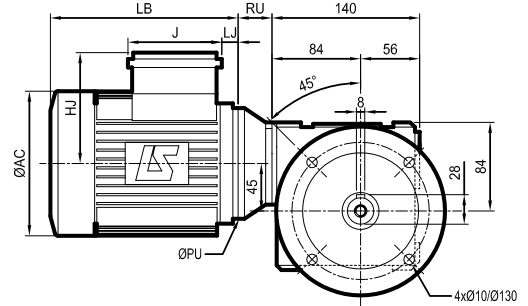
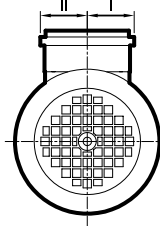
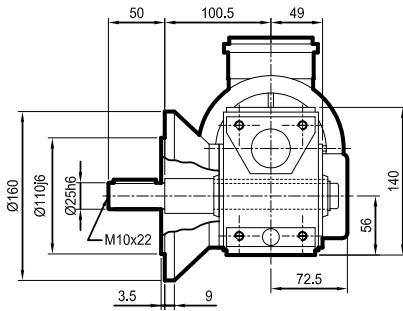

* option on right BDR HR: identical flange and shaft

- NSD* baseplate, HL¹ output shaft on left

Mb : 9 kg
+ mot

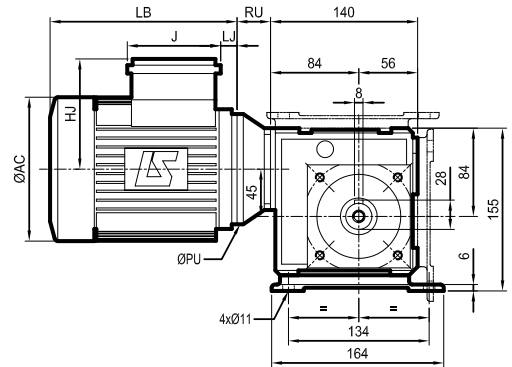
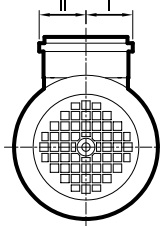
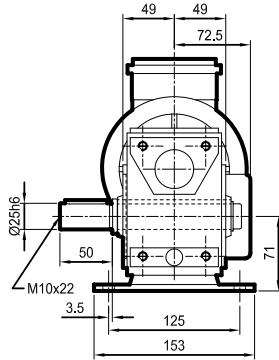

* NSF or NSU baseplate, see details
1. option: HR shaft on right

- Details

BN L

NSF

NSU

HLR

Details AP

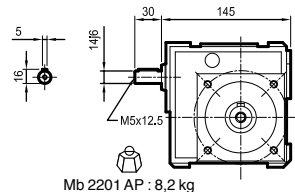
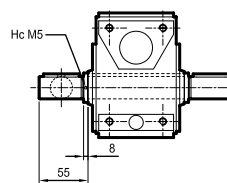
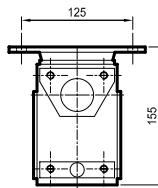
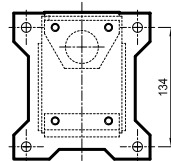
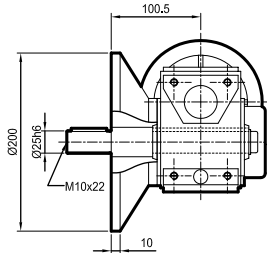

4 poles motors

Type	LSES MUF										kg	LSES FCR MUF										kg
	AC	HJ	J	LB	LJ	PU	RU	I	II			AC	HJ	J	LB	LJ	PU	RU	I	II		
LSES 80	183	135	86	247	26	200	31	43	43	12,7	184	156	160	324	33	200	31	55	55	25,7		
LSES 90	190	135	86	290	71	200	31	43	43	15,2	184	156	160	324	33	200	31	55	55	25,7		

4, 8 poles motors

Type	LS 71 - 4 poles ; LS 80 - 8 poles MUF										kg	LS FCR MUF										kg
	AC	HJ	J	LB	LJ	PU	RU	I	II			AC	HJ	J	LB	LJ	PU	RU	I	II		
LS 71 L	140	99	86	193	26	160	24	43	43	9	140	135	160	271	38	160	24	55	55	12,5		
LS 80 L	170	123	86	215	26	200	31	43	60	10	172	146	160	292	40,5	200	31	55	55	19,7		
LS 90 L	-	-	-	-	-	-	-	-	-	-	184	156	160	324	33	200	31	55	55	25,7		

Std CEI

Electromechanical products Multibloc

Dimensions

Dimensions of Multibloc (Mb) geared motors, MU universal mounting, Mb 2301 MUF LS

Dimensions in millimetres

- BD L* flange on left, HL* output shaft on left

Mb : 14 kg
+ mot

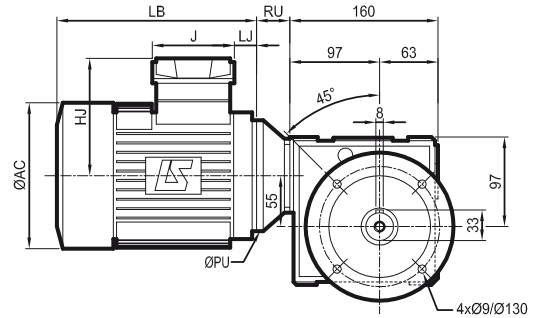
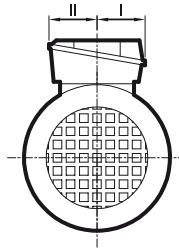
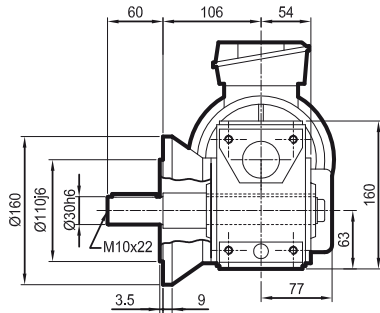

* option on right BDR HR: identical flange and shaft

- NSD* baseplate, HL¹ output shaft on left

Mb : 12,5 kg
+ mot

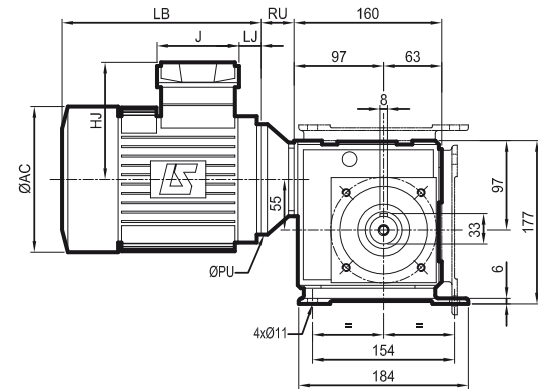
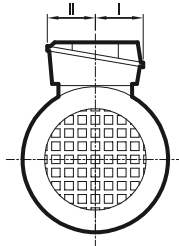
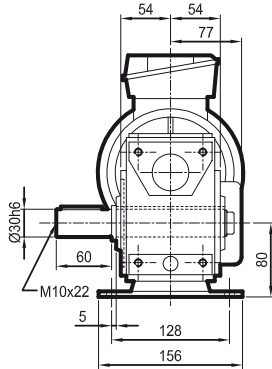

* NSF or NSU baseplate, see details
1. option: HR shaft on right

- Details

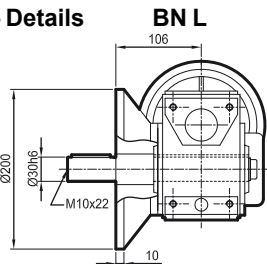

NSF

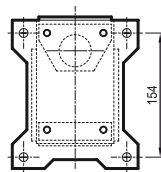

NSU

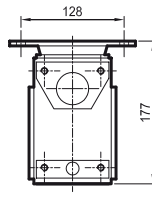

HLR

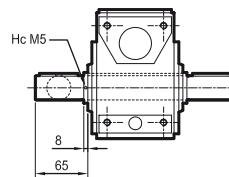

Details AP

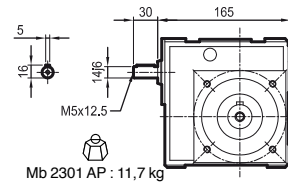

4 poles motors

Type	LSES MUF										kg	LSES FCR MUF										kg
	AC	HJ	J	LB	LJ	PU	RU	I	II			AC	HJ	J	LB	LJ	PU	RU	I	II		
LS 80	183	135	86	247	26	200	31	43	43	13,2	184	156	160	324	33	200	31	55	55	25,7		
LS 90	190	135	86	265	46	200	31	43	43	16,1	184	156	160	324	33	200	31	55	55	25,7		
LS 100	235	140	86	309	27	200	31	43	43	27,2	200	161	160	400,5	50	200	31	55	55	31,5		
LS 112	235	149	86	333	35,5	200	31	43	43	36,5	235	165	160	396	23,5	200	31	55	55	42,5		

4, 8 poles motors

Type	LS 71 - 4 poles ; LS 80 and 90 - 8 poles MUF										kg	LS FCR MUF										kg
	AC	HJ	J	LB	LJ	PU	RU	I	II			AC	HJ	J	LB	LJ	PU	RU	I	II		
LS 71 L	140	99	86	193	26	160	24	43	43	9,8	140	135	160	271	38	160	24	55	55	12,5		
LS 80 L	170	123	86	215	26	200	31	43	60	12,4	172	146	160	292	40,5	200	31	55	55	19,7		
LS 90 L	190	133	86	265	46	200	31	43	60	16,7	184	156	160	324	33	200	31	55	55	25,7		
LS 100 L	-	-	-	-	-	-	-	-	-	-	200	161	160	388	50	200	31	55	55	31,5		
LS 112	-	-	-	-	-	-	-	-	-	-	235	165	160	396	23,5	200	31	55	55	42,5		

Std CEI

Electromechanical products

Multibloc

Dimensions

Dimensions of Multibloc (Mb) geared motors, MU universal mounting, Mb 2401 MUT LS

Dimensions in millimetres

- NU standard, HL¹ output shaft on left

Mb : 19,3 kg
+ mot

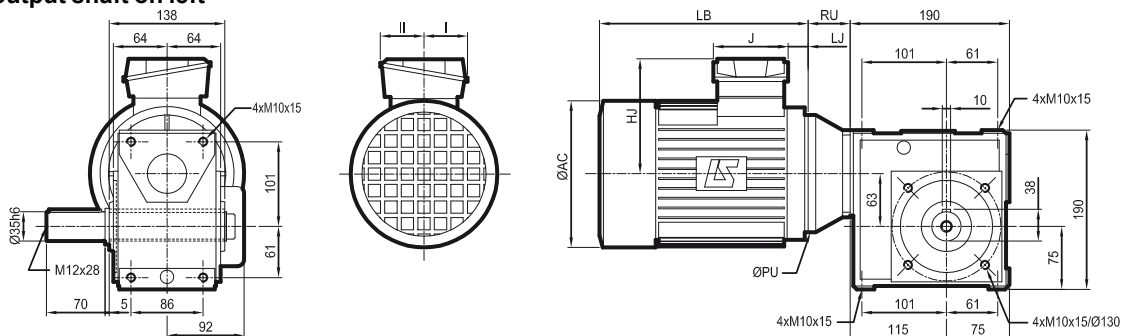

1. option: HR shaft on right

- BS¹ L* flange on left, HL* output shaft on left

Mb : 24,9 kg
+ mot

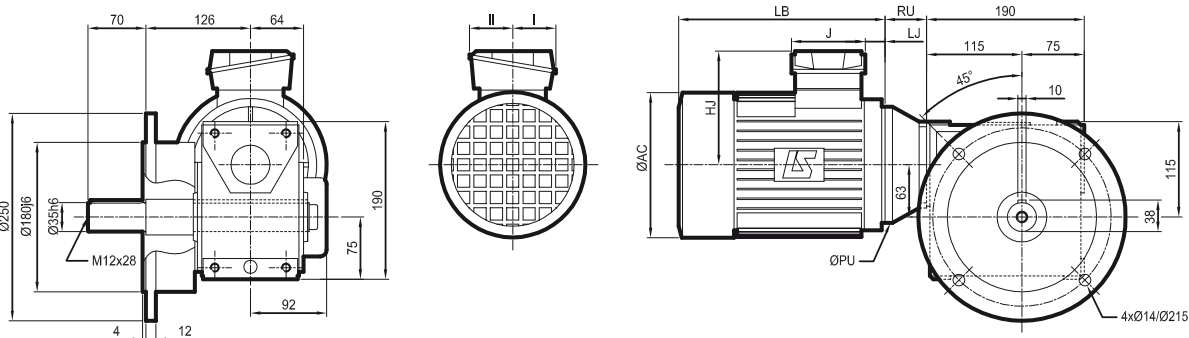

1. or BN flange: details page 36

* option on right BSR HR: identical flange and shaft

4 poles motors

Type	LSES MUT										kg	LSES FCR MUT										kg
	AC	HJ	J	LB	LJ	PU	RU	I	II			AC	HJ	J	LB	LJ	PU	RU	I	II		
LSES 80	183	135	86	267	26	120	50	43	43	13,5	184	156	160	304	13	120	50	55	55	26		
LSES 90	190	135	86	245	26	140	50	43	43	16,4	184	156	160	304	13	140	50	55	55	26		
LSES 100	235	140	86	309	27	160	50	43	43	27,5	200	161	160	364,5	21	160	50	55	55	31,8		
LSES 112	235	149	86	333	35,5	160	50	43	43	36,8	235	169	160	396	23	160	50	55	55	42,8		
LSES 132	220	172	126	377	32	160	50	63	63	43,8	235	169	160	457	41	160	50	55	55	43,8		

4, 8 poles motors

Type	LS 8 poles MUT										kg	LS FCR MUT										kg
	AC	HJ	J	LB	LJ	PU	RU	I	II			AC	HJ	J	LB	LJ	PU	RU	I	II		
LS 80 L	170	123	86	215	26	120	50	43	60	12,7	172	146	160	265	13	120	50	55	55	20		
LS 90 L	190	133	86	245	26	140	50	43	60	17	184	156	160	304	13	140	50	55	55	26		
LS 100 L	200	138	86	290	26	160	50	43	60	24,3	200	161	160	351	21	160	50	55	55	31,8		
LS 112	-	-	-	-	-	-	-	-	-	-	235	169	160	396	23	160	50	55	55	42,8		
LS 132 S	-	-	-	-	-	-	-	-	-	-	235	169	160	437	41	160	50	55	55	43,8		

Std CEI

Electromechanical products Multibloc

Dimensions

Dimensions of Multibloc (Mb) geared motors, MU universal mounting, Mb 2501 MUF LS

Dimensions in millimetres

- BDL* flange on left, HL* output shaft on left

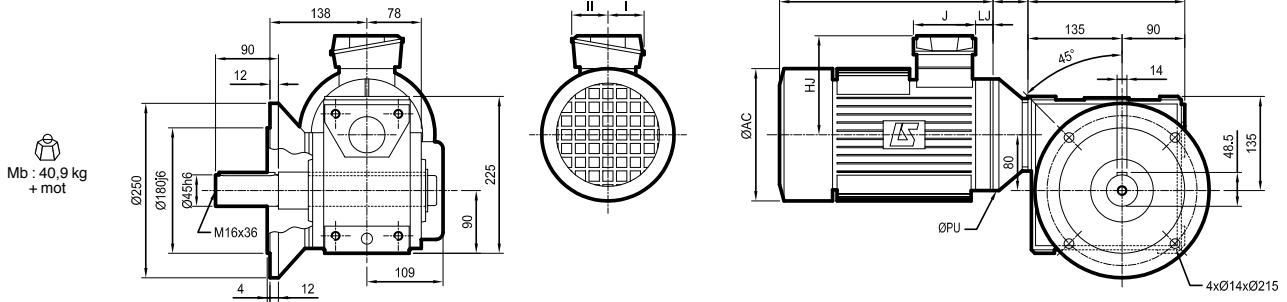

- NSD* baseplate, HL¹ output shaft on left

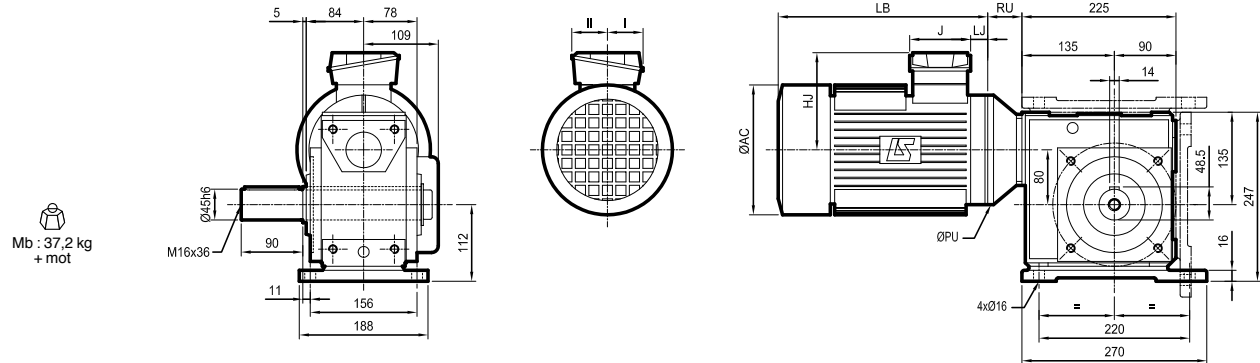

- Details

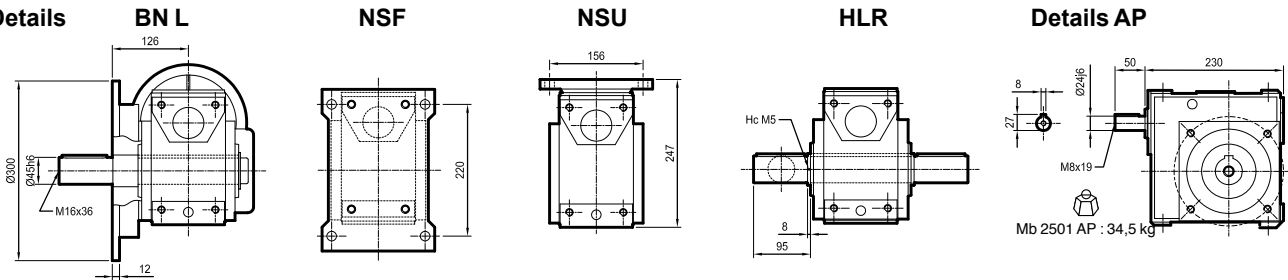

4 poles motors

Type	LSES MUF										kg	LSES FCR MUF										kg
	AC	HJ	J	LB	LJ	PU	RU	I	II			AC	HJ	J	LB	LJ	PU	RU	I	II		
LSES 80	183	135	86	247	26	200	50	43	43	14,7	184	156	160	324	38	200	50	55	55	27,2		
LSES 90	190	135	86	265	46	200	50	43	43	17,6	184	156	160	324	33	200	50	55	55	27,2		
LSES 100	235	140	86	309	27	250	50	43	43	28,7	200	161	160	400,5	50	250	50	55	55	33		
LSES 112	235	149	86	333	35,5	250	50	43	43	38	235	169	160	425	49	250	50	55	55	44		
LSES 132	265	190	126	412	17	250	50	63	63	71	280	188	160	533	65	250	50	55	55	78		

4, 8 poles motors

Type	LS 8 pole MUF										kg	LS FCR MUF										kg
	AC	HJ	J	LB	LJ	PU	RU	I	II			AC	HJ	J	LB	LJ	PU	RU	I	II		
LS 80 L	-	-	-	-	-	-	-	-	-	-	172	146	160	292	38	200	50	55	55	21,2		
LS 90 L	190	133	86	265	46	200	50	43	60	18,4	184	156	160	324	33	200	50	55	55	27,2		
LS 100 L	200	138	86	290	26	250	50	43	60	25,6	200	161	160	388	50	250	50	55	55	33		
LS 112	200	138	86	290	26	250	50	43	60	27,9	235	169	160	425	49	250	50	55	55	44		
LS 132	-	-	-	-	-	-	-	-	-	-	280	188	160	533	65	250	50	55	55	78		

Std CEI

Electromechanical products

Multibloc

Dimensions

Dimensions of Multibloc (Mb) geared motors, MU universal mounting, Mb 2501 MUT LS

Dimensions in millimetres

- NU standard, HL¹ output shaft on left

Mb : 34,5 kg + mot

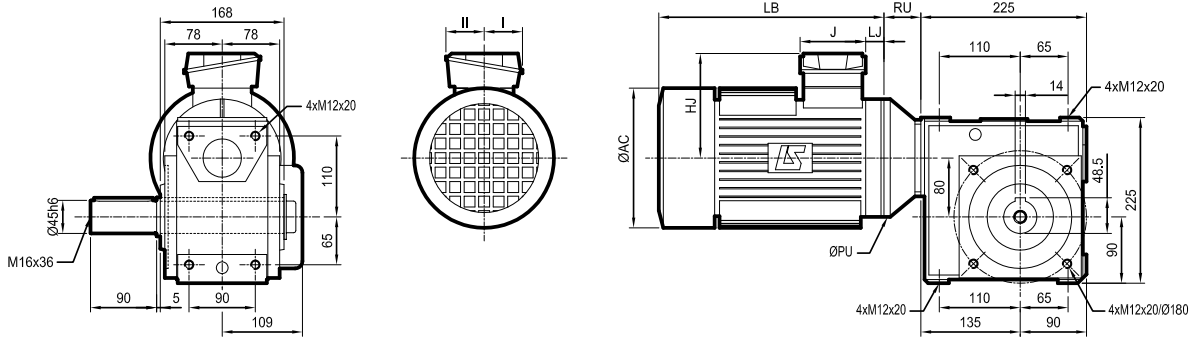

1. option: HR shaft on right

- BS¹ L* flange on left, H* hollow shaft

Mb : 41,7 kg + mot

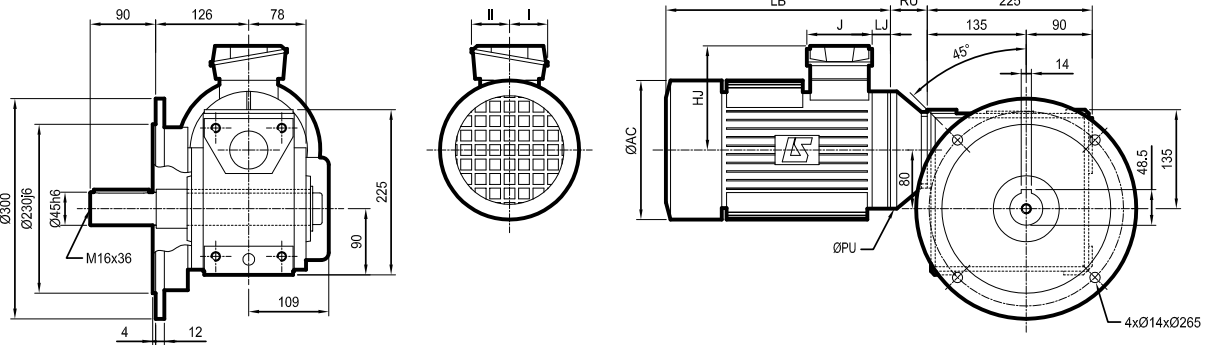

1. or BN flange: details page 38

* option on right BSR HR: identical flange and shaft

Type	4 poles motors																			
	LSES MUT					kg	LSES FCR MUT					kg								
	AC	HJ	J	LB	LJ		PU	RU	I	II										
LSES 80	183	135	86	247	26	120	50	43	43	13,5	190	156	160	304	13	120	50	55	55	26
LSES 90	190	135	86	245	26	140	50	43	43	16,4	190	156	160	304	13	140	50	55	55	26
LSES 100	235	140	86	309	27	160	50	43	43	27,5	200	161	160	363,5	21	160	50	55	55	31,8
LSES 112	235	149	86	333	35,5	160	50	43	43	36,8	235	169	160	396	23	160	50	55	55	42,8
LSES 132	265	190	126	412	17	160	50	43	43	69,8	280	188	160	493	25	160	50	55	55	76,8

Type	4, 8 poles motors																			
	LS 8 pole MUT					kg	LS FCR MUT					kg								
	AC	HJ	J	LB	LJ		PU	RU	I	II										
LS 80 L	-	-	-	-	-	-	-	-	-	-	172	146	160	265	13	120	50	55	55	20
LS 90 L	190	133	86	245	26	140	50	43	60	17	184	156	160	304	13	140	50	55	55	26
LS 100 L	200	138	86	290	26	160	50	43	60	24,3	200	161	160	351	21	160	50	55	55	31,8
LS 112	200	138	86	290	26	160	50	43	60	26,7	235	169	160	396	23	160	50	55	55	42,8
LS 132	-	-	-	-	-	-	-	-	-	-	280	188	160	493	25	160	50	55	55	76,8

Std CEI

Electromechanical products Multibloc

Dimensions

Dimensions of Multibloc (Mb) geared motors, MU universal mounting, Mb 2601 MUF LS

Dimensions in millimetres

- BDL* flange on left, HL* output shaft on left

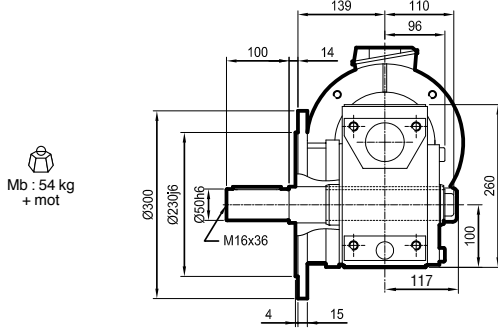

Mb : 54 kg
+ mot

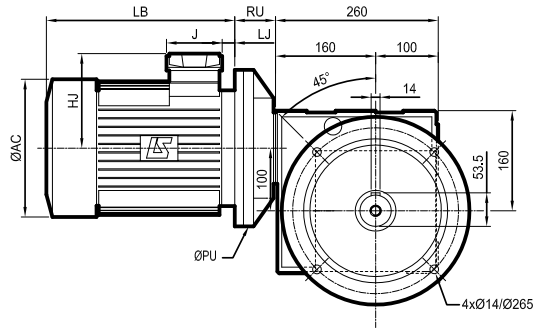
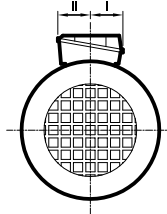

* option on right BDR HR: identical flange and shaft

- NSD* baseplate, HL¹ output shaft on left

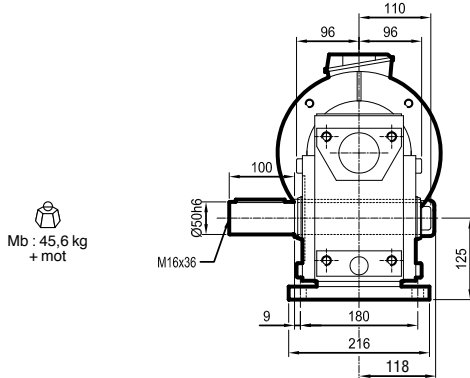

Mb : 45.6 kg
+ mot

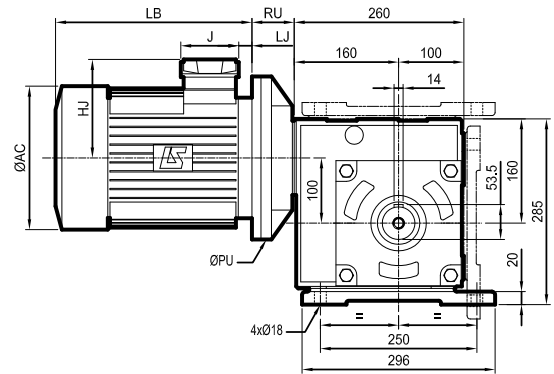
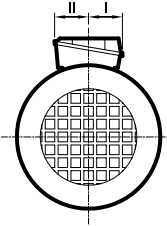

* NSF or NSU baseplate, see details 1. option : HR shaft on right

- Details

BN L

NSF

NSU

HLR

Details AP

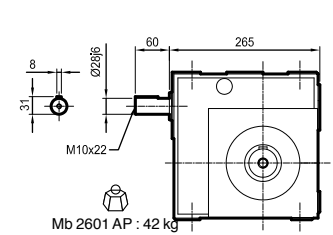
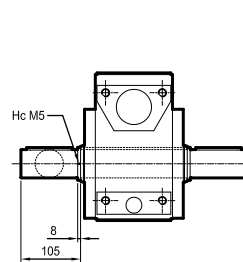
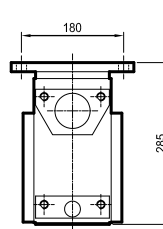
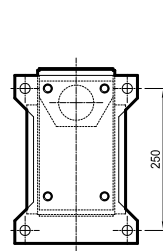
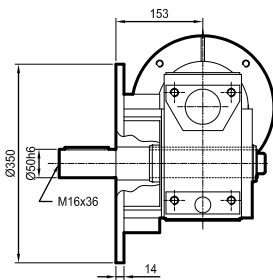

4 poles motors

Type	LSES MUF										kg	LSES FCR MUF										kg
	AC	HJ	J	LB	LJ	PU	RU	I	II			AC	HJ	J	LB	LJ	PU	RU	I	II		
LSSES 90	190	135	86	265	46	200	59	43	43	18,2	184	156	160	324	33	200	59	55	55	27,8		
LSSES 100	235	140	86	309	27	250	51	43	43	29,3	200	161	160	400,5	50	250	51	55	55	33,6		
LSSES 112	235	149	86	333	35,5	250	51	43	43	38	235	169	160	425	49	250	51	55	55	44,6		
LSSES 132	265	190	126	452	57	250	51	63	63	71	280	188	160	533	65	250	51	55	55	78,6		

4, 8 poles motors

Type	LS 8 pole MUF										kg	LS FCR MUF										kg
	AC	HJ	J	LB	LJ	PU	RU	I	II			AC	HJ	J	LB	LJ	PU	RU	I	II		
LS 90L	190	133	86	265	46	200	59	43	60	18,8	184	156	160	324	33	200	59	55	55	27,8		
LS 100L	200	138	86	290	26	250	51	43	60	26	200	161	160	388	50	250	51	55	55	33,6		
LS 112	200	138	86	290	26	250	51	43	60	28,5	235	169	160	425	49	250	51	55	55	44,6		
LS 132	280	175	110	387	25	250	51	57	73	63,5	280	188	160	533	65	250	51	55	55	78,6		

Std CEI

Electromechanical products

Multibloc

Dimensions

Dimensions of R torque arm, Mb 3101 and Mb 2201 to Mb 2601

Dimensions in millimetres

- Mb 2201 to 2601: R LD form (or R RD)

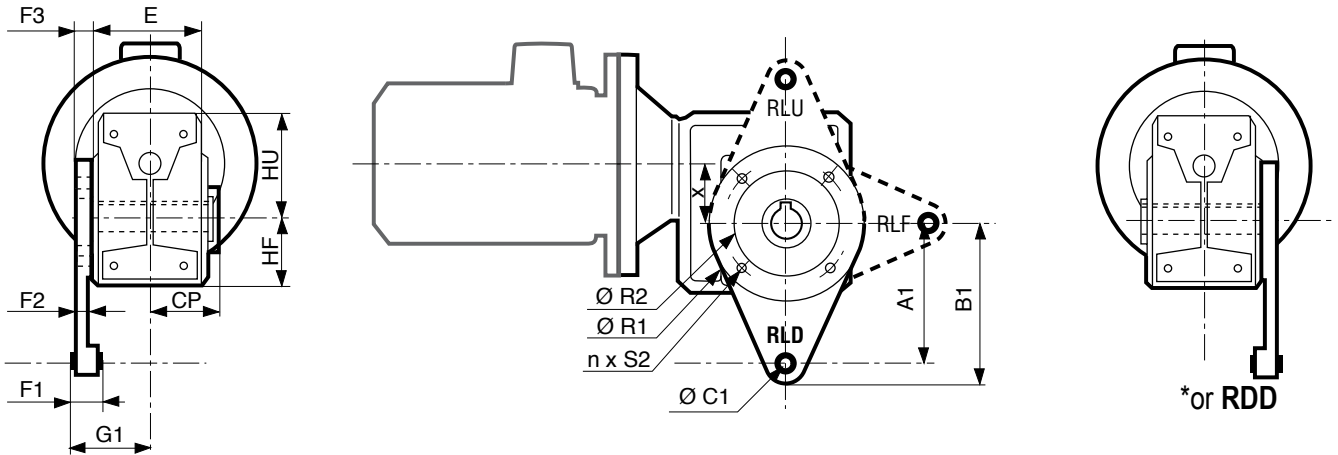

- Mb 3101: R LD form (or R RD)

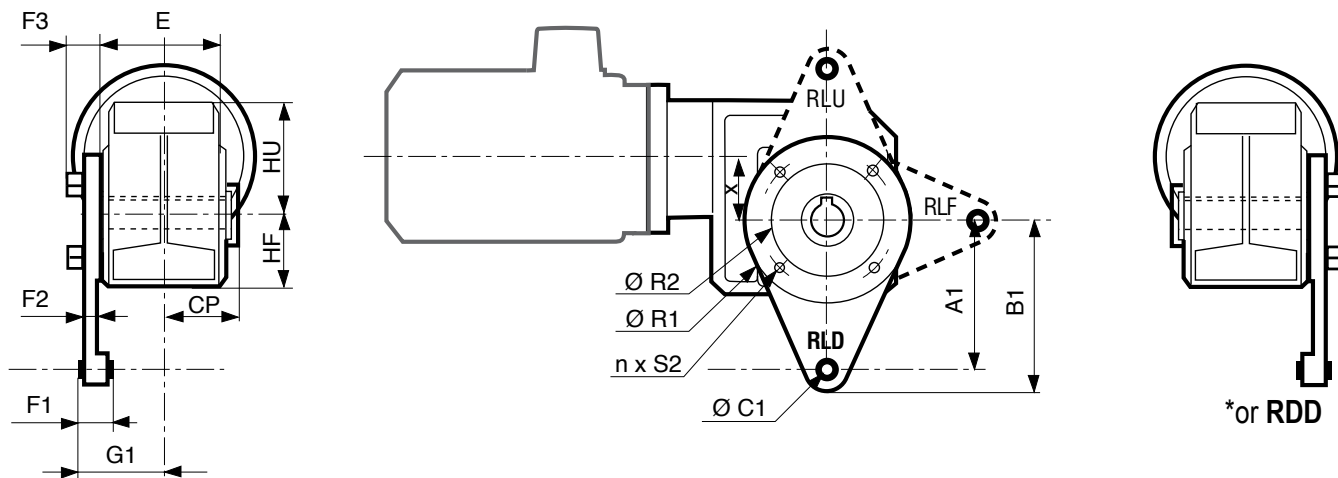

Type ¹	R torque arm																kg
	A1	B1	CP	C1	E	F1	F2	F3	G1	HF	HU	R1	R2	n	S2	x	
Mb 2601	250	280	-	16 H10	188	54	12	22	106	100	160	190	134	6	M10 x 15	100	3,6
Mb 2501	310	340	28,5	16 H10	168	54	23	25	105	90	135	225	135	4	M12 x 25	80	6,7
Mb 2401	200	230	28	16 H10	138	54	23	25	91	75	115	179	97	4	M10 x 25	63	4,3
Mb 2301	160	181	22,5	10 H10	118	33	14	16	71,5	63	97	153	86	4	M8 x 15	55	1,8
Mb 2201	130	151	23,5	10 H10	108	33	14	16	66,5	56	84	133	77	4	M8 x 15	45	1,4
Mb 3101	100	120	22,5	10 H10	90	23	6	11,5	48,5	50	70	109	68	4	M8 x 20	40	0,5

1. In standard version, the torque arm (fitted with a flexible Silentbloc shock mount) is supplied separately, painted in black.
Optionally, the torque arm is supplied mounted on the gearbox: in this case specify **R** (right) or **L** (left) mounting side and **D**, **F** or **U** orientation.

I - SCOPE OF APPLICATION

These General Conditions of Sale («GCS») shall apply to the sale of all products, components, software and services (referred to as «Products») proposed or sold by the Seller to the Client. Said GCS shall also apply to all quotation or offers made by the Seller, and are an integral part of all orders. «Seller» is understood to mean all companies directly or indirectly controlled by LEROY-SOMER. As a complementary measure, orders are also subject to the latest version in force of the Inter-Union General Conditions of Sale for France of the F.I.E.E.C. (*Fédération des Industries Electriques, Electroniques et de Communication* [Federation of Electrical, Electronic and Communication Industries]), inasmuch as they are not contrary to the GCS.

The acceptance of the Seller's offers or quotations, or any order, entails the acceptance without reservation of these GCS and rules out all contrary provisions shown on all other documents and, in particular, on the Client's order forms and the Client's General Conditions of Purchase. If the sale concerns castings, by way of derogation to Paragraph 1 above, said castings shall be subject to the latest version in force of the *Conditions Générales Contractuelles des Fonderies Européennes* [General Contractual Conditions of European Foundries].

The Products and services sold pursuant to these GCS may under no circumstances be used for applications in the nuclear field, as such sales expressly fall under technical specifications and specific contracts that the Seller reserves the right to refuse.

II - ORDERS

All orders, even those taken by the Seller's agents and representatives, and regardless of the transmission method, shall only bind the Seller after written acceptance thereby of the order.

The Seller reserves the option of modifying the characteristics of its Products without notice. However, the Client shall retain the possibility of specifying the characteristics on which its commitment is contingent. In the absence of any such express stipulation, the Client may not refuse delivery of new, modified Products.

The Seller may not be held liable for an unsatisfactory selection of Products if said selection results from conditions of use that are incomplete and/or mistaken, or not disclosed to the Seller by the Client. Except in the event of a stipulation to the contrary, the offers and quotations remitted by the Seller shall only be valid for thirty days as from the date on which they are drawn up.

Where the Products must comply with standards, specific regulations and/or be received by control and inspection agencies, the price request must be accompanied by the technical specification, all terms and conditions the Seller must comply with. Reference shall be made thereto on the quotation or offer. Approval and attendance costs shall always be borne by the Client.

III - PRICES

Tariffs are expressed exclusive of tax and may be revised without notice. Prices are either deemed to be firm for the period of validity specified on the quotation, or subject to a revision formula attached to the offer and which specifies, according to the regulations, parameters pertaining to the materials, products, various services and salaries for which the indices are published in the B.O.C.C.R.F. (*Bulletin Officiel de la Concurrence, de la Consommation et de la Répression des Fraudes* [French Official Journal of Competition and Consumer Matters, and Anti-Fraud Measures]). All additional costs, in particular approval costs, specific checks, etc., shall be invoiced in addition.

IV - DELIVERY

Sales are governed by the latest edition in force of the INCOTERMS published by the Internal Chamber of Commerce («I.C.C. INCOTERMS»).

The Products shall be dispatched according to the conditions stated on the order acknowledgement issued by the Seller for all orders of Products.

Except in the event of specific provisions, the prices correspond to Products that are made available in the Seller's factories, including basic packaging.

Except in the event of a provision to the contrary, the Products shall always be transported at the risk of the addressee. In all cases, it shall be the responsibility of the addressee to make any claims to the carrier, within the delivery time and in the forms specified by law, concerning the state or number of parcels received, and to concomitantly provide the Seller with a copy of such declaration. Failure to comply with said procedure shall exempt the Seller from any liability. In any event, the Seller's liability may not exceed the amount of the indemnities received from its insurers.

If the provisions concerning transportation are amended by the Client subsequent to the acceptance of the order, the Seller reserves the right to invoice any supplemental costs that may result therefrom. Except in the event of a contractual or statutory obligation to the contrary, packaging shall not be returnable.

In the event that a delivery of Products is delayed for a reason not attributable to the Seller, the Products stored on the Seller's premises shall be insured at the exclusive risk of the Client. Consideration for storage, costs will be invoiced at a rate of 1% (*one per cent*) of the total amount of the order, per week or partial week of storage, with no deductible or *de minimis* amount, as from the date of Products availability provided for in the contract. Upon expiration of a period of thirty days as from said date, the Seller may, at its discretion, either freely dispose of the Products and/or agree with the Client on a new delivery date for said Products, or invoice the Client in full for payment, according to the timeframes and amount provided for contractually. In any event, down payments shall inure to the Seller as indemnities, without prejudice to any other action the Seller may take.

V - DELIVERY TIME

The Seller shall only be bound by the delivery time mentioned on its order acknowledgement. Said delivery time shall only start to run as from the date of issuance of the order acknowledgement by the Seller, and subject to the fulfilment of the conditions provided for on the confirmation receipt, in particular receipt of the down payment for the order, notification of the opening of an operative irrevocable and confirmed documentary credit that complies in all respects to the Seller's request (*in particular regarding the amount, currency, validity and licence*), acceptance of the payment conditions accompanied by the implementation of any guarantees requested, etc.

Exceeding delivery time shall not grant the Client entitlement to damages and/or penalties.

Except in the event of a specific condition to the contrary, the Seller reserves the right to make partial deliveries. Delivery times shall be interrupted by right and without the need for any judicial formalities, by any failure to pay or late payment by the Client.

VI - TESTS - QUALIFICATION

The Products manufactured by the Seller are checked and tested before leaving its factories. Clients may be present at said tests if specified on the order.

Specific tests and/or trials, as well as approval of Products, requested by the Client, whether carried out on the Client's premises or in the Seller's factories, on site, or by control and inspection agencies, must be specified on the order and are always at Client's expense.

Prototypes for Products specially developed or adapted for a Client must be qualified by the Client before serial production in order to ensure that it is compatible with the other components that make up its equipment, and that it is adapted to the intended use. Said qualification will also enable the Client to ensure that the Products comply with the technical specification. In this respect, the Client and Seller shall sign a Product Approval Form in two original, one of which shall be retained by the Client and one by the Seller.

In the event that the Client requires delivery without having firstly qualified the Products, said Products shall be delivered as they stand and

shall always be deemed to be prototypes; the Client shall then be solely liable for using the Products or delivering them to its own clients. However, the Seller may also decide not to deliver the Products that have not received the Client's prior approval.

VII - PAYMENT CONDITIONS

All sales shall be deemed to be completed and payable at the Seller's registered office, without any possible derogation, regardless of the payment method, where the contract was concluded and where delivery was made.

Where the Client is located out of French territory, invoices shall be payable in cash upon receipt, or by a bank draft or a bill of exchange, within 30 (thirty) days net.

All early payment compared to the deadline fixed shall give right to a discount of 0.2% (*nought point two per cent*) per month, of the amount concerned of the invoice.

Except in the event of provisions to the contrary, where the Client is located outside of French Territory, invoices shall be payable in cash against remittance of shipping documents, or by irrevocable documentary credit confirmed by a first rate French bank, at Client's expense.

Payment shall be understood to mean the funds being made available on the Seller's bank account and must imperatively be made in the invoicing currency.

Pursuant to French Law no. 2008-776 of 4 August 2008, failure to pay an invoice when due shall trigger, after service of formal notice that has remained without effect, payment to the Seller of a flat-rate penalty on the due date of the receivable, which shall be applied to amount inclusive of tax of monies owed if the invoice is liable to VAT (*Value Added Tax*), and the suspension of pending orders. Said penalty is equal to the European Central Bank interest rate on the main refinancing operations + 10 basis points.

The collection of said monies via litigation shall trigger an increase of 15% (*fifteen per cent*) of the amount claimed, with a minimum of Euros 500 exclusive of tax (*five hundred euros exclusive of tax*), with tax in addition if due.

Moreover, subject to compliance with the statutory provisions in force, in the event of total or partial failure to pay any invoice or instalment whatsoever, regardless of the payment method used, all amounts that remain owed to the Seller (*including its subsidiaries, affiliated or allied companies, whether French or foreign*) for all deliveries and services, regardless of the due date originally provided for, shall immediately become due.

Notwithstanding any specific payment conditions provided for between the parties, the Seller reserves the right to require, in the event of a decline in the Client's credit rating, a payment incident or bankruptcy of the Client:

- the payment in cash, before the Products leave the factory, for all orders currently being fulfilled,
- down payments to be made on all orders,
- alternative or different payment guarantees.

VIII - PAYABLE AND RECEIVABLE BALANCE

Except where prohibited by law, the Seller and the Client expressly agree to balance their payables and receivables arising from their trade relations, even if all conditions defined by law for legal balancing are not met.

For the application of said clause, the Seller shall mean any company of the LEROY-SOMER Group.

IX - TRANSFER OF RISK / RESERVE OF TITLE

Risk shall be transferred as soon as the Products are made available, according to the delivery conditions stipulated on the order acknowledgement.

The transfer to the Client of title shall take place after payment in full. In the event that the restitution of the Products delivered is claimed by the Seller, the Seller is entitled to retain any down payment as compensation.

Remittance of a bill that creates an obligation to pay (*bill of exchange or other*) shall not constitute payment and discharge. For as long as the price has not been paid in full, the Client is required to inform the Seller, within twenty-four hours, of the sequestration, requisition or confiscation of the Products for the benefit of a third party, and to take all protective measures to make known the Seller's property right in the event of action by creditors, and to cause such right to be respected.

X - CONFIDENTIALITY

Each of the parties undertakes to maintain the confidentiality of all technical, trade, financial or other information received from the other party, whether orally, in writing or by any other means of communication, when any order is negotiated and/or fulfilled.

This confidentiality obligation shall apply throughout the period during which the order is fulfilled and for 5 (five) years subsequent to completion or cancellation thereof, regardless of the reasons therefor.

XI - INDUSTRIAL AND INTELLECTUAL PROPERTY

Data, studies, results, information or software, whether patentable or not obtained by the Seller when any order is fulfilled shall remain the exclusive property of the Seller.

With the exception of instruction and maintenance manuals, documents of any nature remitted to the Client shall remain the exclusive property of the Seller and must be returned to it upon request, even if the Client was invoiced for part of the cost of the study, and said documents may not be disclosed to third parties or used without the Seller's prior written agreement.

XII - CANCELLATION / TERMINATION

The Seller reserves the right to cancel or terminate immediately, at the Seller's discretion, by right and without the need for any judicial formalities, the contract in the event of failure to pay any portion whatsoever of the price, when due, or in the event of any breach of any of the Client's contractual obligations. Down payments and any amount already paid shall remain in Seller's hands in the form of indemnities, without prejudice to the Seller's right to claim damages. In the event that the contract is cancelled, the Products must be returned to the Seller immediately, regardless of where the Products are located, at Client's expense and risk, under penalty of 10% (*ten per cent*) of the value thereof, per week's delay.

XIII - WARRANTY

The Seller warrants the Products against all operating defects caused by a material or manufacturing fault, for a period of twelve months as from the date on which the Products are made available, unless a different statutory provision subsequently applies, under the conditions defined below.

The warranty may only be triggered insofar as the Products have been stored, used and maintained in accordance with the Seller's instructions and manuals. The warranty does not apply where the defect results, in particular, from:

- inadequate monitoring, maintenance or storage,
 - normal wear and tear on the Products,
 - servicing or modification of the Products without the Seller's prior written authorisation,
 - abnormal use of the Products or use of the Products for a purpose other than that intended,
 - faulty installation of the Products on the premises of the Client and/or the end user,
 - failure by the Client to disclose the purpose or conditions of use of the Products,
 - failure to use genuine spare parts,
 - force majeure or any event that is beyond the control of the Seller.
- In any case, the warranty is limited to the replacement or repair of the

parts or Products deemed faulty by the Seller's technical departments. If the repair is entrusted to a third party, the repair shall only be carried out once the Seller has agreed to the quotation for the repair.

All Products returns must have been given the Seller's prior, written authorisation.

The Products to be repaired must be dispatched carriage paid, to the address given by the Seller. If the Products are not accepted under warranty, their return to the Client shall be invoiced to the Client or the end user.

This warranty shall apply to the Seller's Products that are made readily available and therefore does not cover the de-installation and re-installation of said Products in the equipment into which it is mounted. Repair, modification or replacement of any part or Product during the warranty period may not result in the warranty period being extended.

The provisions of this article constitute the Seller's sole obligation concerning the warranty of the Products delivered.

XIV - LIABILITY

The Seller's liability is strictly limited to the obligations stipulated in these GCS and those expressly accepted by the Seller. All penalties and indemnities provided for therein constitute lump sum damages that include discharge for the Seller and are exclusive of any other penalty or indemnification.

With the exception of the Seller's gross negligence and the compensation of bodily injury, the Seller's liability shall be limited, in total, to the contractual amount, exclusive of tax, of the Product(s) that give(s) right to compensation.

The Seller may under no circumstances be required to indemnify consequential, indirect and / or punitive damages that the Client may use as the basis for a claim; as a result, the Seller may not be required to indemnify, in particular, production losses, operating losses or lost profit or, in general, any damage eligible for indemnification other than bodily injury or damage to property.

The Client undertakes to hold harmless the Seller and / or its insurers from any and all claims made by its insurers and/or any third party in a contractual relation with the Client, in excess of the limit and for the exclusions listed above.

XV - SPARE PARTS AND ACCESSORIES

Spare parts and accessories shall be supplied upon request, to the extent of their availability. Associated costs shall be invoiced in addition. The Seller reserves the right to require a minimum quantity or invoicing amount per order.

XVI - WASTE MANAGEMENT

The Products that form the purpose of the sale does not fall within the scope of the European Directive 2002/96/EC (WEEE) dated January 27th, 2003, and all related legislation of Member States of the European Union that result therefrom, on the composition of electrical and electronic equipment and the disposal of waste from such equipment. In accordance with Article L 541-2 of the French Environment Code, it is the responsibility of the waste holder to ensure the disposal thereof or to cause the disposal thereof at its own expense.

XVII - FORCE MAJEURE

With the exception of the Client's obligation to pay the monies owed to the Seller in respect of an order, the Client and Seller may not be held liable for the total or partial failure to perform their contractual obligations if such failure results from the occurrence of a force majeure. Delays or disturbances in production that totally or partially result from war (whether declared or not), terrorist act, strikes, riots, accidents, fires, floods, natural disasters, transportation delays, shortage of components or materials, governmental decision or action (including prohibition on import/export or the withdrawal of an import/export licence) shall, in particular, be deemed a force majeure.

If one of the parties is delayed or prevented from performing its obligations by reason of this Article for a period in excess of 180 consecutive days, each party may then terminate, by right and without any need for judicial formalities, the unperformed part of the order, by written notice to the other party, without liability. However, the Client shall be required to pay the price agreed pertaining to the Products already delivered on the date of termination.

XVIII - PROHIBITION ON UNLAWFUL PAYMENTS

The Client shall refrain from being engaged in any activity that would expose the Seller or any of its affiliates to a risk of penalties under laws and regulations of any relevant jurisdiction prohibiting improper payments, including but not limited to bribes or gifts of an obviously unreasonable amount, to any government or agency officials, to political parties or their officials or candidates for public office, or to any employee of any customer or supplier.

XIX - TRADE COMPLIANCE LAWS

The Client agrees that all applicable import, export control and sanctions laws, regulations, orders and requirements, as they may be amended from time to time, including without limitation those of the European Union, the United States of America, and the jurisdictions in which the Seller and the Client are established or from which Products may be supplied, and the requirements of any licences, authorisations, general licences or licence exceptions relating thereto ("Trade Compliance Laws") will apply to its receipt and use of Products, as well as related services and technology. In no event shall the Client use, transfer, release, export or re-export the Products, related services or technology in violation of Trade Compliance Laws.

Seller shall have no obligation to supply any Products, or services unless and until it has received any necessary licences or authorisations or has qualified for general licences or licence exceptions under Trade Compliance Laws.

If for any reason any such licences, authorisations or approvals are denied or revoked, or if there is a change in any Trade Compliance Laws that would prohibit Seller from fulfilling the contract, or would in the reasonable judgement of Seller otherwise expose Seller and/or Seller's Affiliate(s) to a risk of liability under Trade Compliance Laws, Seller shall be relieved without liability of all obligations under the contract.

XX - SEVERABILITY

All clauses and/or provisions of these General Conditions that are deemed or become null or void shall not cause the nullity or voidance of the contract, but solely the clause and/or provision concerned.

XXI - DISPUTES

THIS CONTRACT SHALL BE GOVERNED BY AND INTERPRETED IN ACCORDANCE WITH THE LAWS OF FRANCE.

ANY DISPUTE IN RELATION TO THE INTERPRETATION OR THE EXECUTION OF THIS CONTRACT NOT AMICABLY SETTLED BETWEEN THE PARTIES WITHIN A 30 DAY PERIOD, SHALL BE SETTLED BY THE COMPETENT COURT OF ANGOULÊME (FRANCE), EVEN IN THE CASE OF INTRODUCTION OF THIRD PARTIES OR THE INVOLVEMENT OF SEVERAL DEFENDANTS. HOWEVER, THE SUPPLIER RESERVES THE EXCLUSIVE RIGHT TO BRING THE DISPUTE TO THE COMPETENT COURTS OF THE SELLER OR THE CLIENT.

International network

www.leroy-somer.com

ALGERIA
LEROY-SOMER INTERNATIONAL DIVISION

AUSTRALIA
LEROY-SOMER PTY LTD

AUSTRIA
LEROY-SOMER ELEKTROMOTOREN

BELGIUM
LEROY-SOMER BELGIUM

BRAZIL
LEROY-SOMER DIVISION
EMERSON ELECTRIC DO BRASIL LTDA.

CANADA
LEROY-SOMER / EMC

CHINA
LEROY-SOMER DIVISION

CROATIA
EMERSON NETWORK POWER LTD

CZECH REPUBLIC
M.L.S. HOLICE S.R.O.

DENMARK
LEROY-SOMER DENMARK A/S

EGYPT
MOTEURS LEROY-SOMER

FRANCE
MOTEURS LEROY-SOMER

GERMANY
LEROY-SOMER MARBAISE GMBH

GREECE
LEROY-SOMER LTD

HUNGARY
LEROY-SOMER I.M.I.

INDIA
LEROY-SOMER C/O EMERSON ELECTRIC CO.

ITALIA
LEROY-SOMER SPA

JAPAN
LEROY-SOMER DIVISION
EMERSON JAPAN LTD.

KOREA
EMERSON ELECTRIC KOREA

MOROCCO
CARREFOUR INDUSTRIEL ET TECHNOLOGIQUE

NETHERLANDS
LEROY-SOMER NEDERLAND B.V

POLAND
FZN MARBAISE LS

ROMANIA
LEROY-SOMER DIVISION

RUSSIA
LEROY-SOMER DIVISION

SAUDI ARABIA
ABUNAYYAN TRADING CORPORATION

SINGAPORE
LEROY-SOMER SOUTHEAST ASIA PTE LTD

SOUTH AFRICA
LEROY-SOMER PTY LTD

SPAIN
LEROY-SOMER IBERICA S.A.

SWEDEN
LEROY-SOMER NORDEN AB

SWITZERLAND
LEROY-SOMER SA

TAIWAN
LEROY-SOMER LIAISON OFFICE

THAILAND
LEROY-SOMER THAILAND

TUNISIA
ULYSSE SPARE PARTS

TURKEY
ELEKTROMEKANIK SISTEMLER

U.A.E.
LEROY-SOMER DIVISION
EMERSON FZE

UNITED KINGDOM
LEROY-SOMER LTD

USA
LEROY-SOMER POWER AND DRIVES

VENEZUELA
LEROY-SOMER C/O EMERSON ELECTRIC CA



**LEROY
SOMER**

EMERSON
Industrial Automation

Leroy-Somer reserves the right to modify the characteristics of its products at any time in order to incorporate the latest technological developments.
The information contained in this document may therefore be changed without prior notice.

338 567 258 RCS ANGOULÊME - S.A. au capital de 62 779 000 €